

Erosion & Sediment Control Field Guide for Builders



Catchments
& Creeks

Version 3, 2013

Erosion and Sediment Control Field Guide for Builders

Version 3, January 2013

Prepared by: Grant Witheridge, Catchments & Creeks Pty Ltd

Published by: Catchments & Creeks Pty Ltd

Diagrams by: Grant Witheridge, Thomas (Jesse) Baber and Bryde Cameron of Catchments & Creeks Pty Ltd

Photos by: Catchments & Creeks Pty Ltd and Geofabrics Australia

Except as permitted under copyright laws, no part of this publication may be reproduced within another publication without the prior written permission of the publisher.

Permission, however, is granted for users to:

- store the complete document on a database, but not isolated parts of the document;
- print all or part of the document, and distribute such printed material to a third party;
- distribute the complete document in electronic form to a third party, but not isolated parts of the document.

All diagrams are supplied courtesy of Catchments & Creeks Pty Ltd and remain the ownership of Catchments & Creeks Pty Ltd. No diagram or photograph may be reproduced within another publication without the prior written permission of the Director of Catchments & Creeks Pty Ltd.

This document should be referenced as:

Witheridge 2013, *Erosion and Sediment Control Field Guide for Builders*. Catchments & Creeks Pty Ltd., Brisbane, Queensland

Key-words: ESC, erosion and sediment control, soil erosion, erosion control, sediment control, soil management, building site management.

© Catchments & Creeks Pty Ltd, 2013

Disclaimer

Significant effort has been taken to ensure that this document is representative of current (2012) best practice erosion and sediment control; however, the author cannot and does not claim that the document is without error, or that the recommendations presented within this document will not be subject to future amendment.

To be effective, erosion and sediment control measures must be investigated, planned, and designed in a manner appropriate for the given work activity and site conditions.

No warranty or guarantee, express, implied, or statutory is made as to the accuracy, reliability, suitability, or results of the methods or recommendations.

The author shall have no liability or responsibility to the user or any other person or entity with respect to any liability, loss, or damage caused, or alleged to be caused, directly or indirectly, by the adoption and use of any part of the document, including, but not limited to, any interruption of service, loss of business or anticipatory profits, or consequential damages resulting from the use of the document.

Specifically, adoption of the recommendations and procedures presented within this field guide will not guarantee:

- (i) compliance with any statutory obligations;
- (ii) compliance with specific water quality objectives; or
- (iii) avoidance of environmental harm or nuisance.

Principal reference documents:

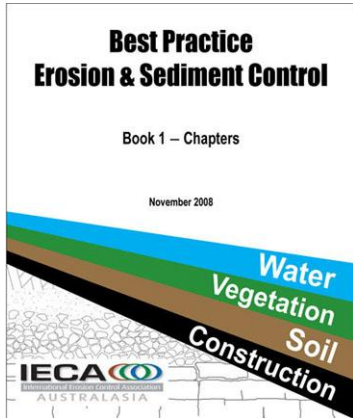

IECA (2008) – Book 1

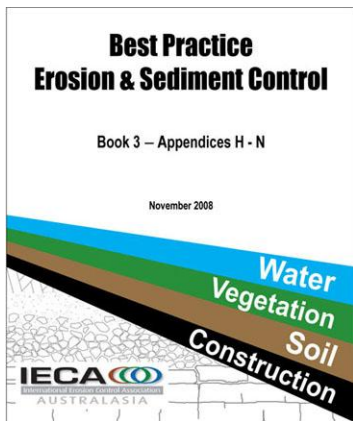

IECA (2008) – Book 3

Building Sites Part 1: General

MISCELLANEOUS TOPICS

Key Principles

1. Prepare and implement an Erosion and Sediment Control Plan (ESCP) for the site.
2. Allow for the early installation of any areas of disturbance located within the immediate work area. For example, after the completion of the initial network, it is often possible to establish a grassed buffer before works commence on the building.
3. Minimise the number of site entry points, particularly to one established rock pad.
4. Depress the erodible surface area of land to the absolute possible limit.
5. Store and promptly replace the topsoil.
6. Direct on-site stormwater runoff around the disturbance.
7. Construct roof water downpipes to the permanent drainage system immediately the roof and gutters are installed.
8. Actively control wind and rain-induced soil erosion.
9. Firmly compact and stabilise all backfilled areas/reaches.
10. Minimise the quantity of erodible material within the sediment control zone.
11. Place all long-term stockpiles of erodible material within the sediment control zone.
12. Fully enclose all stock water runs, conduits, drains, gutters, and clearing operations within an on-site area of grass or open soil.
13. Promptly regrade or otherwise stabilise all soil disturbances.
14. Maintain all erosion and sediment control measures to proper working order at all times.

Development of Erosion and Sediment Control Plans for Building Sites

The following section provides a procedure for the preparation of Erosion and Sediment Control Plans (ESCPs) for single-building building sites. This procedure has been developed as a guide only, and does not necessarily address all issues applicable to every site.

This information is not intended to replace the need for site-specific evaluation and design. It is required to ensure that the Erosion and Sediment Control Plans comply with all relevant local, State and Federal legislation, and industry codes of practice.

Suggested procedure for the development of Erosion and Sediment Control Plans for single building sites is presented below:

- Step 1 Evaluate site limitations
- Step 2 Stabilise site erodible points
- Step 3 Locate material stockpile areas
- Step 4 Control on-site stormwater
- Step 5 Control sediment runoff
- Step 6 Control erosion on disturbed areas
- Step 7 Control roof water drainage
- Step 8 Define the finalisation sequence
- Step 9 Prepare technical notes for the ESCP

Photo 1 - Suitable site limitations

Assess the site conditions and any site-specific concerns, including:

- specific vegetation that may need to be identified and/or retained from the site disturbance;
- highly erodible soils that may require additional erosion control measures;
- up-slope drainage catchments that may need to be diverted around the work site;
- any other features that may require the specific erosion control measures and/or the extensive use of bags or bins for material storage and waste management.

Photo 5 - Caution tapes used to identify non-disturbance areas and/or restricted vegetation.

IECA (2008) Book 4 Fact Sheet

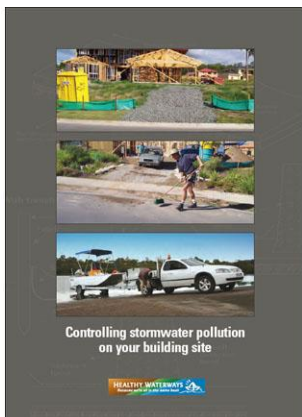

Healthy Waterways (2009)

Best Practice Erosion & Sediment Control. International Erosion Control Association, (IECA) Australasia Chapter, 2008

Contents (key chapters identified in red text):

1. Introduction
2. Principles of erosion and sediment control
3. Site planning
4. Design standards and technique selection
5. Preparation of plans
6. Site management
7. Site inspection
8. Bibliography

Book 3: Appendices

Contents:

- H. Building sites
- I. Instream works
- J. Road and rail construction
- K. Access tracks and trails
- L. Installation of services
- M. Erosion processes
- N. Glossary of terms
- X. Index (Books 1 to 3)

The full set of books may be purchased through: www.austieca.com.au

Best Practice Erosion & Sediment Control. International Erosion Control Association, (IECA) Australasia Chapter, 2008

Book 4 – Design Fact Sheets, specifically the Miscellaneous Fact Sheets:

- Building Sites Part-1 (General)
- Building Sites Part-2 (Hazard Assessment)
- Building Sites Part-3 (Site Inspection)
- Building Sites Part-4 (Standard Drawings)

These fact sheets may be down-loaded from:

www.austieca.com.au
www.catchmentsandcreeks.com.au

Controlling Stormwater Pollution on your Building Sites, 2009

Healthy Waterways, Brisbane, Queensland

Contents	Page
Purpose of field guide	5
About the author	5
Introduction	5
Impacts of soil erosion and sediment run-off	6
Benefits of effective erosion and sediment	7
Types of soil erosion	8
Key management practices	9
Site Assessment	
Site assessment and planning	11
The provision of expert advice	12
Assessment of soil conditions	13
Testing for dispersive and slaking soils	14
Problems caused by dispersive and slaking soils	15
Management of dispersive soils on building sites	16
Assessment of drainage requirements during the building phase	17
Assessment of permanent stormwater requirements	18
Preparation of Erosion & Sediment Control Plans	19
Example Erosion & Sediment Control Plans	20
Example technical notes	21
Erosion & Sediment Control during the Building Phase	
Critical components of building site erosion and sediment control	23
Work site practices	24
Material stockpiles	26
Drainage control measures	27
Stabilisation of high-velocity drains	28
Control of roof water	29
Stabilised site entry/exit points	30
Sediment control measures	31
Sediment fence	32
Kerb inlet sediment traps	34
Grated inlet sediment traps	36
Service trenches	38
Erosion control measures	39
Maintenance of Control Measures	
Site Maintenance	41
Site check list	43
Glossary of terms	44

Purpose of field guide

This field guide has been prepared specifically to:

- provide builders with general guidelines on the management of building sites with respect to soil erosion and sediment run-off;
- provide building contractors with general guidelines on the selection of appropriate drainage, erosion, and sediment control measures for small, single-dwelling, building sites.

The field guide has **not** been prepared for the purpose of being a site's primary guide to erosion and sediment control. As such, the recommendations provided within this field guide should **not** be used to overrule advice obtained from suitably trained experts, or the recommendations and/or requirements of locally adopted ESC guidelines/manuals.

The field guide has been prepared primarily for small, single-dwelling building sites. As such, it is not necessarily applicable to multiple-dwelling building sites or civil construction sites, but all building and construction sites do share many common principles of stormwater management, and erosion and sediment control.

About the author

Grant Witheridge is a civil engineer with both Bachelor and Masters degrees from the University of NSW (UNSW). He has some 30 years experience in the fields of hydraulics, creek engineering and erosion & sediment control, during which time he has worked for a variety of Federal, state, local government and private organisations.

Grant is the principal author of the IECA (2008) Best Practice Erosion & Sediment Control documents, and in 2010 was the recipient of IECA (International) *Sustained Contributor Award* for services to the erosion and sediment control industry.

Introduction

The three cornerstones of the 'erosion and sediment control industry' are *drainage control*, *erosion control*, and *sediment control*. The functions of building site drainage, erosion, and sediment controls are presented below.

- Drainage control measures aim to prevent or reduce soil erosion caused by concentrated flows (including the management of rill and gully erosion), and to appropriately manage the movement of 'clean' and 'dirty' water through the work site. Drainage control measures are often temporary measures that are operational only during the building phase. These measures should not be confused with the permanent stormwater management requirements of residential properties.
- Erosion control measures aim to prevent or reduce soil erosion caused by raindrop impact and sheet flow (i.e. the control of splash and sheet erosion). These measures can be either temporary or permanent.
- Sediment control measures aim to trap and retain sediment displaced by up-slope erosion processes. These are mostly temporary measures that are operational only during the building phase.

It is noted that on most work sites, best practice sediment control measures cannot, on their own, provide adequate protection of downstream environments. Therefore, appropriate drainage and erosion control measures must also be applied, wherever practical, especially when working within clayey soils.

One of the most notable features of the erosion and sediment control industry is that there is almost always an exception to every rule and guideline. The fact that a control measure is observed to work well on one site or region does not mean that it will work well on all sites.

Small building sites represent a unique set of site conditions within the erosion and sediment control industry. These sites are usually too small to incorporate high standard sediment control measures such as *Sediment Basins*, and it is often impractical to incorporate effective erosion control measures until the building activities are near completion.

What is considered 'reasonable and practicable' on a construction site may not be considered 'reasonable and practicable' on a typical building site. 'Common sense' is often a good test, and this should never be lost amongst the numerous rules and regulations.

Impacts of soil erosion and sediment run-off



Dust generated on a construction site

Dust problems

- It is important to remember that soil erosion can be generated by wind, rain and flowing water.
- Dust generation is more commonly associated with civil construction sites than building sites.
- Dust generated from building sites; however, can become a nuisance to neighbouring properties, including damage to recently washed cloths and fabrics.



Sedimentation of drainage pipes

Sedimentation within stormwater drains

- Sediment washed from building sites can settle within stormwater drains causing:
 - increased property flooding
 - increased flooding on roadways
 - increased council maintenance costs
 - increased risk of mosquito problems
- Sediment can also settle on roadways causing road safety issues.



Deposition of sand within a waterway

Deposition of coarse sediments

- The deposition of coarse sediment in minor waterways, such as creeks, can:
 - increase the risk of property flooding;
 - cause bank erosion and channel instabilities
 - cause the loss of essential aquatic habitats
 - increase the weed infestation of creeks
 - increase maintenance costs for stormwater asset owners such as local councils

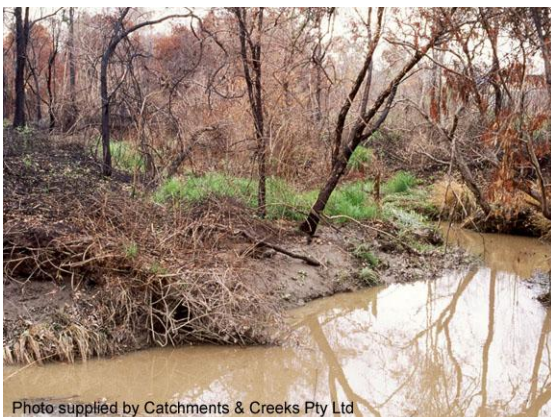

Turbid water within an urban waterway

Release of fine sediments and turbidity

- The release of fine sediments and turbid water into waterways can:
 - adversely affect the health and biodiversity of aquatic life
 - adversely affect recreational and commercial fishing
 - increase the concentration of nutrients and metals within these waters
 - increase the risk of algal blooms
 - increase the risk and cost of water treatment works associated with both farm dam and town water supplies

Benefits of effective erosion and sediment



Muddy site access track

Improved wet weather site conditions

- Having effective site drainage during the building phase can significantly reduce site wetness during periods of wet weather.
- Diverting 'clean' water around soil disturbances can also reduce the generation of muddy ground.
- Experience has shown that overall building times are reduced when roof water is directed to a stormwater system rather than just discharging onto ground.



Landscaping of finished works

Improved landscaping

- Walking or driving (e.g. bobcats) over saturated ground not only generates muddy conditions (above photo), but can also cause long-term soil drainage problems.
- If not corrected, such soil problems can lead to long-term health and growth problems for future plants.
- Damaged soil conditions often also means these areas will become boggy even after only just small amounts of rainfall.



Sediment deposition on roadway

Reduced clean-up costs

- Well managed building sites can become fully operational much faster after wet weather compared to poorly managed sites.
- Effective sediment control measures can reduce the need to clean mud and sand from roadways.



Public information sign

A better public image

- Clean well-managed building sites present a better public image for the building industry.
- Remember; neighbourhood disputes that commence during the building phase can result in long-term problems for the homeowners that inherit the site once you have left.

Types of soil erosion

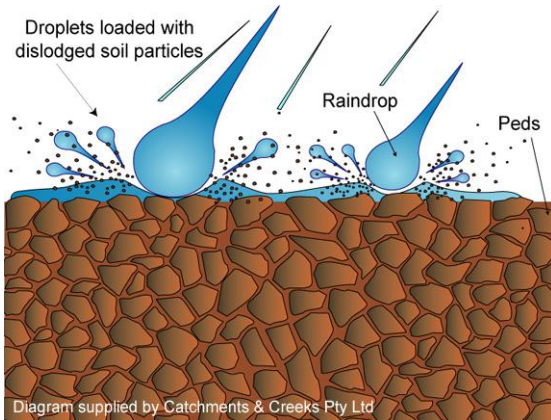

Raindrop impact erosion



Land subject to sheet erosion



Rill erosion adjacent a building pad



Erosion of a dispersive soil

Raindrop impact erosion

- Raindrops can exert significant force upon impact with the ground.
- The resulting soil erosion is often difficult to detect and consequently is often ignored.
- Raindrop impact erosion is a major cause of the release of fine, clay-sized particles from building sites.
- Raindrop impact onto clayey soils is one of the main reasons why stormwater runoff develops a deep brown colour.

Sheet erosion

- Sheet erosion is the removal of an even layer of surface soil through the actions of raindrop impact and stormwater runoff.
- Sheet erosion is likely to occur if stormwater run-off flows over open soil at a speed greater than walking pace.
- After a distance of around 10 m, sheet erosion is likely to change into 'rill erosion'.
- It is noted that the loss of just 1 cm of soil from a 500 m² allotment represents the displacement of 5 m³ of soil.

Rill erosion

- A 'rill' is an individual eroded channel in the soil that is less than 300 mm deep.
- Rill erosion is typically caused by high velocity concentrated flows (i.e. water flowing at a brisk walking pace or faster).
- Rilling can also result from soil dispersion (see below).
- Along with flow velocity, soil compaction and soil chemistry can also influence the degree of rilling.

Chemical erosion

- Soil chemistry can have a significant influence over the severity and extent of soil erosion.
- If a soil is 'dispersive' then it is likely to be highly unstable when wet, resulting in severe, deep rilling (or 'fluting' shown left), tunnel erosion and/or gully erosion.
- As a general guide, if the soil erosion is significantly deeper than its width, then soil chemistry is likely to be a contributing factor to the soil erosion.

Key management practices



Building site



Sediment fence



Mulching of disturbed site access pathway



Fully turfed and stabilised backyard

Key ESC management practices

Small building sites present a unique set of site conditions for the erosion and sediment control (ESC) industry.

However, the key principles of erosion and sediment control do not vary from small building site to large civil construction sites.

The differences mainly appear in the priorities given to each of the key principles in respect to on-site drainage, erosion and sediment control.

When applied to small building sites, the key management practices can be summarised as:

1. Apply sensible site planning that respects the local topography.
2. Develop formal Erosion and Sediment Control Plans for high-risk sites.
3. Obtain all required approvals before soil disturbances or building works commence.
4. Divert up-slope stormwater run-off around soil disturbances.
5. Stabilise site entry/exit points.
6. Ensure that the smallest area of land is disturbed for the shortest period of time.
7. Save and promptly replace the topsoil.
8. Install appropriate sediment controls along the lower edge of the soil disturbance or work site.
9. Place all long-term stockpiles of erodible material within the *sediment control zone*.
10. Connect roof water downpipes to the permanent stormwater drainage system immediately the roof and guttering are installed.
11. Actively control wind- and rain-induced soil erosion.
12. Fully contain all wash-water from concreting, ceramic cutting, and equipment cleaning activities within an on-site area of grass or porous soil.
13. Continually monitor and maintain all control measures.
14. Firmly compact and stabilise all backfilled service trenches.
15. Promptly revegetate or otherwise stabilise disturbed areas once works are finished within each work area.

Site Assessment

Site assessment and planning



Photo supplied by Catchments & Creeks Pty Ltd

Site meeting

Appropriate building practices

- The builder–client relationship can exist in many different forms.
- Some clients are open to advice; some clients have fixed ideas that are unlikely to change.
- Wherever practical, builders should assist home-owners in choosing building layouts and building practices that are appropriate for the site conditions.



Photo supplied by Catchments & Creeks Pty Ltd

Building site subject to severe wet weather

Extent and timing of soil disturbances

- Soil disturbing activities on steep sites should be scheduled for the drier periods of the year, especially in tropical regions.
- During the wet season, concentrate on those work activities that do not require any soil disturbances.
- Major earthworks should be delayed until just prior to the commencement of building activities.
- Disturbances to the road verge should be kept to a minimum.



Photo supplied by Catchments & Creeks Pty Ltd

Pole home being built on a steep site

Building on steep slopes

- It is better to modify the building to suit the land, than to modify the land to suit the building.
- On steep sites, avoid the use of ‘slab-on-ground’ construction techniques as this can greatly increase the erosion hazard, and potentially result in ongoing erosion problems.
- ‘Slab-on-ground’ construction should ideally be limited to land slopes less than 10%, and certainly not on slopes exceeding 20%.



Photo supplied by Catchments & Creeks Pty Ltd

Poor activities occurring on the footpath

Work space limitations

- It is important to ensure that there is sufficient space to locate all building materials and stockpiles on the property.
- Building the biggest home on the smallest allotment may be all the rage, but it should not come at the cost of long-term environmental harm.
- Space-limited building sites may require site-specific sediment control measures and/or the extensive use of mini-skips for material storage and waste removal.

The provision of expert advice

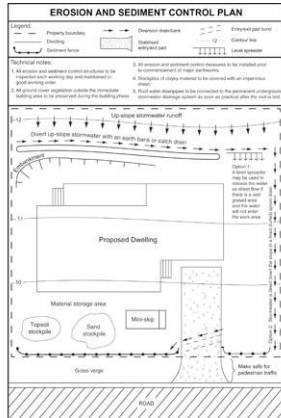

Diagram supplied by Catchments & Creeks Pty Ltd

Erosion & Sediment Control Plan

Erosion & sediment control specialists

- Erosion & sediment control plans often need to be prepared as part of the building application.
- On complex or high-risk building sites it may be advisable to seek the advice of a specialist erosion control consultant with CPESC qualifications.
- A Certified Professional in Erosion and Sediment Control (CPESC) is a consultant specifically trained in the practices of erosion and sediment control.



Photo supplied by Catchments & Creeks Pty Ltd

Drainage problems on a building site

Property drainage

- Investigations into potential overland flow problems, including the management of significant quantities of stormwater run-off passing through a property, normally requires input from an engineer who specialises in stormwater management.
- If drainage problems are not major, then your plumber may be able to advise you on a suitable drainage plan.



Photo supplied by Catchments & Creeks Pty Ltd

Failed rock retaining wall

Retaining walls

- Retaining walls can present many problems to builders and home-owners.
- Most of these problems relate to either drainage or land stability issues.
- Drainage issues should be investigated by a stormwater engineer or geotechnical consultant.
- Land stability issues should be investigated by a geotechnical consultant and/or structural engineer.



Photo supplied by Catchments & Creeks Pty Ltd

Gully erosion up-slope of a new home

Soil investigations

- If the soils are chemically unstable, then minor earthworks on a steep site can initiate major gully erosion problems.
- If your building proposal involves cutting into the side of a steep slope to form the building foundations, then a geotechnical investigation is recommended.
- If soil tests identify dispersive, sodic or slaking soils, then advice from a 'soil scientist' may be required (see over page).

Assessment of soil conditions



Severe rill erosion



Sandy soil region



Clayey soil building pad



Dispersive soil

Soil condition

- Structurally unstable soils can experience severe erosion problems once vegetation is removed.
- If soils are imported onto the site, then efforts should be taken to ensure the soils provide the required stability and erosion resistance when wet.
- Dispersive, sodic or slaking soils (discussed below) can be very unstable when wet.
- Sandy soils can be unstable when wet or dry.

Sandy soils

- Sandy soils, such as those that commonly occur along coastal regions, can be highly erodible once vegetation is removed.
- Heavy storms during the building phase can cause significant quantities of sediment (sand) to be washed from the site if appropriate measures are not taken.
- These sites are best managed with the use of a properly installed **sediment fence**.
- Steep, sandy sites require expert advice.

Clayey soils

- Clayey soils can be either highly erosion resistant or highly erodible.
- As a general guide, the lower the sodium content and the higher the organic content of the soil, the greater the erosion resistance.
- When working in clayey soils, priority should be given to minimising soil erosion wherever practical – don't just rely on sediment control measures.

Dispersive soils

- Soil chemistry typically affects soil erosion through a process called 'dispersion', which most commonly results from high levels of sodium within the soil.
- Dispersive soils are often recognised by the occurrence of deep, narrow rilling. Often the rills are spaced only a few centimetres apart.
- Alternatively, if the surface of soil looks like the surface of a white ant nest, then it is again possible that the soil is dispersive.

Testing for dispersive and slaking soils

ORGANIC MATTER		
Organic Matter	%	1.7
SALINITY		
Electrical Conductivity	dS/m	0.09
Chloride	mg/kg	28
Sodium	mg/kg	26
EXCHANGEABLE CATIONS		
Exchangeable Sodium	meq/100g	0.11
Exchangeable Potassium	meq/100g	0.37
Exchangeable Calcium	meq/100g	0.40
Exchangeable Magnesium	meq/100g	0.30
Exchangeable Aluminium	meq/100g	Not Applicable
Exchangeable Sodium Percent	%	9.6
Exchangeable Potassium Percent	%	31.6
Exchangeable Calcium Percent	%	33.4
Exchangeable Magnesium Percent	%	25.4
Exchangeable Aluminium Percent	%	Not Applicable
Cation Exchange	meq/100g	1.18
Calcium/Magnesium Ratio		1.32

Soil analysis



Photo supplied by Catchments & Creeks Pty Ltd

Dispersive soil



Photo supplied by Catchments & Creeks Pty Ltd

Non dispersive, non slaking soil



Photo supplied by Catchments & Creeks Pty Ltd

Slaking soil

Exchangeable sodium percentage

- In high-risk areas, the soils should be scientifically tested prior to designing foundations or retaining walls.
- Concerns should be raised if the soil test indicate either:
 - Exchangeable sodium percent > 6%
 - Emerson aggregate classes 1 to 5. Note; classes 3(2), 3(1) and 5 have a slight risk of dispersive problems.

Aggregate immersion test

- The **Aggregate Immersion Test** can be used as an indicator of dispersive soils.
- The test involves filling a dish with distilled water to a depth sufficient to cover the soil samples. Several dry, hard clumps of soil are then gently placed in the water. The water is then observed for colour changes (**after** all the air has escaped).
- If the water discolours both horizontally & vertically around the samples, then the soil may be dispersive. Highly dispersive soils will collapse in less than 10 minutes.

Non-dispersive soil

- If the water remains clear and the boundary of the soil clumps remains clearly defined, then the soil is likely to be non-dispersive.
- If the soil clumps are loose or otherwise heavily disturbed, then the soil clumps will likely separate into smaller pieces when first placed into the water. This does not indicate that the soil is dispersive.
- Air escaping from the soil can also cause the clumps to fall apart. This does not indicate that the soil is dispersive.

Slaking soils

- Slaking soils are soils that readily collapse in water, but do not necessarily cloud the water.
- If the water remains clear, and the clumps completely collapse and **spread horizontally**, then the soil could be a slaking soil.
- Slaking soils commonly occur within regions containing granite rock. These soils can also be highly erodible.

Problems caused by dispersive and slaking soils



Photo supplied by Catchments & Creeks Pty Ltd

Deep rill erosion

Deep rilling

- If drainage channels are cut into dispersive soils, then these drains can quickly erode.
- The erosion usually takes the form of a deep 'rill' with near-vertical sides.
- If an open drain must be cut into such soils, first strip and save the existing topsoil (if any), cut the drain, then use the topsoil, or any other non-dispersive soil, to place a minimum 200 mm (min) thick cover over the dispersive soil, before revegetating the drain.



Photo supplied by Catchments & Creeks Pty Ltd

Tunnel erosion under concrete drain

Tunnel erosion

- Dispersive soils are highly susceptible to tunnel erosion.
- Such tunnel erosion can appear in earth embankments and farm dams.
- Sealing dispersive soils with concrete can result in tunnel erosion forming under the concrete (left).
- Similar tunnel erosion can also form under loose rock and rock mattress linings.



Photo supplied by Catchments & Creeks Pty Ltd

Failed gabion overflow spillway

Failure of retaining walls

- Many types of retaining walls and overflow spillways rely on the stability of the underlying soil for their overall structural stability.
- If these structures are constructed on a dispersive soil, the risk of structural failure can be increased significantly.
- The failure of a retaining wall within a small residential allotment can result in significant financial repair costs due to the space limitations often associated with such properties.



Photo supplied by Catchments & Creeks Pty Ltd

Gully erosion in a slaking soil

Land slips and gully erosion

- Dispersive and slaking soils are highly susceptible to gully erosion and land slips.
- 'Cut-and-fill' earthworks should be avoided, or at least heavily supervised, if the property contains dispersive soils.
- This means 'slab-on-ground' construction processes may not be suitable on land with a gradient steeper than 5%.

Management of dispersive soils on building sites



Photo supplied by Catchments & Creeks Pty Ltd

'Cut-and-fill' construction

Avoid cutting into a dispersive soil

- The extent and severity of earthworks should be minimised when working on dispersive soils.
- If it is necessary to cut into a dispersive soil, then seek expert advice from a soil scientist or geotechnical engineer on how to seal and protect the dispersive soils.
- 'Slab-on-ground' construction processes should be avoided on land with a gradient steeper than 5% unless appropriate expert advice has been obtained.



Photo supplied by Catchments & Creeks Pty Ltd

Erosion of an open soil drain

Seal and stabilise all drainage channels

- Do **not** form open soil drains within a dispersive soil.
- In dispersive soil areas, all excavated drains should be sealed with a minimum 200 mm layer of non-dispersive soil and then stabilised.
- Do **not** placed filter cloth, concrete, rock, gabions, or rock mattresses directly on a dispersive soil without first covering the soil with a suitable layer of non-dispersive soil.

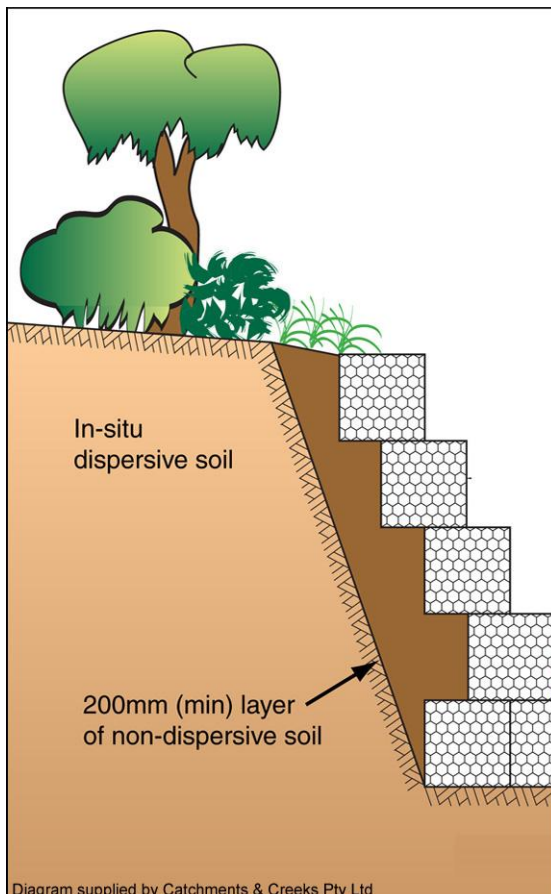

Diagram supplied by Catchments & Creeks Pty Ltd

Retaining wall adjacent a dispersive soil

Retaining walls

- In most circumstances, the best treatment for dispersive soils is to ensure the soil is buried under a layer of non-dispersive soil before the final surface treatment.
- When a retaining wall is constructed adjacent a dispersive soil, then **prior** to placement of filter cloth or a drainage layer, the exposed soil **must** first be covered with a layer of non-dispersive soil, typically minimum 200 mm thickness, but preferably 300 mm.
- Do **not** placed filter cloth, concrete, rock, gabions, or rock mattresses directly on a dispersive soil without first covering the soil with a suitable layer of non-dispersive soil.
- A dispersive soil should **not** be directly seeded or covered with erosion control fabric without first sealing the soil with a layer of non-dispersive soil.

Assessment of drainage requirements during the building phase

- Some building sites may require temporary drainage control measures to divert stormwater run-off around soil disturbances and active work areas.
- As a guide, if the up-slope drainage area exceeds 1500 m², and the monthly rainfall is expected to exceed 45 mm, then all reasonable and practicable measures should be taken to divert stormwater run-off around any soil disturbances.
- Each work site and climatic region is different and thus the need for temporary drainage control measures must be assessed on a site-by-site basis (ask your local council).
- In all cases, it is important to ensure that stormwater is not unlawfully diverted or released into neighbouring properties, or allowed to cause erosion at points of discharge.

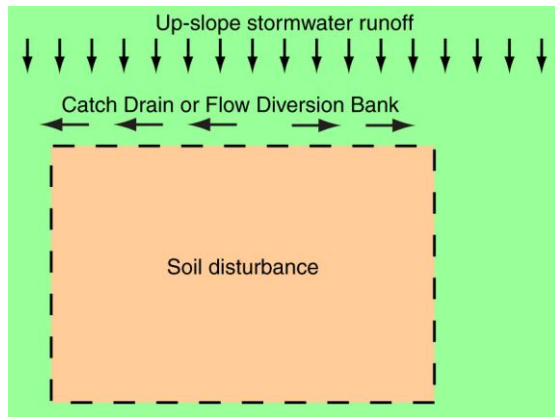

Diversion of flows across the slope

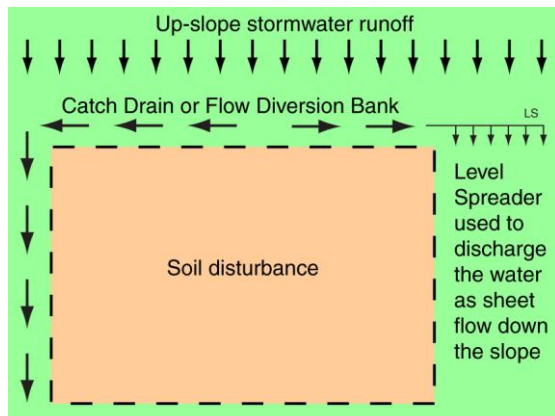

Flow diversion down the slope

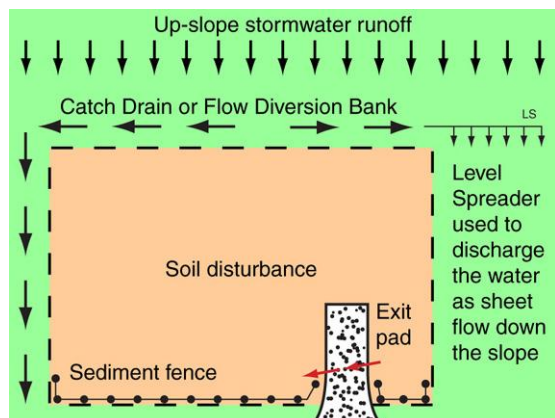

Diversion of driveway run-off

Tasks:

- **Firstly**, assess the benefits and practicality of diverting up-slope run-off around any given soil disturbance.
- Temporary drainage options include **Flow Diversion Banks** (possibly formed from the stripped topsoil), and excavated **Catch Drains**.
- If the subsoils are known to be **dispersive** or highly erodible, then avoid cutting drains into the soil. Instead, use **Flow Diversion Banks** to redirect water across the slope.
- **Secondly**, choose an appropriate gradient and channel lining for each drain. Low gradient drains may be left with an open soil surface.
- If flow velocities are expected to be high, then either control the water velocity with the use of **Check Dams**, or select an appropriate channel lining.
- **Thirdly**, consider how best to move stormwater down any steep slopes.
- Drainage options include **Slope Drains** for minor flows, or suitably lined drainage **Chutes**. Alternatively, a **Level Spreader** can be used on large allotments to release the water as 'sheet' flow down a well-grassed slope.
- **Fourthly**, ensure that any stormwater run-off flowing towards the street or driveway is diverted towards an adjacent **Sediment Fence**.
- If the property has a long, unsealed driveway, then stormwater run-off may need to be diverted off the driveway at regular intervals with the use of raised earth cross-drains (speed bumps).
- **Finally**, ensure that stormwater is not unlawfully diverted or released into neighbouring properties, or allowed to cause erosion at points of discharge.

Assessment of permanent stormwater requirements



Photo supplied by Catchments & Creeks Pty Ltd

Roof water drainage during a major storm

Roof water drainage

- The typical stormwater drainage layout for a residential property consists of four main components:
 - Roof water drainage
 - Subsoil drainage system
 - Minor storm drainage system
 - Major storm drainage system
- Roof water drainage systems normally convey only the minor storms.
- Roof water drainage systems will generally overtop during major storms.



Photo supplied by Catchments & Creeks Pty Ltd

Subsoil drainage

Subsoil drainage system

- A subsoil drainage system is generally required if:
 - the property contains a retaining wall
 - a building is recessed into the earth, or earth is placed up against a building
- Special care must be taken when designing subsoil drainage systems if the soils are dispersive.



Photo supplied by Catchments & Creeks Pty Ltd

Grated stormwater inlet

Minor storm drainage system

- Stormwater run-off from minor storms is normally conveyed through urban properties within sub-surface pipes.
- Grated stormwater inlets can be used to collect minor flows and feed the run-off into a piped drainage system.
- These grated inlets can be subject to significant debris blockage during major storms.



Photo supplied by Catchments & Creeks Pty Ltd

Overland flow during a major storm

Major storm drainage system

- The run-off from major storms usually needs to be conveyed through properties as overland flow.
- Rarely can an underground drainage system carry the full run-off expected from a major storm.
- The design of the major storm drainage system usually requires experience and a good eye for detail. On complex sites, seek advice from a stormwater engineer.

Preparation of Erosion & Sediment Control Plans

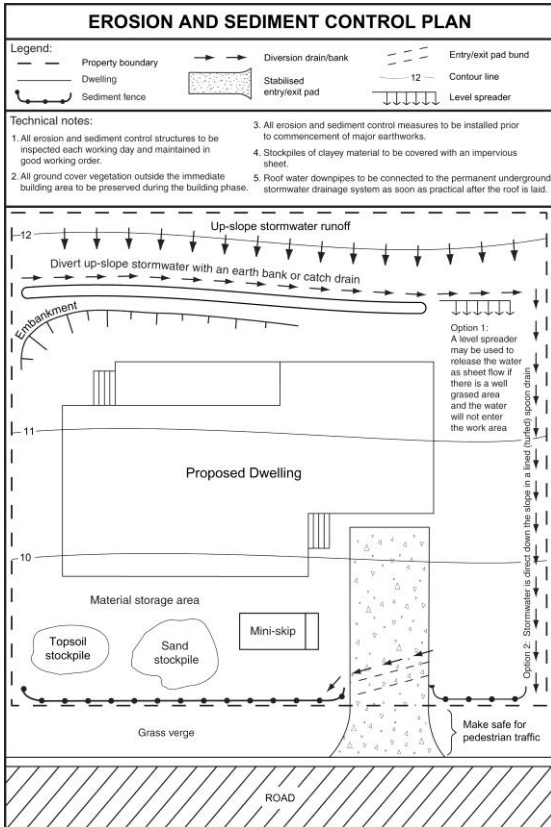

Erosion & Sediment Control Plans (ESCP)

- For high-risk sites, an Erosion and Sediment Control Plan (ESCP) should be prepared prior to any site disturbance.
- The plan must be appropriate for the site topography and climatic conditions.
- These plans should detail the proposed means of controlling stormwater drainage, soil erosion, and sediment run-off during the building phase.
- The level of detail supplied in the ESCP must be commensurate with the complexity of the building works.
- Technical notes can be included on the plan to identify critical actions and control measures required on the site.

Example plans

The following diagrams show examples of the general layout of temporary drainage and sediment control measures on various building sites.

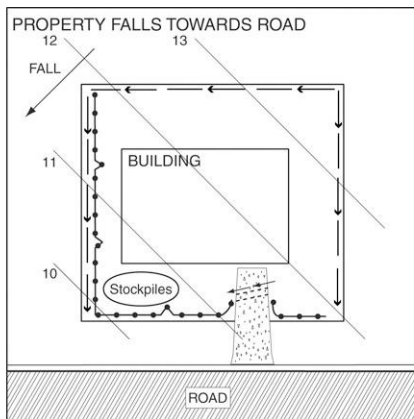

Diagram supplied by Catchments & Creeks Pty Ltd

Property that falls diagonally towards the road

- The sediment fence may require occasional 'returns' (zigzags) in order to prevent stormwater simply flowing down the fence to the lowest corner of the property.
- Fence 'returns' are normally installed at a maximum spacing of 10 m.
- These 'returns' should extend at least 1m up the slope.

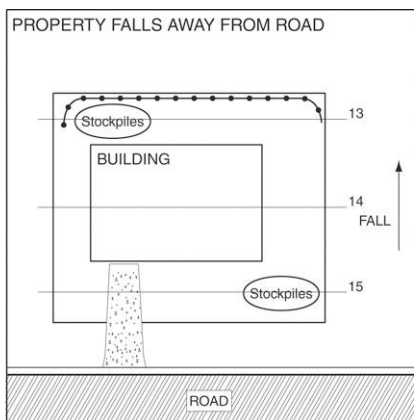

Diagram supplied by Catchments & Creeks Pty Ltd

Property that falls away from the road

- The entry/exit pad does not require a raised flow diversion bund because sediment-laden run-off from the entry/exit pad will not flow towards the road.
- Placement of a sediment fence or safety fence along the front of the property can help to restrict traffic movement to the entry/exit pad.
- The sediment fence may be fixed to the back fence (if available), but must still be suitably buried (anchored).
- Stormwater run-off from stockpiles must drain to the sediment fence or other suitable sediment trap.

Example Erosion & Sediment Control Plans

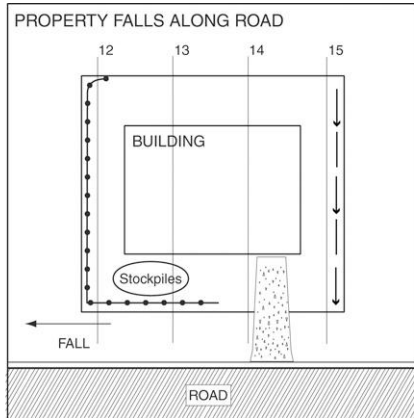

Diagram supplied by Catchments & Creeks Pty Ltd

Property that falls parallel to the road

- If property fencing already exists, then a sediment fence (suitably anchored) may be fixed to the fence for support.
- Extending the sediment fence along the front of the property can help to control vehicular movements onto the site.
- The entry/exit pad may or may not require a raised flow diversion bund to prevent sediment-laden water flowing off the rock pad onto the road.

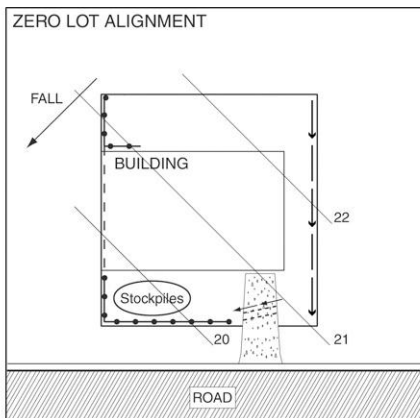

Diagram supplied by Catchments & Creeks Pty Ltd

Property with a building face along one boundary line (zero lot alignment)

- Initially a sediment fence should be located along the full length of the lower property boundary.
- Sections of this sediment fence may need to be removed to allow foundations and building works to be completed, but it must remain in place and in proper working order for as long a practical.

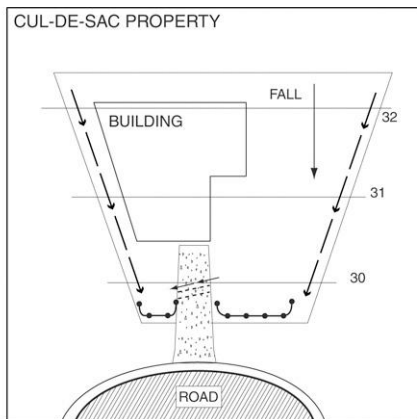

Diagram supplied by Catchments & Creeks Pty Ltd

Property that falls towards the road

- Catch drains located along the side of the property are only required if it is necessary to either, permanently direct stormwater away from adjacent properties, or to temporarily divert sediment-laden water to a sediment fence.
- If the catch drain carries only 'clean' stormwater run-off, then the run-off should be directed **around** the sediment fence as shown on the right-hand-side of the diagram.

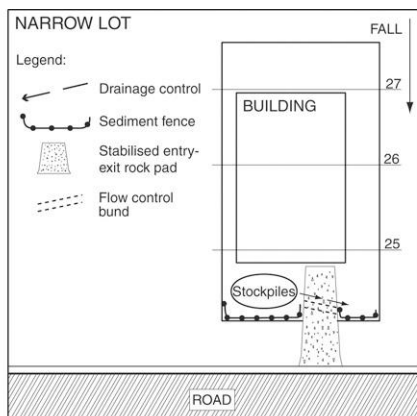

Diagram supplied by Catchments & Creeks Pty Ltd

Narrow lots

- In most cases drainage and sediment controls on narrow lots should be as per larger building sites.
- The sediment fence may need to be located across the full width of the lower property boundary.
- In such cases, the fence may be lowered during working works to allow site access, but must be raised at the end of each working day and while rain is occurring.

Example technical notes

The use of technical notes on an Erosion & Sediment Control Plan is a convenient way to identify and highlight critical issues or actions the builder must consider when working the building site. Erosion control measures are often best identified through the use of technical notes.

The following is a list of example technical notes.

- All sediment fences are to be installed prior to commencement of earthworks if rain is possible while earthworks are occurring.
- Prior to commencing excavations, topsoil must be stripped from the designated area and stockpiled on site for later use.
- Immediately following the completion of bulk earthworks, all disturbed areas outside the footprint of the base slab (if a base slab is used, otherwise all disturbed areas) to be mulched (minimum 50 mm) or otherwise stabilised against soil erosion.
- Designated earth batters are to be stabilised, as directed on the plans, immediately after bulk earthworks have been completed on the site.
- Appropriate building waste receptors must be located on the site and suitably maintained during the building phase.
- All ground-cover vegetation outside the immediate building area shall be preserved during the building phase.
- Damage to the road reserve (i.e. footpath) vegetation is to be minimised and repaired as soon as practicable at the builder's expense.
- No materials are to be stockpiled outside the property boundaries beyond the end of a working day.
- Soil and sand stockpiles are to be covered if strong winds are forecast that could displace the material from the site.
- Stockpiles of earth are to be covered with an impervious cover if rain is forecast.
- The site's underground stormwater drainage system is to be installed and operational prior to the roof being laid.
- Roof water downpipes (temporary or permanent) are to be connected to the stormwater drainage system immediately after the roof and guttering are laid.
- All temporary drainage and sediment control measures are to remain functional during the building phase.
- All erosion and sediment control structures are to be inspected each working day and maintained in proper working order at all times.
- Sediment is to be removed from up-slope of each sediment trap (e.g. sediment fence) immediately after rainfall if the depth of sediment exceeds 200 mm.
- Excessive sediment deposition on the rock entry/exit pad is to be removed.
- Additional rock shall be applied to the rock entry/exit pad as necessary to maintain its functionality.
- All sediment deposited off the site as a result of work-related activities is to be collected and disposed of in a manner that will prevent any safety or erosion hazard.
- Brick, tile and masonry cutting must be carried out on a pervious surface, such as grass, or open soil, or in such a manner that all sediment-laden run-off is prevented from discharging into a gutter, drain, or water body.
- Washing/flushing of sealed roadways must only occur where sweeping has failed to remove sufficient sediment and there is a compelling need to remove the remaining sediment (e.g. for safety reasons). In such circumstances, all reasonable and practicable sediment control measures must be used to prevent, or at least minimise, the release of sediment into receiving waters. Only those measures that will not cause safety and property flooding issues shall be employed. Sediment removed from roadways must be disposed of in a lawful manner that does not cause ongoing soil erosion or environmental harm.

Erosion & Sediment Control during the Building Phase

Critical components of building site erosion and sediment control

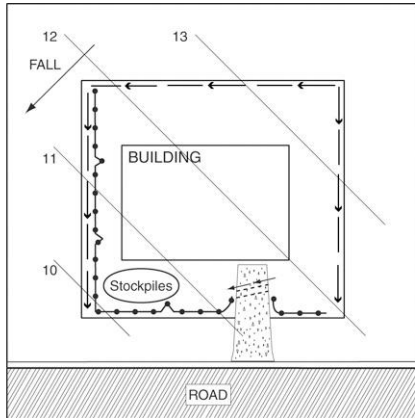

Erosion & Sediment Control Plan

Diagram supplied by Catchments & Creeks Pty Ltd

Site assessment

- An effective *Erosion & Sediment Control Plan* (ESCP) can only be developed if the site conditions have been properly assessed (refer to pages 11 to 21).
- The primary objective of the on-site erosion and sediment control practices is to ensure all reasonable and practicable measures are taken to minimise short and long-term soil erosion and the adverse effects of sediment run-off.
- What is considered 'reasonable and practicable' will vary from region to region.



Photo supplied by Catchments & Creeks Pty Ltd

Catch drain formed up-slope of work site

Drainage control (pages 27 to 29)

- *Drainage control* focuses on those temporary drainage measures required on a work site prior to installation of the permanent drainage system.
- The primary objectives of *drainage control* are to:
 - minimise soil erosion caused by concentrated flows; and
 - minimise the generation of 'mud' during periods of wet weather.



Photo supplied by Catchments & Creeks Pty Ltd

Sediment control measures

Sediment control (pages 30 to 38)

- *Sediment control measures* focus on minimising sediment run-off from a work site.
- Most sediment control measures are only effective at trapping coarse sediment particles such as coarse silts and sands.
- The soil particles that cause water to turn brown (turbid water) are generally the finer-grained particles such as fine silts and clays. These particles are best managed through effective *erosion control practices*.



Photo supplied by Catchments & Creeks Pty Ltd

Turfing finished soil profile

Erosion control (page 39)

- *Erosion control measures* focus on minimising soil erosion caused by raindrop impact and sheet flow (i.e. the control of splash and sheet erosion).
- The primary objectives here are to:
 - minimise the duration disturbed soils are exposed to strong winds and rainfall; and
 - stabilise disturbed soils with temporary or permanent erosion control measures as soon as practical after earthworks are finished in any given area.

Work site practices



Mini skip

Waste management

- Adequate waste collection bins must be provided on-site and maintained such that 'potential' and 'actual' environmental harm resulting from such material waste are minimised.
- Many waste products, such as earth and cement, can become part of the sediment run-off if not appropriately stored in waste receptors.



Secured storage containers

Equipment storage

- It is uncommon for shipping containers to be used on residential building sites to secure building materials; however the practice is common on larger commercial building sites.
- The use of storage containers can help to reduce site litter and the risk of chemical spills, both of which can add to the overall pollution hazard.



Topsoil stockpiled on roadway

Delivery of building materials

- In most instances it is unacceptable for deliveries of sand and soil to be stockpiled, even temporarily, on roadways.
- If such practices are totally unavoidable, then a heavy-duty tarpaulin should first be placed over the road surface to help minimise the quantity of material left on the roadway after the materials are moved on-site.
- Material stockpiles must not remain within the road reserve beyond the end of the working day.



Soil swept from roadway

Cleaning materials from roadways

- Any pollutants, including clay, silt, sand, gravel, soil, mud, cement and ceramic waste, deposited on a roadway either as a result of soil erosion, building activities or material deliveries, must first be collected and removed by sweeping.
- The washing of sealed roadways should only occur in circumstances where sweeping has failed to remove sufficient deposited material and the remaining material represents a safety risk.

Work site practices



Photo supplied by Catchments & Creeks Pty Ltd

Building activities occurring on footpath



Photo supplied by Catchments & Creeks Pty Ltd

Cement wash-off from concreting works



Photo supplied by Catchments & Creeks Pty Ltd

Cleaning equipment over grass area



Photo supplied by Catchments & Creeks Pty Ltd

Cleaning of concrete truck

Use of the road verge

- Building activities, including material storage, should not occur on the footpath or road verge if an alternative on-site location is available.
- All works within road reserves can only occur at the discretion of the road owner (usually the council).

Controlling cement wash-off

- Brick, tile and masonry cutting must not occur outside the property.
- Cement wash-off is highly alkaline and, if allowed to wash down stormwater drains, can kill aquatic life within receiving waters.

Cleaning of equipment

- The washing of tools and painting equipment should be carried out within the property and over a porous grassed surface or open soil.
- Paint brushes should **never** be washed within a household basin (connected to the sewer) or over a stormwater grate.

Disposal of concrete waste

- The solid or liquid waste from concrete trucks and concreting equipment should be fully contained within the work site.
- If large volumes of concrete waste are expected, then a bunded earth disposal area should be formed on the site.
- Concrete spilt onto roadways **must not** be washed into a stormwater drain. Instead, scrap or sweep the bulk of the material from the road surface. Where necessary, the remaining material may be washed onto a grassed verge (if possible).

Work site practices



Cutting materials over grass surface

Control of ceramic & concrete waste

- Brick, tile and masonry cutting should be carried out on a permeable surface, such as grass or open soil, or in such a manner that all sediment-laden run-off is prevented from discharging into a gutter, drain, or water body.
- A sand berm (bricks sand) can be formed down-slope of masonry activities to filter sediment-laden wash water before it is allowed to discharge from the property.



Silt socks placed in kerb

Placement of down-slope sediment traps

- A series of sediment filter socks should be placed within the drain or road kerb down-slope of the work activities.
- Unfortunately, these sediment traps cannot treat the primary pollution hazard generated by cement wash-off—that being the alkalinity (high pH) of the water.
- Any sediment traps placed within the road reserve must **not** represent a safety hazard to road users.



Cement washed onto porous soil

Controlling cement wash-off

- Concrete and cement have a greater potential to cause harm than sediment as a result of their effects of water pH.
- Wherever practical, cement wash-off should be directed to porous ground and/or an open trench excavated along the side of the treated surface.
- Wherever possible, avoid the use of exposed aggregate surfaces (e.g. driveways) unless the cement wash-off can be fully contained.



Cement wash flowing to kerb

Controlling cement wash-off

- Cement wash-off must not be allowed to flow freely into gutters, drains or receiving waters unless all reasonable and practicable measures are taken to direct this wash-off towards an excavated trench or earth filter.
- A flow control berm (e.g. sandbags, or bricks sand berm) can be formed down-slope of such building works (shown by arrows in photo) to direct sediment-laden water to open soil or infiltration trench.

Material stockpiles



Photo supplied by Catchments & Creeks Pty Ltd

Stockpile up-slope of sediment fence



Photo supplied by Catchments & Creeks Pty Ltd

Stockpile covered during wet weather



Photo supplied by Catchments & Creeks Pty Ltd

Sand delivered in bags

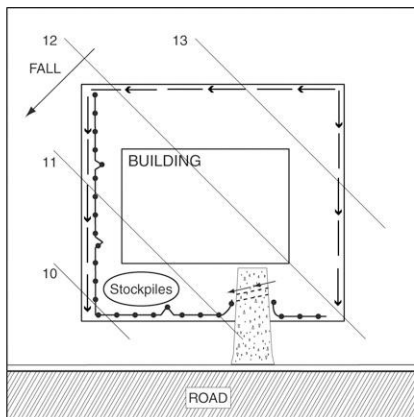

Diagram supplied by Catchments & Creeks Pty Ltd

Stockpile located away from overland flow

Material stockpiles

- Suitable material storage areas need to be located up-slope of the main sediment barrier (e.g. sediment fence).
- The building layout should allow sufficient room on the site for the storage of all building materials.
- No materials should be stored outside the property boundaries. Where unavoidable, council permission must be obtained before stockpiling materials within the road reserve.

Use of tarpaulins

- In addition to a down-slope sediment fence, stockpiles of clayey soil may require an impervious cover during periods of wet weather.
- On the other hand, stockpiles of clean sand that are located behind a sediment fence, will only need a protective cover if the sand stockpiles are likely to be exposed to strong winds.

Steep and confined sites

- In some regions, materials such as sand, can be delivered within large bags.
- On steep sites and sites with limited available space, erodible materials may need to be stored in commercial-sized bins or mini-skips.
- The use of mini-skips can be beneficial within the older commercial and residential areas of cities where space limitations are usually critical and the space between the building and property frontage is limited.

Drainage control

- Stockpiles of erodible material should be located away from overland flow paths.
- If this is not practical, then a flow diversion berm should be placed up-slope of the stockpile to divert overland flows around the stockpile.

Drainage control measures



Catch drain

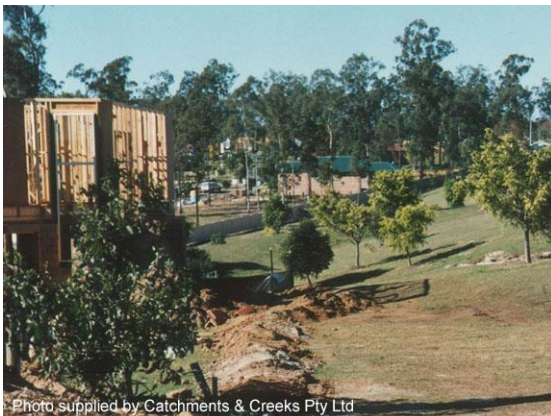

Flow diversion bank



Geotextile-lined drainage chute



Slope drain

Diversion of up-slope stormwater

- Wherever practical, stormwater run-off from up-slope areas should be diverted around soil disturbances.
- If the area of land up-slope of the soil disturbance exceeds 1500 m², then it is usually essential to divert stormwater run-off from such areas.
- In regions with well-defined wet and dry seasons, flow diversion is only likely to be warranted during those months when the rainfall is expected to exceed 45 mm.

Drainage control techniques

- Up-slope stormwater may be collected and moved across the site by constructing either *Catch Drains* (top) or *Flow Diversion Banks* (left).
- If the soils are known to be dispersive, then it is usually unadvisable to cut open drains into the soil, instead preference should be given to the use of flow diversion banks or piped drainage systems.

Temporary drainage chutes

- Filter cloth is commonly used to line short-term (< 3 months) drainage chutes. Do **not** use filter cloth on dispersive soils.
- ALL drainage *Chutes* require:
 - flow diversion banks, or similar, to direct flow into the chute
 - a well-defined inlet profile
 - a well-defined cross-sectional profile that can fully contain the flow (including splash) down the slope
 - a stable outlet and energy dissipation system at the base of the chute

Slope drains

- *Slope Drains* are flexible, solid-wall PVC pipes that can be used to direct up-slope stormwater run-off through confined building sites or down steep embankment.

Level spreaders

- *Level Spreaders* consist of either a 'turfed weir' or 'recessed log weir' placed at the end of a flow diversion bank or catch drain to discharge minor flows down a stable, grassed slope, or to release the run-off evenly into bushland.

Stabilisation of high-velocity drains



Photo supplied by Catchments & Creeks Pty Ltd

Temporary, filter cloth-lined drain



Photo supplied by Catchments & Creeks Pty Ltd

Turfed drainage channel



Photo supplied by Catchments & Creeks Pty Ltd

Stormwater drain lined with jute mesh



Photo supplied by Catchments & Creeks Pty Ltd

Sandbag check dam

Control of soil erosion

- If flow velocities within a constructed drain are expected to cause erosion, then the options are to either line the drain or control the flow velocity with *Check Dams*.
- Channel lining may consist of turf, filter cloth (left) or commercial erosion control mats.
- Check dams are normally formed from sandbags (see below).

Permanent drainage channels

- The site's permanent drainage system should be installed as soon as practical.
- This means that the drainage system can immediately be stabilised with the final surface treatment, such as turfing (left), rock lining, or concrete.

Erosion control mats

- Temporary *Erosion Control Mats* can be used to control soil erosion within temporary and permanent drains.
- In drainage channels, the most effective erosion control mats are either jute (plant-based) or coir (coconut fibre) mesh products.
- Most erosion control mats and mesh products allow grasses to grow through the mats.

Temporary velocity-control check dams

- The use of *Check Dams* on building sites is rare.
- In most cases the best solution is to protect high velocity drains with an appropriate channel lining.
- Check dams are most effective when used on drains with a gradient less than 10% (1 in 10).
- Rock-based check dams are generally only suitable for use in drains at least 500 mm deep.

Control of roof water



Photo supplied by Catchments & Creeks Pty Ltd

Permanent sub-surface drainage installed



Photo supplied by Catchments & Creeks Pty Ltd

Flexible, solid downpipe



Photo supplied by Catchments & Creeks Pty Ltd

Plastic downpipe



Photo supplied by Catchments & Creeks Pty Ltd

Sediment released from stormwater pipe

Installation of permanent drainage system

- To reduce soil erosion and site wetness, roof water should be discharged away from active work areas and any disturbed soil surface.
- The permanent sub-surface drainage system should be installed and ready to receive roof water prior to the framing inspection.

Temporary downpipes

- During those periods when there is a reasonable likelihood of rainfall, permanent or temporary downpipes should be installed as soon as the roof and guttering are laid.
- Temporary downpipes are normally used prior to final cladding or wall construction.
- The specification of roof water drainage controls is best identified on building plans through the use of technical notes (refer to page 21).

Temporary downpipes

- The use of temporary plastic downpipes has become common on building sites.
- These temporary drainage control measures can significantly reduce down-time and clean-up costs following extended periods of wet weather.
- **Extreme care must be taken to ensure twists do not exist within these light-plastic downpipes; otherwise, the plastic flow tubes will likely rip from the guttering during storms.**

Control of inflows

- During the building phase, stormwater entry into the sub-surface drainage system must be strictly controlled.
- Sediment and sediment-laden water should **not** directly enter the stormwater system without previously passing through an appropriate sediment trap or filter.

Stabilised site entry/exit points



Rock entry/exit pad



Rock entry/exit pad

Entry/exit pad

- Wherever reasonable and practicable, site access should be restricted to just one entry/exit point.
- All entry/exit points need to be stabilised to minimise:
 - the release of sediment-laden water from the building site; and
 - the trafficking of sediment onto an adjacent roadway.
- Stabilised rock pads also provide all-weather parking areas for work vehicles.

Rock pads

- Rock pads normally consist of a 150 to 200 mm thick layer of minimum 40 mm rock.
- The rock pad should be at least 2 m wide, and where practical, should extend from the kerb to the building slab.
- In rural areas and on large lots where the building is located well away from the roadway, the rock pad should be placed adjacent the sealed roadway and have a minimum length of 10 m.

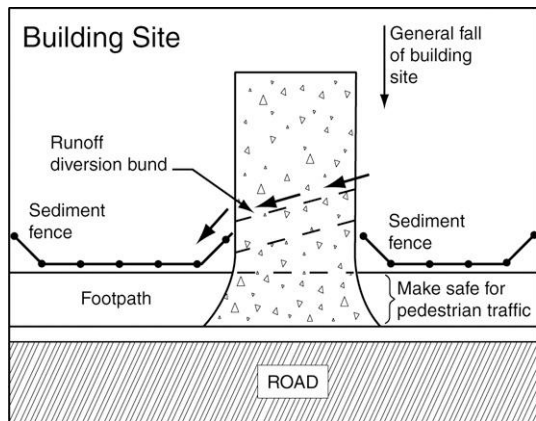

Drainage control

- If the building site is elevated above the road, then it is possible that stormwater run-off from the building site could potentially wash sediment from the entry/exit pad onto the roadway.
- To avoid this, it is usually necessary to construct a raised flow diversion berm across the rock pad (figures left & below) to direct stormwater run-off into an adjacent sediment trap such as a sediment fence.

Rock pad with flow diversion berm

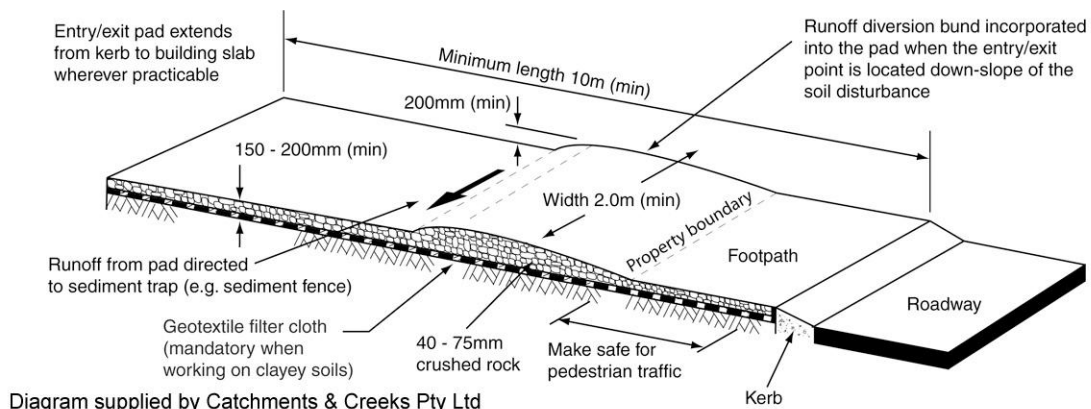

Standard dimensions of a rock pad for use on building sites

Sediment control measures



Retention of down-slope grass filter



Sediment fence



Sediment fence placed on verge



Mulch berms must be used with caution

Retention of existing grass

- On building sites, the primary sediment control device is normally a sediment fence.
- Unfortunately, a sediment fence on its own is unlikely to provide the desired entrapment of the fine-grained sediments that cause turbid run-off.
- Consequently, wherever practical the sediment fence should be supplemented with the retention of existing grassed areas to help filter sediment from run-off.

Use of sediment fence

- A sediment fence is **not** a filtration system.
- It is best to consider a sediment fence as a porous dam wall.
- Its primary job is to temporarily pond water during a storm, allowing the gravitational settlement of sediments within the ponded water.
- Therefore, a sediment fence **must** be constructed in a manner that allows the temporary ponding of water at regular intervals along the fence.

Placement of controls outside property

- Sediment controls must not be placed outside the property boundary unless specifically approved by the relevant road authority (usually the local council).

Alternatives to sediment fence

- Mulch berms can be an effective alternative to sediment fence.
- However, mulch berms can be easily damaged by vehicles driving over the berms.
- Regular (chipped) garden mulch **MUST NOT** be used. Instead a fractured, fibrous mulch is required to avoid the mulch berm simply washing away.
- Regular 'returns' (visible in photo) must be installed as per sediment fences.

Sediment fence

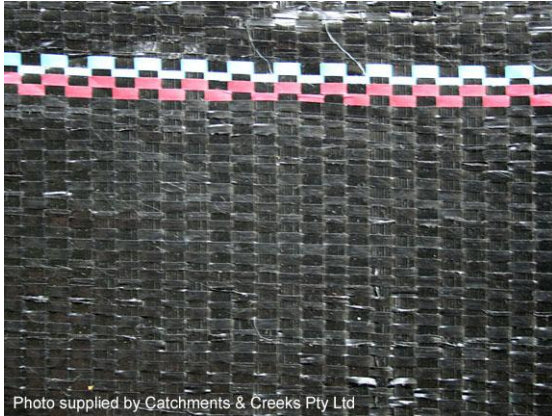

Sediment fence – woven fabric

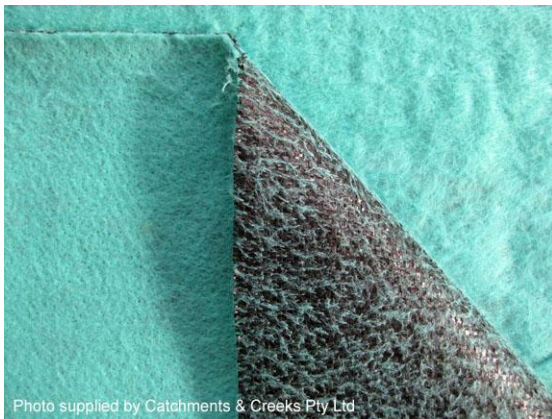

Sediment fence – composite fabric



Wire mesh backing



Placement of regular 'returns'

Use of woven sediment fence fabric

- Woven fabrics are made by weaving individual strips of impervious material into a fabric that allows water to weep through the 'overlaps' rather than through the actual strips of material.
- They are the most commonly used fabrics for sediment fence manufacture.
- Woven sediment fence fabrics are generally suited to most building sites, but sediment capture is generally limited to only the coarser-grained sediment particles.

Use of composite sediment fence fabric

- Composite fabrics consist of a woven fabric backing (black material in photo left) with a non-woven fabric stitched to the up-slope face (green material in photo left).
- Composite, non-woven fabrics are generally preferred on those building sites where a higher standard of sediment control is required.
- The non-woven (green) face must point up-slope.

Installation of a sediment fence

- Ideally a sediment fence should be installed along the land contour (i.e. along a line of constant elevation).
- On most building sites, however, it is not practical to install the fence along the contour, instead it is usually installed along the property lower boundary.
- Support post must be placed at max 2 m spacing unless the fence has a 'top wire' (anchored at 1 m spacing), or a wire mesh backing (left), in which case a 3 m spacing of support post is allowed.

Use of sediment fence 'returns'

- Sediment fences that extend beyond 10 m in length must incorporate 'returns'.
- Fence returns should extend at least 1 to 1.5 m up the slope.

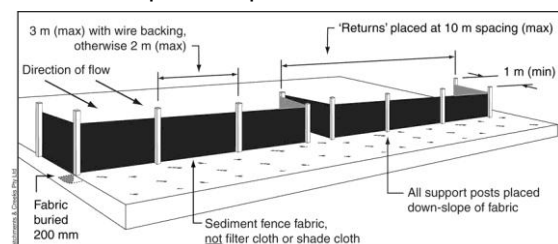

Sediment fence



Inappropriate use of shade cloth



Fence not returned up-slope at end



Toe of fabric incorrectly anchored



Post placed on wrong side of fence

Inappropriate fabrics

- Do **not** construct sediment fences from 'shade cloth' or open weave fabrics.
- Sediment fences generally should also not be constructed from filter cloth. The only exception being the formation of a sediment filter down-slope of a soil stockpile or as part of a de-watering operation.

Inappropriate installation techniques

- The ends of a sediment fence **must** be turned up the slope (a 'return') to prevent water simply passing around the ends of the fence.
- In the photo left, the final support post should have been placed up the slope near the retaining wall. This would have allowed water to pond up-slope of the sediment fence away from the grated stormwater inlet.

Inappropriate anchorage of fabric

- The bottom of the fabric **must** be anchored to prevent wash-outs.
- The bottom 300 mm of fabric **must** be suitably anchored either in a 200 mm deep trench, or under clean sand or aggregate (bottom right), but **not** randomly spaced rocks (left).
- The support posts must be placed down-slope of the fabric (**not** as shown below-left).

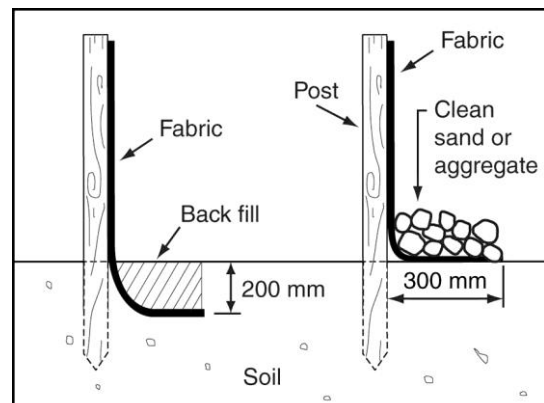

Recommended installation options

Kerb inlet sediment traps

Selection criteria for the use of kerb inlet sediment traps:

1. **Safety first** – do not use any sediment control system if that system represents a safety risk to persons or property. On open public roadways, consider the use of commercial gully bags to collect sediment within the gully chamber. Caution, sediment traps that extend into the trafficable lane may also represent a hazard to passing cyclists and motor vehicles.
2. **Flooding risk** – any adopted sediment control system must not result in flooding of neighbouring properties.
3. **Type of kerb inlet** – the choice of sediment control system depends on the type of kerb inlet. Kerb inlets located on the slope of a roadway (on-grade inlets) may incorporate gully bags or 'dam' type sediment traps (sandbags or filter socks) placed up-slope of the inlet.

Kerb inlets located at depressions in a roadway (sag inlets) may incorporate gully bags or 'barrier' type sediment traps (filter socks) placed around the inlet.

4. **Warning** – a sediment trap must not surround or block an 'on-grade' kerb inlet.



Photo supplied by Catchments & Creeks Pty Ltd

Gully bag

Gully bags

- Commercial gully bags are generally considered to perform better than sediment traps placed on the road surface.
- They are typically used when it is considered unsafe to cause ponding or sediment deposition on the roadway.
- The types of gully traps include the flexible filter bags (left) and solid filter boxes lined with filter cloth.

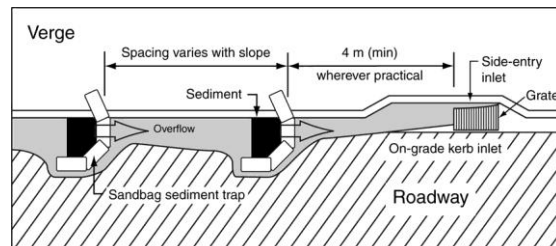

Photo supplied by Geofabrics Australasia

Filter sock sediment trap

On-grade kerb inlet sediment traps

- 'On-grade' inlets require a different sediment control system to 'sag' inlets.
- A series of sediment traps may be required to achieve optimum performance.



Sandbag sediment traps

- The use of a 'spillway' helps improve sedimentation by allowing the sediment-laden water to pass through the pond rather than around it.



Photo supplied by Catchments & Creeks Pty Ltd

Sandbag sediment trap

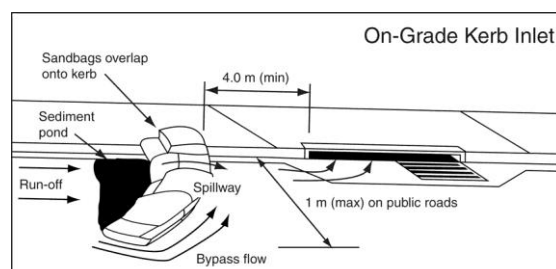

Kerb inlet sediment traps



Photo supplied by Catchments & Creeks Pty Ltd

Sag inlet sediment trap

Sag inlet sediment traps

- These types of sediment traps are used at 'sag inlets' at road depressions.
- As a general rule, the filter sock must not be allowed to fully block the kerb inlet. Exceptions apply only when:
 - there is no risk of causing flooding of adjacent properties; and
 - where there is a suitable stormwater bypass system within the adjacent property, such as a stable overland flow path



Photo supplied by Catchments & Creeks Pty Ltd

Sag inlet sediment trap

Alternative sag inlet sediment trap

- Alternative designs include filter socks and block and aggregate systems (below).

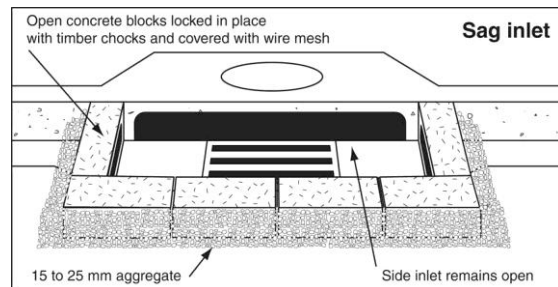

Photo supplied by Catchments & Creeks Pty Ltd

Inappropriate on-grade sediment trap

Inappropriate kerb inlet sediment traps

- Sediment traps must **not** be placed across the opening of 'on-grade' kerb inlets. This will cause the water to simply bypass the inlet and continue to flow down the roadway.
- To be effective, a sediment trap **must** be able to trap and retain sediment, not just divert the stormwater and sediment down the roadway!



Photo supplied by Catchments & Creeks Pty Ltd

Insufficient sediment control

Ineffective kerb inlet sediment traps

- A single sandbag is generally insufficient to provide adequate sediment control.
- Even the best sediment trap can become ineffective if not regularly maintained.

Grated inlet sediment traps

Selection criteria for the use of grated 'field' inlet sediment traps:

1. **Safety first** – do not use any sediment control system if that system represents a safety risk to persons or property.
2. **Flooding risk** – any adopted sediment control system must not result in flooding of neighbouring properties. A spill-through weir, or the like, may need to be incorporated into the sediment trap to control the depth and extent of ponding.

Table 19 – Preferred sediment control technique for various catchment conditions

Soil type	Small catchments	Medium catchments	Large catchments
Sandy soils	<ul style="list-style-type: none"> • Fabric wrap • Fabric drop inlet 	<ul style="list-style-type: none"> • Block & aggregate 	<ul style="list-style-type: none"> • Rock & aggregate
Clayey soils	<ul style="list-style-type: none"> • Filter sock • Fabric wrap or drop inlet using reinforced non-woven filter cloth 	<ul style="list-style-type: none"> • Block & aggregate incorporating filter cloth 	<ul style="list-style-type: none"> • Block & aggregate incorporating filter cloth



Photo supplied by Catchments & Creeks Pty Ltd

Fabric wrap inlet protection

Fabric wrap inlet protection

- Very small catchment areas.
- Most commonly used on building sites.
- Formation of the excavated pit is critical.

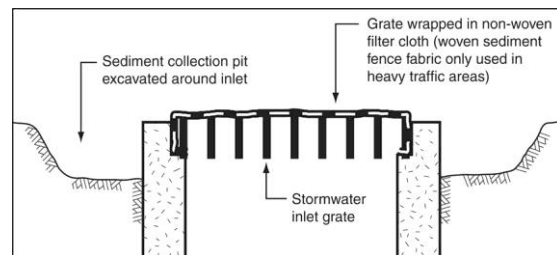
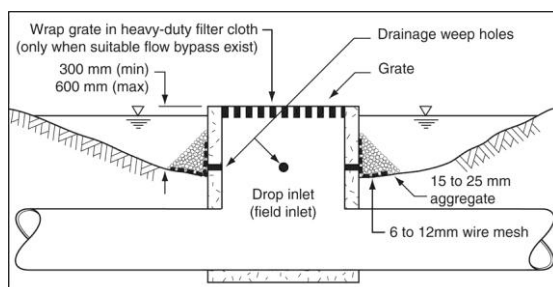

Photo supplied by Geofabrics Australasia

Filter sock drop inlet protection

Filter sock drop inlet protection

- Filter socks (including straw or compost-filled *Fibre Rolls*, and *Compost Berms*) are only suitable for small drainage areas (such as found on most building sites).
- Fibre (straw) filled socks are mostly suited to sandy soils.
- Compost berms or compost-filled socks work best in clayey soil areas.
- Compost-filled socks can adsorb some dissolved and fine particulate matter.



Excavated drop inlet protection

Excavated drop inlet protection

- Excavated drop inlet protection is used in locations where water ponding around the stormwater inlet is not allowed to reach a level significantly higher than the existing ground level.
- Safety issues may require the excavated pit to be surrounded by appropriate safety fencing.

Grated inlet sediment traps

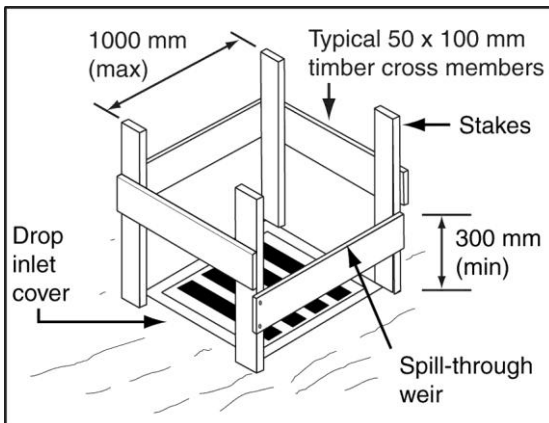

Photo supplied by Catchments & Creeks Pty Ltd

Fabric drop inlet protection

Fabric drop inlet protection

- Fabric drop inlet protection is best used in sandy soil regions.
- Suitable for relatively small catchment areas.
- Maximum spacing of support posts is 1 m (photo left is a poor example).
- A spill-through weir (below) normally needs to be incorporated into one side of the sediment trap to control the depth of ponding.



Installation of support frame

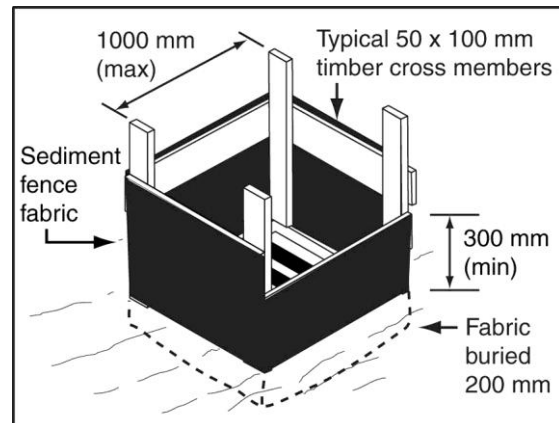

Placement of fabric

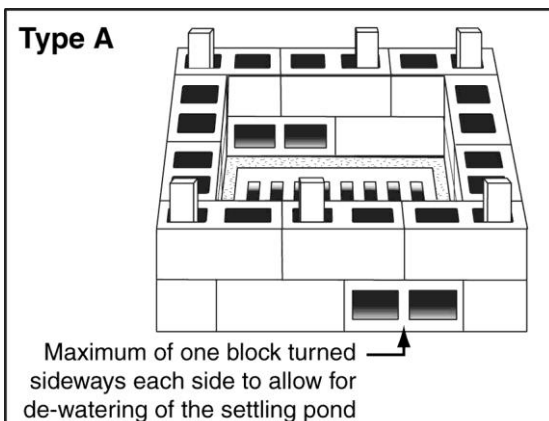

Photo supplied by Catchments & Creeks Pty Ltd

Block & aggregate drop inlet protection

Block & aggregate inlet protection

- Block & aggregate drop inlet protection is suitable for larger catchments.
- In clayey soils, filter cloth is placed between the aggregate and blocks to improve the removal of fine sediments.
- The depth of ponding upstream of the field inlet is governed by the height of the blocks.
- The diagrams below show two types of block arrangements (prior to placement of the aggregate).



Block details for low flow rate system

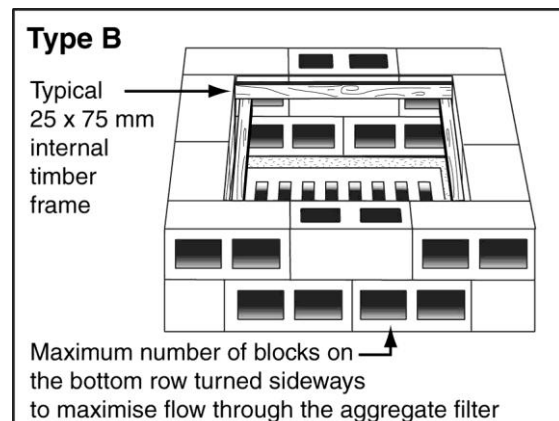

Block details for high flow rate system

Service trenches



Installation of services

- The installation of services can cause many problems to builders because:
 - the arrival of the service installers cannot always be reliably planned
 - the trench often extends beyond the main sediment fence
 - it can be impractical to stockpile earth and bedding material within any location other than the road reserve
- In all cases, builders must take all reasonable measures to minimise the release of sediment.



Excavated service trench

Sediment control measures

- Ideally, earth excavated from service trenches should be stockpiled behind the main sediment fence until ready for placement back in the trench.
- Wherever practical, the excavated earth should be placed up-slope of the trench to reduce sediment run-off during storms.
- Appropriate safety measures **must** always be applied.

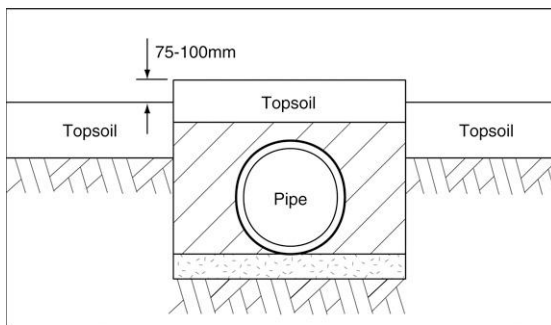

Backfilling of a service trench

Backfilling service trenches

- When backfilling service trenches, cap the trench with topsoil and compact to a level at least 75 to 100 mm above the adjoining ground level.
- This practice allows for some subsidence of the fill material, and ensures the fill is sufficiently compacted to avoid ongoing soil erosion.



Poorly backfilled service trench

Control of ongoing soil erosion

- Backfilled trenches should be appropriately stabilised, for example, covered with turf.
- If backfilled service trenches are not adequately stabilised, then ongoing soil erosion is likely to occur until a suitable grass cover is achieved.

Erosion control measures



Light mulch cover



Turf ready for laying



Rock mulched drain through garden bed



Temporary (jute) erosion control blanket

Stabilisation of finished earthworks

- Finished earthworks should be stabilised as soon as practical to minimise soil erosion.
- Erosion control measures are usually identified on the Erosion and Sediment Control Plan through the use of technical notes (refer to page 21).
- The extent of erosion control measures usually depends on the likelihood and intensity of expected rainfall.

Stabilisation of open surfaces

- Ideally, lawn areas should be turfed as soon as building activities are completed.
- Builders are encouraged to take the opportunity to include the supply and installation of such items within the building contract.

Stabilisation of drainage paths

- Areas that are likely to experience significant overland flow should be stabilised with rock mulching (left), erosion control blankets or turf.
- Both 'thick' and 'thin' erosion control blankets are available.
- The thin blankets perform a task similar to light mulching.
- The thick blankets (below-left) perform a task similar to that of heavy mulching, thus assisting in weed control.

Stabilisation of earth batters

- Newly formed earth batters should be covered with topsoil and stabilised as soon as possible.
- If the earth batters are to be grass seeded, then the application of light mulch (<50 mm) cover or 'thin' erosion control blanket can help to stabilise the slope.
- If the batter is to be vegetated with trees or shrubs, then the slope can be stabilised with a heavy mulch cover (50–100 mm) or a 'thick' erosion control blanket.

Maintenance of Control Measures

Site Maintenance



Photo supplied by Catchments & Creeks Pty Ltd

Maintenance of a sediment fence



Photo supplied by Catchments & Creeks Pty Ltd

Earth spilling over a sediment fence



Photo supplied by Catchments & Creeks Pty Ltd

Poorly located sand stockpile



Photo supplied by Catchments & Creeks Pty Ltd

Entry/exit pad in need of maintenance

Regular site inspections

- All drainage, erosion and sediment control measures must be checked regularly and maintained in good working order at all times.
- All control measures should be inspected at least weekly during dry weather, and daily during wet weather.
- Damaged items need to be repaired, even if it is not currently raining.
- Trapped sediment needs to be removed from the sediment trap.

Control of shifting earth

- Ensure that sediment control barriers have not been damaged by shifting earth or poorly stacked building materials.
- Sediment fences can be easily damaged by shifting earth and stockpiles.
- Stockpiled material should **not** lean against the sediment fence.

Earth and sand stockpiles

- Where necessary, relocate any materials stockpiled outside the main sediment control barrier.
- Materials that have been temporarily stockpiled on the verge should be relocated onto the property before the end of the working day.

Entry/exit pads

- Reapply crushed rock to entry/exit pads if excessive sediment build-up occurs.
- An excessive build-up of sediment on a rock pad is considered to exist when the rocks are not clearly visible and sediment is being transported onto the road.
- An excessive build-up of sediment on a roadway is considered to exist when the quantity of sediment deposited within any 1 m² area exceeds 500 grams (approx. small two handfuls).

Site maintenance



Photo supplied by Catchments & Creeks Pty Ltd

Clean-up tools

Cleaning-up spills

- Material spills (e.g. spilt sand, sediment and concrete) must be promptly clean-up.
- This means that suitable cleaning equipment must be available on-site.



Photo supplied by Catchments & Creeks Pty Ltd

Sediment fence in need of maintenance

Remove sediment after storms

- Following storms, excessive sediment should be removed from sediment fences and any other sediment traps.
- Material removed from sediment control devices must be disposed of in a manner that does not cause ongoing soil erosion or environmental harm.



Photo supplied by Catchments & Creeks Pty Ltd

Sediment cleared from roadway

Prompt collection of sediment from roads

- Sediment and other material washed from the work area, or transported onto roads by work vehicles, must be removed from gutters, drains and roads:
 - immediately if rain is occurring or imminent; or
 - immediately if considered a safety hazard; or
 - if items (i) or (ii) do not apply, before completion of the day's work.



Photo supplied by Catchments & Creeks Pty Ltd

Do NOT hose sediment down drains

Cleaning road surfaces

- The hosing of road surfaces to remove sediment must **only** occur in cases where sweeping has failed to remove sufficient deposited material and a safety risk remains.
- Appropriate sediment traps **must** exist while roads are being washed down.
- All reasonable and practicable measures **must** be used to minimise the release of sediment into stormwater drains.

Site check list

Location: Date:

- Site-generated dust and stormwater run-off are not causing nuisance or damage to adjoining properties.
- Up-slope stormwater run-off is managed to minimise soil erosion and site wetness.
- Stormwater run-off is not causing unacceptable levels of soil erosion.
- Roof water run-off is not causing unnecessarily soil wetness within active work areas.
- Site activities are being carried out in a manner that minimises the duration that disturbed areas are exposed to the erosive forces of wind, rain and flowing water.
- Soil erosion resulting from rainfall is being minimised.
- Soil erosion resulting from strong winds is being minimised.
- Sediment leaching from material stockpiles is not contaminating stormwater run-off.
- Exposed soil surfaces are being rehabilitated as soon as practicable to minimise soil erosion.
- Adequate precautions are being taken to minimise sediment leaving the work area as a result of site traffic.
- Site activities are not causing unacceptable levels of sediment to leave the work site.
- Sediment control measures are located fully within the property.
- Off-site material spills and sediment deposits have been cleared in a manner that minimises environmental harm, safety issues, and damage to public and private property.
- All reasonable and practicable measures are being taken to prevent concrete waste or wash-off entering gutters, drains and waterways.
- All reasonable and practicable measures are being taken to prevent contaminated water from cutting and cleaning activities entering gutters, drains and waterways.
- Drainage, erosion, and sediment control measures are being maintained in proper working order at all times.
- Safety risks associated with erosion and sediment control measures are being minimised, if not totally prevented.

Glossary of terms

Aggregate immersion test	An on-site soil test that can indicate the existence of a dispersive or slaking soil. The testing procedure involves filling a dish or jar with distilled water and immersing clumps of soil. The soil samples are then observed for their reaction over the next hour.
Building site	A site where the fabrication or erection of a building or structure is the primary activity.
Catch drain	A minor excavated drain, either temporary or permanent, used for such purposes as the diversion of stormwater around a soil disturbance.
Check dam	Small, regularly spaced, flow control structures that reduce the velocity of water in drains by 'damming' the water to increase the flow depth. Typically used to control soil erosion in newly formed drains, and/or to act as minor sediment traps.
Chute	A short open channel that conveys water down a steep slope.
Clayey soil	A soil that contains at least 20% clay. These soils readily form a clod when compressed in the hand, feel very smooth and sticky when wet, and are difficult to shovel when compacted.
Clay-sized particles	Sediment particles less than 0.002 mm in equivalent diameter.
Clean water	Water that either <ul style="list-style-type: none">– enters the property from an external source and has not been further contaminated by sediment within the property; or– water that has originated from the site and is of such quality that it either does not need to be treated in order to achieve the required water quality standard, or would not be further improved if it were to pass through a sediment trap.
Cut-and-fill earthworks	A process of slope modification in which soil is excavated from one section of a slope and used to construct an embankment below.
Dispersive soils	A structurally unstable soil that readily disperses into its constituent particles (clay, silt and sand) when placed in water. Moderately to highly dispersible soils are normally highly erodible and are likely to be susceptible to severe rilling and tunnel erosion.
Drainage control	Any system, procedure, or material employed to: <ul style="list-style-type: none">– prevent or minimise soil erosion caused by concentrated overland flow (including the management of rill and gully erosion); or– divert flow around or through a work site or soil disturbance; or– divert clean water away from a sediment trap; or– appropriately manage the movement of clean and dirty water through a work site.
Drop inlet	An inlet to a sub-surface drainage system located within an open area where the water falls vertically into a collection chamber.
Environmental harm	Any adverse effect, or potential adverse effect (whether temporary or permanent) on an environmental value.
Erosion and sediment control plan (ESCP)	A site plan, or set of plans, including diagrams and explanatory notes, that demonstrates proposed measures to control stormwater drainage, soil erosion, and sediment runoff on a building site.
Erosion control	The protection of soil or other granular material from erosion or measures taken to reduce potential erosion.

Erosion control blanket	A blanket of synthetic and/or natural material, used to protect soil against erosion caused by wind, rain and minor overland flows. The term 'blanket' generally refers to products best used in areas of sheet flow (e.g. on earth banks) rather than in drainage channels where 'erosion control <u>mats</u> ' are generally preferred.
ESC	Erosion and sediment control.
ESCP	Erosion and Sediment Control Plan.
Exchangable sodium percentage	The proportion of the cation exchange capacity occupied by sodium ions, expressed as a percentage. Sodic soils are categorised as those with an ESP from 6 to 14%, strongly sodic soils are those with an ESP of 15% or more.
Field inlet	An inlet to a sub-surface drainage system located within an open area where the water falls vertically into a collection chamber.
Filter cloth	Industrial grade, non-woven, synthetic fabric traditionally used to separate soils and rock of different textures or grain size, but also used as a short-term filter for the removal of medium to coarse sediment-particles from a liquid (usually water).
Filter fence	A filter fence is a type of filter barrier consisting of non-woven geotextile fabric staked as a vertical fence.
Flow diversion bank	Flow diversion banks typically consist of a raised earth embankment or tightly packed sandbags placed in such a manner to re-direct the flow of water.
Gabion	A basket filled with rocks, or similar material, usually rectangular in profile, used in the construction of retaining walls and erosion-control structures.
Heavy storm	Rainfall with: <ul style="list-style-type: none"> – an intensity equal to, or greater than, 10 mm/hr but less than 50 mm/hr; or – a total rainfall depth equal to, or greater than, the equivalent of the 1hr duration, 1 in 2 year average recurrence interval (ARI) design storm rainfall depth over a 24 hour period, but less than the equivalent of the 1hr duration, 1 in 10 year ARI design storm rainfall depth over a 24 hour period.
Jute	A strong vegetable fibre used in the making of temporary erosion control fabrics.
Level spreader	Finely contoured end-of-drain profile designed to allow concentrated flow to be released as even sheet flow over a nominated width of stable (usually grassed) land.
On-grade kerb inlet	Stormwater inlet formed into the kerb of a roadway where the roadway has a positive longitudinal grade (i.e. water approaches the inlet from only one direction).
Raindrop impact erosion	The spattering of soil particles caused by the impact of raindrops on the soil. The loosened particles may or may not be subsequently removed by run-off.
Rill erosion	The removal of soil by run-off from the land surface as sheet flow begins to concentrate in one or more small channels, generally up to 300 mm deep.
Road verge	That portion of the road reserve not covered by the carriageway or footpath.
Rock mattress	A low profile flexible rock-filled basket with a length and width significantly greater than its depth thus forming a 'mattress' like structure.

Rock pad	A well-defined, rock-lined surface (pad) placed immediately adjacent a sealed roadway over which vehicles access into or out-of a work site. Entry/exit pads are used to extract and retain sediment from the tyres of vehicles leaving a work site and act as all weather parking areas.
Run-off	That part of rainfall not lost to infiltration, evaporation, transpiration or depression storage, that ultimately flows from the drainage catchment.
Sag kerb inlet	Stormwater inlet formed into the kerb of a roadway where the roadway has a zero longitudinal grade (i.e. stormwater approaches the inlet from both directions).
Sandy soil	A soil that contains at least 50% sand. These are coarse-grained soils that are easy to shovel and break-up when compacted. It is very difficult to form a clod when these soils are compressed in the hand.
Sediment	Any clay, silt, sand, gravel, soil, mud, cement, fine-ceramic waste, or combination thereof, transported from its area of origin.
Sediment basin	A dam and associated basin used to capture and retain sediment-laden runoff from a land disturbance.
Sediment control	Any system, procedure or material used to filter, trap or settle sediment from sediment-laden water.
Sediment control zone	That portion of a work site that drains to a sediment control device, excluding the entry/exit pad.
Sediment fence	A purpose-made, woven or composite (non-woven with woven backing), geotextile fabric sediment trap constructed as a vertical fence in continuous (buried) contact with the ground and supported by posts.
Slab-on-ground	A construction process involving the fabrication of a structure on a reinforced concrete slab that forms the foundations to the structure.
Slaking soil	The partial breakdown of soil aggregates in water due to the swelling of clay and the rapid expulsion of air from pore spaces. It does not include the effects of soil dispersion.
Slope drain	A temporary drainage conduit (pipe) extending down the face of a newly formed or unstable slope. Typically used as a temporary drainage system to control soil erosion while the bank is being stabilised, or while the final drainage system is being constructed.
Sodic soil	A soil containing sufficient exchangeable sodium for the clay in the soil to readily disperse when placed in water.
Tunnel erosion	An erosion process involving the removal of sub-surface soil by water while the surface soil remains relatively intact. Water seeps through soil causing the dispersion and/or slaking of soil particles. The dispersed soil is then removed by seepage until the seepage path takes the form of a tunnel.
Turbidity	A measure of the clarity of water. Commonly measured in terms of Nephelometric Turbidity Units (NTU).