

Fish Passage Culvert Design

Part 2: Appendices A to F



Catchments
& Creeks

Version 2, 2026

Fish Passage Culvert Design

Part 2: Appendices A to F

Version 2, February 2026

Prepared and illustrated by: Grant Witheridge, Catchments and Creeks, Bargara, Queensland

Published by: Catchments and Creeks, Bargara, Queensland

Except as permitted under copyright laws, no part of this publication may be reproduced within another publication without the prior written permission of the publisher.

Permission, however, is granted for users to:

- store the complete document on a database, but not isolated parts of the document;
- print all or part of the document, and distribute such printed material to a third party;
- use extracts from the document for educational and training purposes.

All diagrams supplied by Catchments & Creeks remain the ownership of Catchments & Creeks. No diagram or photograph may be reproduced within another publication without the prior written permission of the Director of Catchments & Creeks.

This document should be referenced as:

Witheridge, G.M. 2026, *Fish Passage Culvert Design – Part 2: Appendices A to F*. Catchments & Creeks, Bargara, Queensland.

Cover image: Ewingar Creek culvert upgrade, North Ewingar Rd, Ewingar, NSW.

© Catchments & Creeks, 2026

Note to Reader:

Readers should note that this document has been prepared by a civil engineer, and the focus is on the engineering aspects of fish passage at engineering structures. The document has not been reviewed by a fisheries biologist.

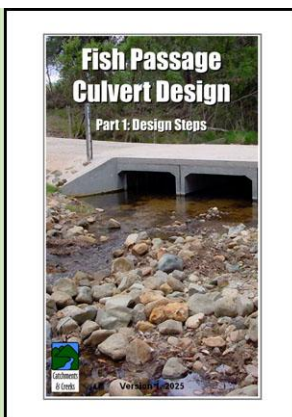
Disclaimer

To be effective, fish passage requirements at waterway crossings must be appropriately investigated, planned, and designed in a manner appropriate for the given work activity and site conditions.

Adoption of the recommendations and procedures presented within this document will not guarantee:

- (i) compliance with any statutory obligations
- (ii) compliance with fish passage outcomes
- (iii) compliance with the structural or flood control requirements of the culvert
- (iv) avoidance of environmental harm or nuisance
- (v) appropriate outcomes for waterways located outside of Australia.

Principal reference documents

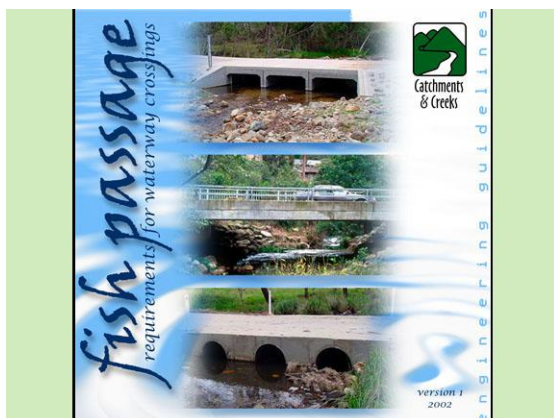


Catchments & Creeks, 2026

Fish Passage Culvert Design – Part 1: Design Steps

Grant M. Witheridge, Catchments & Creeks, Bargara, Queensland. 2025 (Draft).

Version 2, 2026

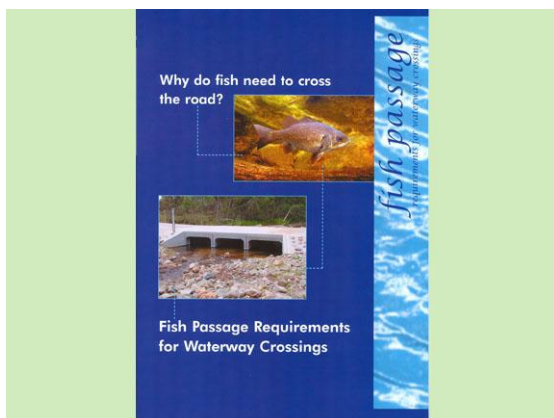


Catchments & Creeks Pty Ltd, 2002

Fish Passage Requirements for Waterway Crossings

Catchments & Creeks Pty Ltd. 2002 (CD-ROM).

[Discontinued following the release of this Field Guide.](#)



NSW Fisheries, 2003

Why do fish need to cross the road? – Fish Passage Requirements for Waterway Crossings

Fairfull and Witheridge, 2003, NSW Fisheries, Cronulla.



Tim Marsden, 2015

Common Rail Proof of Concept and Baffle Field Trial Assessment Report

Marsden, T. (2015) OceanWatch Australia: Culvert Fish Passage. Report to OceanWatch Australia. Australasian Fish Passage Services, 36pp.

Related *Catchments and Creeks* field guides

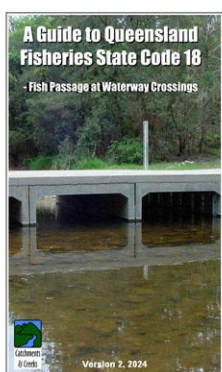


Catchments & Creeks Pty Ltd, 2017

A Glossary of Terms used in Culvert Fishway Design

Catchments & Creeks Pty Ltd, 2017, Brisbane Queensland.

This field guide provides photos and definitions of terms commonly used by engineers and fish biologists in the fish passage industry with specific reference to culvert design.

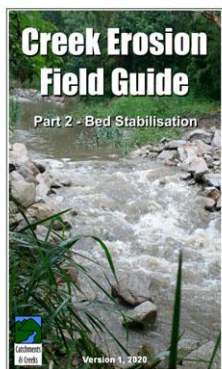


Catchments & Creeks, 2024

A Guide to Queensland Fisheries State Code 18

Catchments & Creeks, 2024, Bargara Queensland.

Published in October 2024.



Catchments & Creeks Pty Ltd, 2022

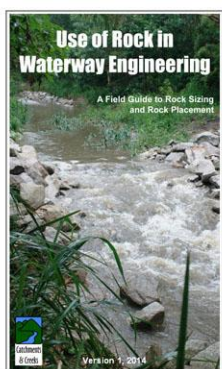
Creek Erosion Field Guide Part 2 – Bed Stabilisation

Catchments & Creeks Pty Ltd, 2022, Bargara Queensland.

Version 1, April 2021

Version 2, February 2022

Part 2 discusses the planning of creek erosion treatments, fish-friendly bed treatment, common properties of rock, the hydraulics of grade control structures, fish-friendly and non fish-friendly bed stabilisation techniques.



Catchments & Creeks Pty Ltd, 2020

Use of Rock in Waterway Engineering

Catchments & Creeks Pty Ltd, 2020, Brisbane Queensland.

Version 1, 2014

Version 3, 2020

A pictorial guide to the sizing and placement of rock within waterways.

Contents	Page
Purpose of field guide	6
About the author	6
Introduction	6
The layout of Part 2	7
Terminology	8
Baffle dimensional symbols	9
Appendix A – State by State Policies and Guidelines (2024)	
Introduction	11
Australian Capital Territory	16
New South Wales	17
Northern Territory	23
Queensland	24
South Australia	28
Tasmania	31
Victoria	35
Western Australia	47
Appendix B – The Design Team	
The design team	51
Listening to those people that raise concerns	52
Appendix C – An Introduction to Fish Passage and Fish Migration	
Introduction	54
Terminology	55
Types of fish migration	56
Fish-friendly waterways	57
The swimming ability of fish	58
Waterway hydraulics and its interaction with fish passage	59
Fish-friendly bed stabilisation measures	60
Appendix D – The Importance of the Boundary Layers	
Introduction	63
Terminology	64
Defining the flow velocity	65
Problems associated with the flume-tested fish swimming speeds	66
How fish use boundary layers to migrate along high-velocity streams	67
Critical properties of a fish-friendly boundary layer	68
Fish passage interaction with eddies and flow turbulence	69
Techniques for generating boundary layers	70
Appendix E – Baffle Selection and Design	
Introduction	72
The needs of the asset manager	73
Summary of sidewall baffle design	74
Summary of baffle spacing	75
Summary of the vertical positioning of short-length baffles	76
Positioning of baffles within single, twin-cell, and multi-cell culverts	78
Positioning of baffles in multi-cell culverts	79
E1 – Baffle design options	80
E2 – The needs of the waterway	97
E3 – The needs of fish (with respect to baffle design)	100
E4 – The needs of terrestrial fauna (with respect to baffle design)	102
E5 – The needs of the community (with respect to baffle design)	105
E6 – The needs of the asset manager (with respect to baffle design)	106
Appendix F – Baffle Engineering and Hydraulics	
Introduction	109
F1 – Baffle Width	111
F2 – Baffle Spacing	112
F3 – Vertical Position	127
F4 – Turbulence	128
F5 – Hydraulic Analysis	130
F6 – Possible construction steps	135

Purpose of field guide

This field guide has been prepared specifically to:

- provide educational information on fish passage at waterway culverts
- provide a quick reference guide to fish passage at culvert crossings
- provide a pictorial supplement to the various State Fisheries policies and design guidelines.

It is **not** the intention of this document to define the design standards for fish passage through waterway culverts. Such standards need to be set by Fisheries representatives from the various states and territories. This document is also **not** intended to be a detailed culvert design manual. Instead it is a 'supplement' to local Fisheries codes and engineering guidelines.

This document represents the opinions and recommendations of **just one person**, the author, who is a person **without** training in fish biology. As such, the document does **not** represent a holistic or balanced opinion. Readers should seek additional advice from local experts.

The photos presented within this document **do not necessarily represent current best practice**, but are intended to represent the current topic of discussion. It would be near impossible to obtain a 'perfect' example for each 'topic'. **No** image (photo) presented in this document should be considered **best practice** without full knowledge of the site conditions.

About the author

Grant Witheridge is a **retired** civil engineer with both Bachelor and Masters degrees from the University of NSW (UNSW). He has over 45 years of experience in the fields of hydraulics, creek engineering, and erosion & sediment control, during which time he had worked for a variety of federal, state and local governments, as well as private organisations.

Grant commenced his career at the UNSW Water Research Laboratory (1981) constructing and operating physical flood models of river floodplains. He later worked for Brisbane City Council on creek engineering and stormwater management issues, before ended his career working through his own company Catchments & Creeks Pty Ltd.

Introduction

No profession has a monopoly on the knowledge of the design of fish-friendly culverts.

No branch of the sciences has a monopoly on the knowledge of fish habitats and fish passage.

No branch of engineering has a monopoly on the design of culverts.

Any person, or profession, that claims to have a complete understanding of fish passage at waterway culverts is clearly suffering from an exaggeration of their own abilities. Culvert design is a team activity (as discussed in Appendix B).

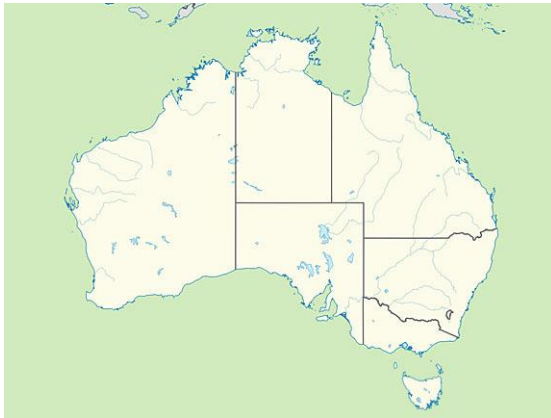
If we just take the engineering profession, the design of a culvert requires: hydrologic engineering for catchment analysis, hydraulic engineering for flow analysis, traffic engineering for functional design, geotechnical engineering for foundation design, structural engineering for structural design, handrail and guard rail design, and street lighting design. And I haven't even stepped into the construction phase.

The facts are simple. We all contribute **our little bit** of knowledge and expertise, and each little bit makes a major contribution to the overall success of a fish-friendly culvert design.

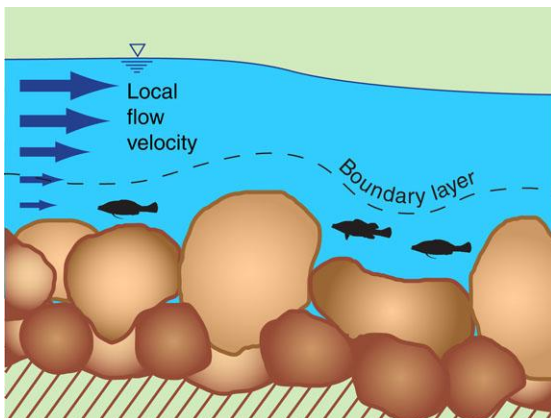
Each profession has their own use and meaning of technical terms. No profession has the sole authority over the definition of terms. The definitions I present in this publication align with the engineering profession because my target audience is the engineers that design waterway culverts.

I have had many discussions (arguments) with fisheries biologists only to eventually discover that we were both saying the same things, just using different terms to describe our position. What I call a rock chute, others call a rock ramp. What I call a hydraulic jump is different from what others call a hydraulic jump. However, we should all agree that common-use terms, as defined in a general dictionary, should retain their common-use definition.

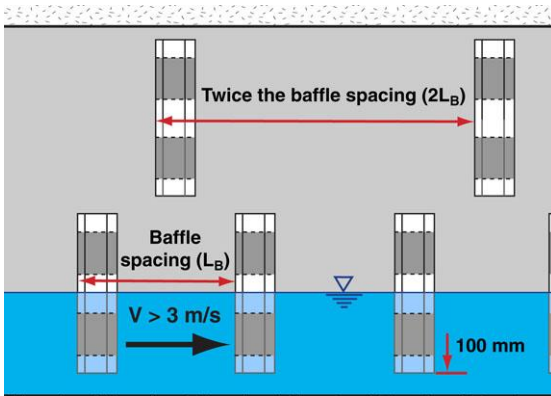
The layout of Part 2



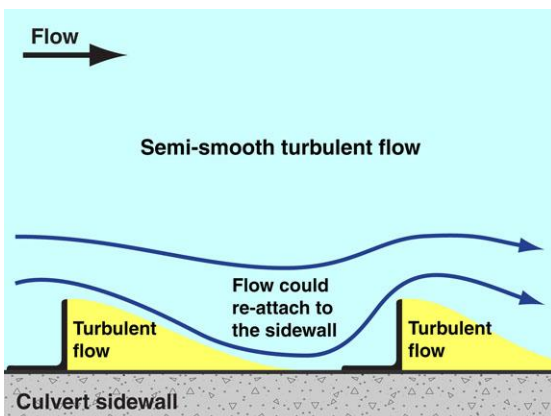
Australia



Boundary layer formed over a rocky bed



Baffle spacing



Baffle hydraulics

Appendix A – State by State Policies and Guidelines

- [Appendix A](#) contains a review of the current (2024) fish passage guidelines developed by the various States and Territories of Australia.
- A detailed discussion of Queensland's State Code 18 (2022) is presented in another field guide published by Catchments and Creeks in 2024.

Note: The author cannot guarantee that he has found the latest documents from each State and Territory.

Appendices B, C & D

Appendix B – 'Organising a Design Team'

- Typical personnel required in a team.

Appendix C – 'An Introduction to Fish Passage and Fish Migration'

- General information on fish passage.

Appendix D – 'The Importance of Boundary Layers'

- An explanation of boundary layer hydraulics.

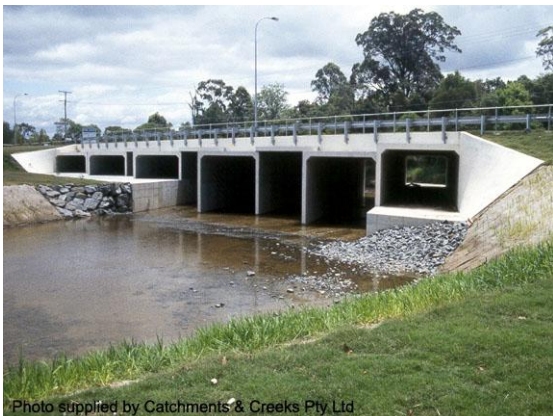
Appendix E – Baffle Selection and Design

- [Appendix E](#) aims to challenge your knowledge and bias towards culvert fish passage.
- Fish passage is not just about the things that YOU are interested in.
- Fish passage requires consideration of the needs of the waterway, the fish, the terrestrial fauna, the community, and the asset manager.
- It requires a holistic approach, not just an understanding of fish.

Appendix F – Baffle Engineering and Hydraulics

- [Appendix F](#) discusses the technical design of sidewall baffles, such as:
 - baffle width
 - horizontal spacing of baffles
 - vertical positioning of baffles
 - controlling turbulence
 - hydraulic analysis of baffled walls
 - possible construction steps.

Terminology



A culvert containing both wet and dry cells



Corrugated pipe culvert (NSW)



Australian Smelt (Queensland Museum)



Waterway, watercourse, creek or stream

Wet and dry cells

- Nominated 'wet' and 'dry' cells exist in order to promote the passage of both terrestrial and aquatic fauna.
- **Wet cells** have a floor level set below the normal dry-weather water level.
- **Dry cells** are designed to have a dry floor during low-flow conditions, which helps to promote native fauna movement.
- Each individual conduit in a culvert can be called a **conduit**, **cell**, **barrel**, or even a **culvert**.

Box, pipe and corrugated culverts

- A **box culvert** contains rectangular conduits.
- A **pipe culvert** contains circular (pipe) conduits.
- A **corrugated pipe culvert** contains corrugated, circular, metal conduits.
- An **arch bridge** is not considered to be a 'culvert' because it is not a fully enclosed conduit (i.e. the structure does not enclose the channel bed).

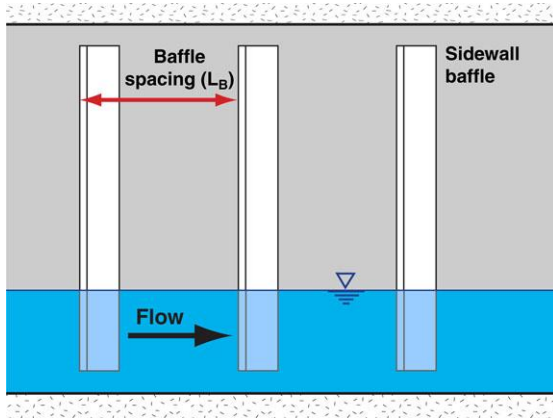
Fish

- With respect to fisheries legislation, the term '**fish**' typically means any animal species that, throughout its life cycle, lives:
 - in water (whether freshwater or saltwater)
 - in or on foreshores
 - in or on land under water.
- Readers should refer to their local fisheries legislation for their State or Territory definition of 'fish'.

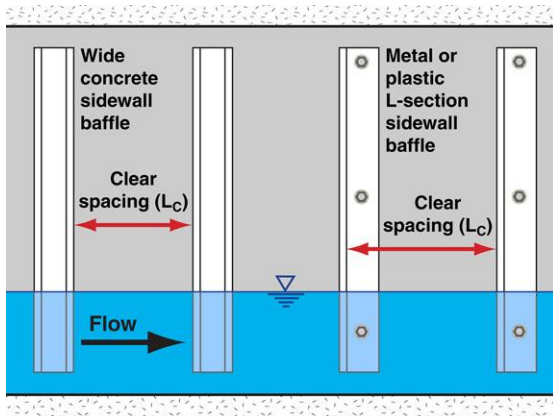
Waterway and fishways

- The term '**waterway**' typically includes a river, creek, stream, **watercourse**, drainage feature, or inlet of the sea.
- Readers should again refer to their local fisheries legislation.
- The term '**fishway**' refers to a constructed fish ladder, structure or device, by which fish can pass through, around, or over, a fish barrier—the term is more commonly associated with structures not defined as fish ladders.

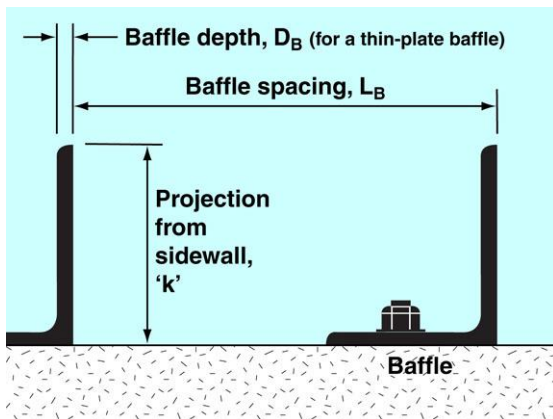
Baffle dimensional symbols



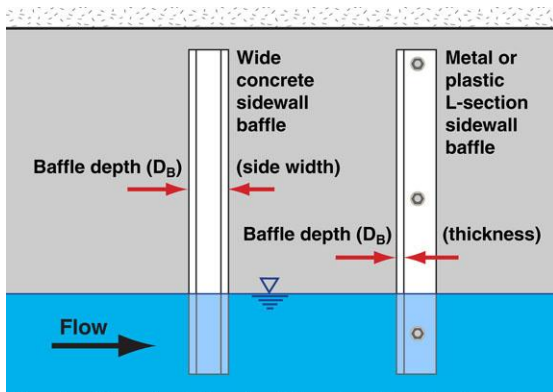
Baffle spacing



Clear spacing of baffles



Projected width of a baffle



Baffle depth

Baffle spacing (L_B)

- The **baffle spacing** (L_B) is defined as the distance between the leading edges of two consecutive baffles.

Note: The initial release of this three-part document was labelled as a DRAFT because of the uncertainty of a number of issues. In this draft I had mistakenly used the same symbol (W_B) for two different baffle dimensions (oops!). I believe that I have now resolved that error.

Clear spacing (L_C)

- The **clear spacing** (L_C) between adjacent baffles is defined as the baffle spacing (L_B) minus the baffle depth (D_B).

Projected baffle width (k)

- The **baffle width** (k) is the distance a baffle projects from the culvert floor or sidewall.
- Some documents may refer to this as the 'height' of a baffle if the baffle is mounted on the floor of a culvert.
- The symbol 'k' was chosen because it aligns with the hydraulic roughness parameter.

Baffle depth (D_B)

- The **baffle depth** (D_B) is the thickness of the 'projected' portion of the baffle as measured in the direction of water flow.
- For thin-plate L-section baffles, its depth is the thickness of the 'web' (as shown above, left).
- For thin-plate channel section (C-section) baffles, the depth (side width) is taken as the depth of the 'channel' when placed flat on its back.

Appendix A: State by State Policies and Guidelines (2024)

Introduction

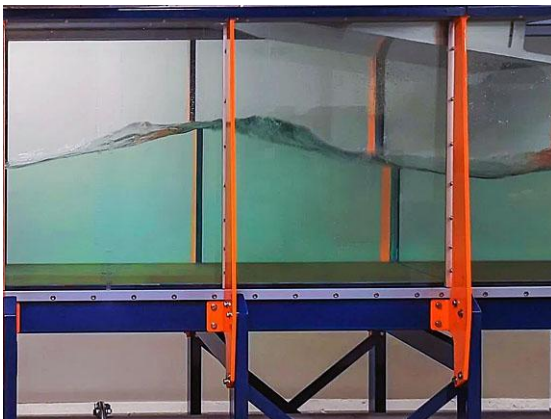


Raising a concern

References

- Akyildiz, I. F., D. Pompili, and T. Melodia. 2005. *Underwater acoustic sensor networks: research challenges*. *Ad hoc networks* 3:257-279.
- Barbarossa, V., J. Boemans, H. Wanders, H. King, M. Bierkens, M. Huijbregts, and A. Schipper. 2021. *Threats of global warming to the world's freshwater fishes*. *Nature Communications* 12:1701.
- Barrett, J., and M. Mallen-Cooper. 2006. *The Murray River's 'Sea to Hume Dam' fish passage program: Progress to date and lessons learned*. *Ecological Management & Restoration* 7:173-183.
- Bray, D. J. 2016. *Freshwater Fishes in D. J. G. Bray, M.F., editor. Fishes of Australia*. Museums Victoria and OzFishNet.
- Brink, K., P. Gough, J. Royte, P. P. Scholten, and H. Wannings. 2016. *From sea to source 2.0. Protection and restoration of fish migration in rivers worldwide*. World Fish Migration Foundation.
- Cafferata, P., T. Spittler, M. Wopat, G. Bundro, and S. Flanagan. 2004. *Designing Watercourse Crossings for Passage of 100-year Flood Flows, Wood, and Sediment*. California Forestry Report No. 1.
- Consuegra, S., R. O'Rourke, D. Rodriguez Barreto, S. Fernández, J. Jones, and C. Garcia de Leaniz. 2021. *Impacts of large and small barriers on fish assemblage composition assessed using environmental DNA metabarcoding*. *Science of The Total Environment* 790:148054.
- Cox, K. D., L. P. Brennan, S. E. Dudas, and F. Juanes. 2016. *Assessing the effect of aquatic noise on fish behavior and physiology: a meta-analysis approach*. *Proceedings of Meetings on Acoustics* 27.
- Cramp, R. L., C. E. Franklin, J. R. Watson, M. Parisi, D. Gomez Isaza, J. Keep, A. Toms, J. Shiau, and D. McPhee. 2021. *Mitigating and managing barriers to fish passage and improving river connectivity—final report*.
- DAF. 2019. *What is not a waterway barrier work?*

Example reference list



Glass-wall research flume



Photo supplied by Catchments & Creeks Pty Ltd.

Gravel-based waterway (Qld)

Dissemination of false information

- Unfortunately it would appear that even though many of our current (2025) government guidelines were generated from reliable research papers, some of the extracted information has been miss represented.
- Understanding the 'context' is extremely important when it comes to converting research science into engineering guidelines.

A likely source of reliable information

- The following is strictly a personal opinion based on 25 years as an outside observer of fish passage science.
- The most reliable information about culvert fish passage can usually be found within the **original** research papers—that being the research papers listed within the [References](#) of government guidelines.
- Unfortunately, it is not feasible for engineers to conduct their own review of research papers before designing a culvert.

Common 'mistakes' the author has found in government fish passage guidelines

The types of 'design' information that I believe is either misleading, or simply false, includes:

1. The presentation of maximum allowable flow velocities in fish-friendly culverts. Such information can be problematic for the following reasons:
 - the 'average' flow velocity within a culvert is meaningless to fish—what fish rely on is the boundary layer velocity and thickness
 - a culvert with an average velocity of 3 m/s could be fish friendly, while another culvert design with an average velocity of 1 m/s could be a fish barrier
 - much of this research is conducted at universities using smooth, glass-walled flumes that minimise boundary layer development.
2. Failure to recognise the importance of the type of waterway (clay, sand, or gravel).
3. A focus on the cruising speed of fish.
4. A misunderstanding of hydraulic principles and terminology.

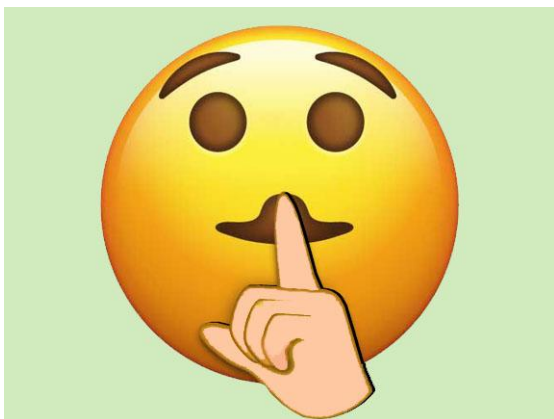
Drafting government codes and guidelines



Just checking



All good



Keep this a secret



Careful what you ask for

Introduction

- It is the author's experience that some government bodies use their codes and guidelines to 'ask' for things that their current legislation (Acts) do not allow them to ask for.
- I am **not** a legal expert, but it is **my understanding** that a guideline cannot require something that is not supported by current legislation (unless the actual guideline is recognised by the legislation).

Codes enforced by legislation

- **Fisheries codes**, which usually take the form of a development code, can be enforced by:
 - a clause in the State's Fisheries Act, or
 - the State's development/planning Acts.
- Codes normally apply only to:
 - works defined as 'development'
 - works that require government approval or licence.
- Such codes can introduce requirements that are not listed in current legislation.

Development codes

- If the State's Fisheries office introduces a **development code**, which is endorsed by the State's development or planning Act, then:
 - the fish passage requirements listed in the code will only apply while the development (e.g. culvert) is being built
 - readers should check if there is any legislation that requires the continued operation of these fish passage requirements **after** the construction works have been completed.

Design guidelines not enforced by legislation

- If the State's Fisheries office introduces a **design guideline** for such things as a waterway culvert, then:
 - the guideline cannot require any design feature that is not currently enforced by legislation (such as a Fisheries Act).
- If fish passage baffles are required to remain as an ongoing feature of the culvert, then such a requirement must appear within some form of legislation.

Essential input into the development of State guidelines



Photo supplied by Catchments & Creeks Pty Ltd

Identification of trapped species (Qld)

Fisheries biologist

- I am sure every professional would like to perform their work without interference by other professionals, and certainly not officers from another profession.
- **Fisheries biologists** provide us with expert knowledge of fish behaviour.
- In culvert design, input may be required from a biologist on species identification and expected migration patterns, which is essential if money is to be spent wisely on the culvert.



Photo supplied by Catchments & Creeks Pty Ltd

Meeting of culvert design experts (Qld)

Hydraulics expert

- In order to generate an appropriate State code, input is required from:
 - fisheries experts
 - hydraulics experts
 - waterways experts
 - civil construction experts.
- Hydraulic knowledge is required on many aspects of a culvert design, including:
 - catchment hydrology
 - flood mapping
 - blockage impacts.



Photo supplied by Catchments & Creeks Pty Ltd

Sediment deposition (USA)

Waterways expert

- A waterway expert is required to ensure that the fish passage features added to the culvert are compatible with the:
 - expected bed load migration (clay, sand, and gravel movement)
 - expected channel stability.
- Waterway experts can be found in:
 - the sciences
 - river morphology
 - civil engineering (creek engineering).



Photo supplied by Catchments & Creeks Pty Ltd

Culvert construction (NSW)

Culvert design, construction and maintenance personnel

- A knowledge of culvert construction practices can provide the following input:
 - knowledge of what is, and is not, achievable from a construction perspective
 - knowledge of the likely cost implications of suggested fish passage features
 - knowledge of expected construction and ongoing maintenance costs.

Classification of waterways within Australia

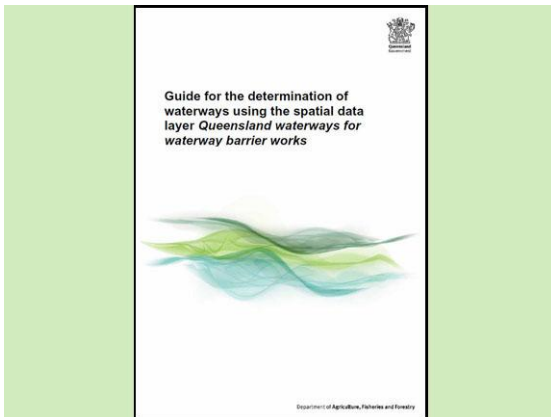


Photo supplied by Catchments & Creeks Pty Ltd

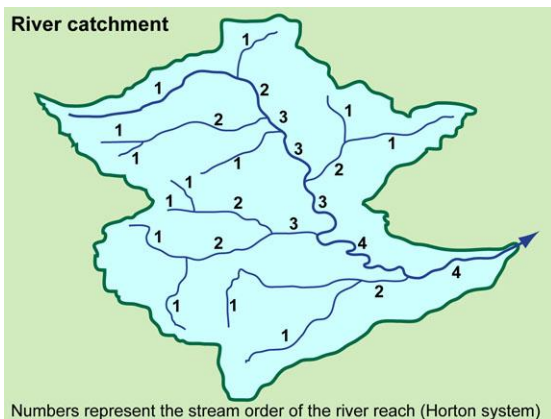
Reviewing catchment plans (SA)



NSW Policy and Guidelines, 2013



Qld spatial data users guide, 2013



Example of the Horton stream order

Classification systems

- Some States have mapped their waterways according to an adopted fish habitat classification system.
- Some States use a classification system based on a written description of the expected waterway attributes.

Warning:

The contents of this appendix will not age well, and are unlikely to be consistent with state policies beyond 2030.

NSW

- Fisheries NSW Policy and Guidelines for Fish Habitat Conservation and Management (2013 update).
- First published in 1998, updated in 1999.
- NSW Fisheries classify their fish habitats based on a [Class 1 to 4](#) system (refer to next page).

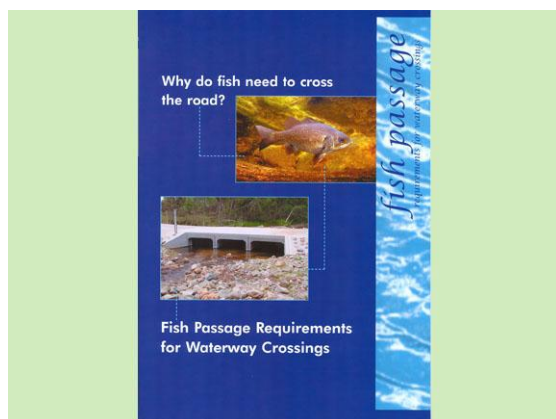
Queensland

- The waterway colour identifies the risk of adverse impact by a waterway barrier.
 - **Green**: low risk waterways
 - **Amber**: medium risk waterways
 - **Red**: high risk waterways still applicable for self-assessable works
 - **Purple**: highest risk waterways
 - **Grey**: tidal areas.
- It is unclear if this colour coding system is still being referenced by Qld Fisheries.

Stream order

- Some states use a stream order system for ranking the individual reaches of a waterway.
- In the [Horton system](#), a first-order stream has no contributing branches based on a specified mapping scale (the choice of map scale is critical).
 - a second-order stream has at least two contributing first-order branches
 - a third-order stream has at least two contributing second-order branches, etc.

Preferred choice of waterway crossing



NSW Fisheries, 2003

Why do fish need to cross the road? – Fish Passage Requirements for Waterway Crossings

(Fairfull and Witheridge, 2003, NSW Fisheries, Cronulla.)

This is an overview document that does not provide detailed design specifications.

The document does present a table (reproduced below) that lists the preferred crossing types for various water classes.

Table A1 – Preferred crossing type (NSW Fisheries, 2003)

Classification	Characteristics of waterway type	Minimum [1] recommended crossing type
Major fish habitat Class 1 (NSW) Purple Zone (Qld)	Major permanently or intermittently flowing waterway (e.g. river or major creek), habitat of a threatened fish species.	Bridge, arch structure or tunnel
Moderate fish habitat Class 2 (NSW) Red Zone (Qld)	Named permanent or intermittent stream, creek or waterway with clearly defined bed and banks with semi-permanent to permanent waters in pools or in connected wetland areas. Marine or freshwater aquatic vegetation is present. Known fish habitat and/or fish observed inhabiting the area.	Bridge, arch structure, culvert [2] or ford
Minimal fish habitat Class 3 (NSW) Amber Zone (Qld)	Named or unnamed waterway with intermittent flow and potential refuge, breeding or feeding areas for some aquatic fauna (e.g. fish, yabbies). Semi-permanent pools form within the waterway or adjacent wetlands after a rain event. Otherwise, any minor waterway that interconnects with wetlands or recognised aquatic habitats.	Culvert [3], or ford
Unlikely fish habitat Class 4 (NSW) Green Zone (Qld)	Named or unnamed waterway with intermittent flow following rain events only, little or no defined drainage channel, little or no flow or free standing water or pools after rain events (e.g. dry gullies or shallow floodplain depressions with no permanent aquatic flora present).	Culvert [4], causeway or ford

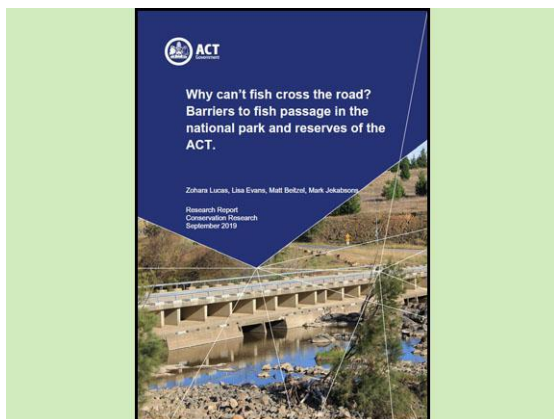
[1] In all cases bridges are preferred to arch structures, culverts, fords and causeways (in that order).

[2] High priority given to the [High Flow Design](#) procedures presented for the design of these culverts - refer to Design Considerations section of this document, or engineering guidelines.

[3] Minimum culvert design using the [Low Flow Design](#) procedures; however, [High Flow Design](#) and [Medium Flow Design](#) should be given priority where affordable.

[4] Fish friendly waterway crossing designs possibly unwarranted. Fish passage requirements should be confirmed with the local fisheries department/authority.

Australian Capital Territory



Barriers to fish passage, 2019



Recessed culvert on Bogong Creek, ACT



Gravel-bed, Tidbinbilla Ring Road, ACT



Burkes Creek Road crossing, ACT

'Why can't fish cross the road? Barriers to fish passage in national park and reserves of the ACT', 2019

Lucas, Z., Evans, L., Beitzel, M. and Jakobsons, M. 2019. *Why can't fish cross the road? Barriers to fish passage in national park and reserves of the ACT.*

Research Report Series. Environment, Planning and Sustainable Development Directorate. ACT Government, Canberra.

Report recommendations:

1. Keep fish passage as a consideration when building, maintaining and planning vehicle crossings over streams.
2. Design crossings that allow fish to pass.
3. Maintain existing crossings that already allow fish passage.
4. When maintaining or upgrading roads, modify those crossings that are barriers to fish passage.
5. Prioritise the improvement of crossings identified in this report as 'environmental priorities'.

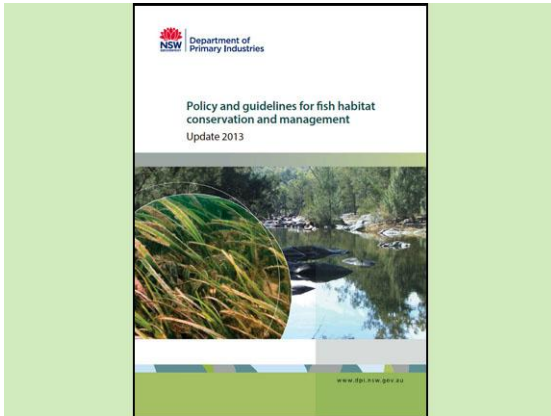
Common features of fish-friendly culverts in the ACT

- A flow depth that matches the depth of the natural upstream and downstream water channel, and the streambed is not raised.
- The velocity of the upstream and downstream water channel is maintained, and natural substrate is maintained throughout crossing.
- A span that matches the width of the upstream and downstream water channel.

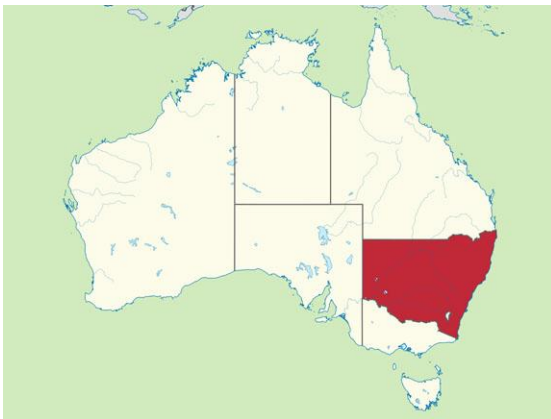


Ford crossing over Cotter River, ACT

New South Wales – Fisheries Policy and Guidelines (2013)



Policy and Guidelines for Fish Habitat

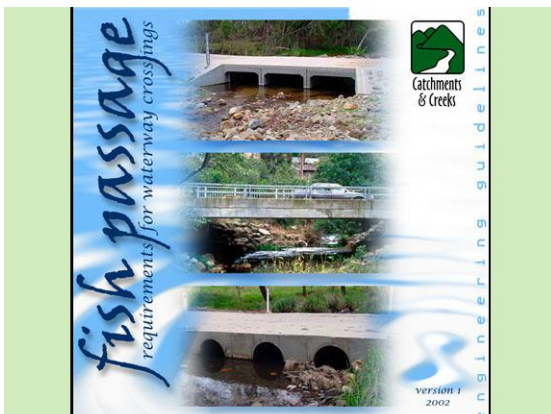


New South Wales



Photo supplied by Catchments & Creeks P/L

Bridge construction, Nepean River, NSW



Witheridge, 2002 (superseded)

'Policy and guidelines for fish habitat conservation and management' (2013 update)

Sarah Fairfull, Manager (Fisheries Ecosystems), Fisheries NSW, Wollongbar.

Published by the NSW Department of Primary Industries, a part of the Department of Trade and Investment, Regional Infrastructure and Services. Sydney, NSW.

ISBN 978 1 74256 283 4

Chapter 4. *In-stream structures and barriers to fish passage*

4.1 Obstructions to fish passage

- Barriers to fish passage can occur at: dams, weirs and [waterway crossings](#), which can:
 - impede natural flows
 - create a physical barrier
 - create a hydrologic barrier.
- Fish passage barriers can also exist within floodplains, including flood-control levees, floodgates, sediment basins, gross pollutant traps, and other water treatment devices.

4.1.2 Policy & guidelines for fish passage

- A permit is required for all works that may obstruct the fish passage in Type 1, 2 & 3 habitats.
- NSW DPI assessment required for:
 - works across full channel width
 - works that alter instream flow velocities
 - works affecting tidal flows
 - potential 'temperature' pollution.
- Avoid works during September to March.
- Avoid works during periods of high flow.

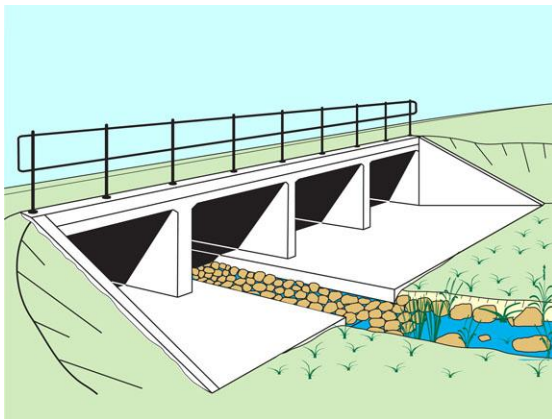
4.2 Waterway crossings

- The NSW document refers back to:
 - Fairfull and Witheridge (2003), and
 - Witheridge (2002), which is now superseded by this field guide.
- The document also refers to the 'preferred crossing type' previously presented in this appendix as Table A1.
- The factors that must be considered in the design of waterway crossings also includes: public safety, social and budgetary constraints.

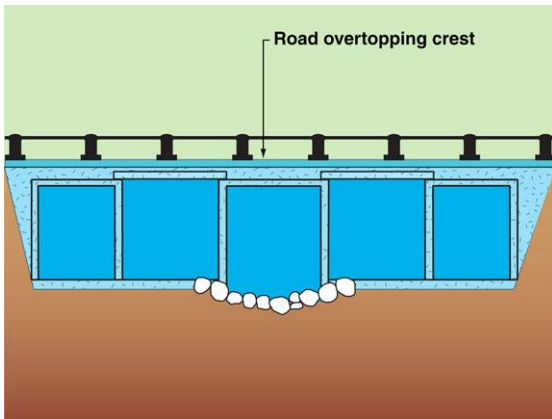
New South Wales – Guidelines for Fish Habitat Conservation (2013)



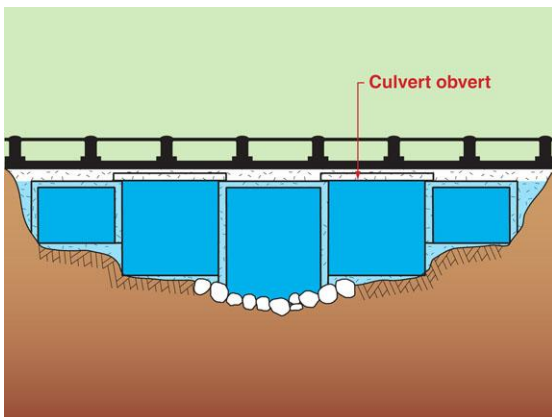
Culvert reconstruction (NSW)



Box culvert with low-flow channel



High Flow Design (overtopping flows)



Medium Flow Design (full culvert flow)

4.2.2 Policy and guidelines for waterway crossings

- When planning for the rehabilitation of fish passage barriers (culverts) along a waterway, the focus should be on those barriers located at the lowest end of the catchment where the numbers and diversity of fish species are the greatest.
- Where feasible, efforts should also focus on TYPE 1 habitats where threatened fish species are known to occur.

Recessed culverts

- For waterway crossings incorporating culverts (including low-flow cells), a minimum of 300 mm of water should pool through the structure, with a centrally placed low-flow cell being preferable.
- Waterway crossings should be constructed perpendicular to the flow of the water, and should be positioned away from channel bends.

Minimum flow area

- A **High Flow Design** requires a minimum culvert flow area equal to the **stream's natural flow area** below the crossing's overtopping weir elevation.
- Where this is not feasible, the second priority would be a **Medium Flow Design** based on the culvert's obvert level.
- In all cases, the culvert should be designed to maximise the geometric similarities of the natural channel profile from the bed of the culvert up to a flow depth of 0.5 metres (**'Low Flow Design'**).

Emergency culvert repairs

- In the case of the need for emergency waterway crossing repair works, NSW DPI should be notified of the proposed emergency repair works prior to their commencement.
- A permit will be issued subject to the receipt of full documentation as outlined in the DPI guidelines.
- The submitted documentation should address how the crossing will eventually be permanently repaired (where relevant).

New South Wales – Classification of waterways for fish passage



Photo supplied by Catchments & Creeks Pty Ltd

Macquarie River, NSW

Class 1

- Major key fish habitat.
- 'Marine or estuarine waterway or permanently flowing or flooded freshwater waterway (e.g. river or major creek), habitat of a threatened or protected fish species or 'critical habitat.'
- (Could be considered the equivalent of Queensland's Purple and Grey zones.)



Photo supplied by Catchments & Creeks Pty Ltd

Four Mile Creek, northern NSW

Class 2

- Moderate key fish habitat.
- 'Non-permanently flowing (intermittent) stream, creek or waterway (generally named) with clearly defined bed and banks with semi-permanent to permanent waters in pools or in connected wetland areas. Freshwater aquatic vegetation is present. Class 1 and 2 habitats present.'
- (Could be considered the equivalent of Queensland's Red zones.)



Photo supplied by Catchments & Creeks Pty Ltd

Permanent pools, ephemeral creek, NSW

Class 3

- Minimal key fish habitat.
- 'Named or unnamed waterway with intermittent flow and sporadic refuge, breeding or feeding areas for aquatic fauna (e.g. fish, yabbies). Semi-permanent pools form within the waterway or adjacent wetlands after a rain event. Otherwise, any minor waterway that interconnects with wetlands or other Class 1, 2 & 3 fish habitats.'
- (Could be considered the equivalent of Queensland's Amber or Green zones.)

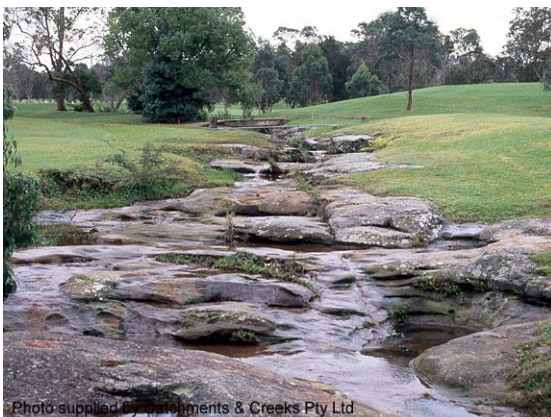


Photo supplied by Catchments & Creeks Pty Ltd

Unnamed rocky waterway, Sydney, NSW

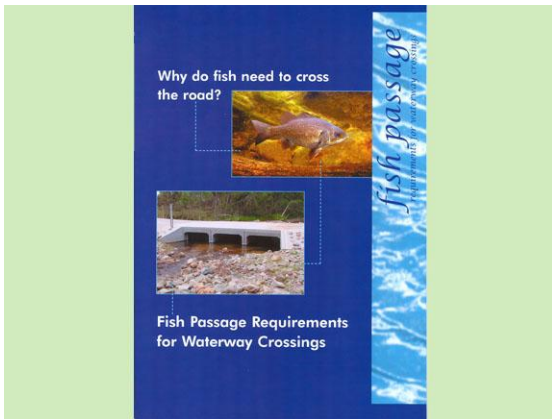
Class 4

- Unlikely key fish habitat.
- 'Waterway (generally unnamed) with intermittent flow following rain events only, little or no defined drainage channel, little or no flow or free standing water or pools post rain events (e.g. dry gullies or shallow floodplain depressions with no aquatic flora present).'
- (Could possibly be considered the equivalent of Queensland's Green zones, but more likely a non-classified fish habitat.)

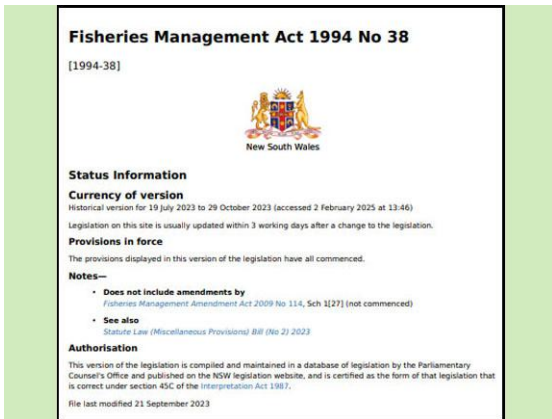
New South Wales (Policy and Guidelines for Waterway Crossings, 2008)



NSW fish friendly waterway crossings



Fairfull and Witheridge, 2003



Fisheries Management Act, 1994



Photo supplied by Catchments & Creeks Pty Ltd

Tidal culvert (Brunswick Heads, NSW)

'Policy and Guidelines for Fish Friendly Waterway Crossings'

NSW Department of Primary Industries (DPI), 2008

Aquatic Habitat Protection Unit

Cronulla, New South Wales, Australia

(This brochure provides a summary of the specific legislation and policy requirements that must be observed by those intending to plan, design and construct waterway crossings in NSW.)

Key references

- 'Why do Fish Need to Cross the Road? Fish Passage Requirements for Waterway Crossings' (Fairfull and Witheridge 2003) NSW DPI, Cronulla, NSW.
- 'Policy and Guidelines for Aquatic Habitat Management and Fish Conservation' (NSW DPI 1999).
- Witheridge, G. (2002) 'Fish Passage requirements for Waterway Crossings - Engineering Guidelines'. Catchment and Creeks Pty Ltd, Brisbane, Queensland.

Legislation

- The activity of constructing waterway crossings may require approval under Part 7 (Div 3) of the [Fisheries Management Act 1994](#) to dredge and/or reclaim.
- Dredging works may be required to construct the footings or foundations for the crossing.
- Generally, a local government authority or individual will require a permit to carry out any dredging or reclamation work unless the works are authorised by another public authority (other than a local government).

Tidal waters

- Waterway crossings constructed in tidal waters may also require a permit under Part 7 (Div 4) of the [Fisheries Management Act 1994](#) if the construction is likely to harm marine vegetation such as seagrass, mangroves, or marine macroalgae (seaweeds).
- **Caution:** When clearing a site prior to culvert construction, or post-flood maintenance, confirm with authorities any approvals required to remove any living or dead mangrove timber.

New South Wales (Policy and Guidelines for Waterway Crossings, 2008)



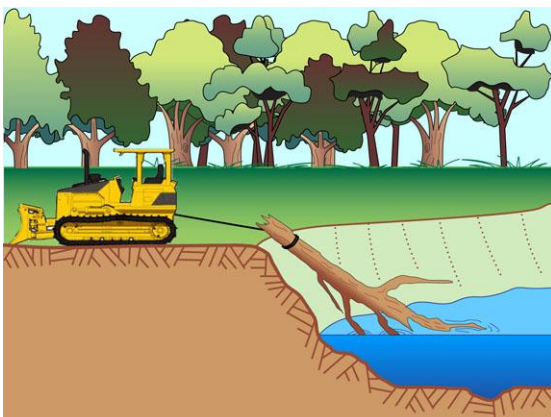
Catchment planning (Lismore, NSW)



Bridge construction (NSW)



Arch bridge construction (NSW)



Snag removal (least desirable option)

Site planning

- For any waterway crossing proposal, an [aquatic habitat and fish assessment](#) should be undertaken.
- When planning for the rehabilitation of fish passage barriers (culverts) along a waterway, the focus should be on those barriers located at the lowest end of the catchment where the numbers and diversity of fish species are greatest.

Construction phase

- Fish passage must not be restricted at any time, unless the appropriate permit has been granted by NSW DPI.
- If a project requires fish passage to be temporarily blocked, and no feasible alternative exists, then NSW DPI must be informed, and a permit must be obtained before the works are commenced.
- The timing of the works should minimise the potential interference of known fish migration events.

Construction phase

- Spawning grounds, such as gravel beds in areas where salmon or trout are likely to occur, must not be dredged or removed from within a waterway unless approval has been granted by NSW DPI.
- Woody snags should be managed with lopping as the first priority rather than snag removal.

Removal of snags

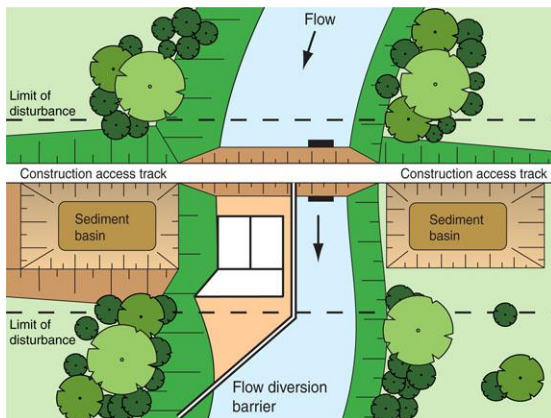
- Where lopping will not solve the problem, re-alignment should be considered as the next possible management option, followed by relocation.
- Removal of a snag is the least desirable alternative, and should only be adopted as a last resort.
- Local councils and other public authorities are required to notify NSW DPI of any proposed works, which involve the lopping, realignment, or removal of snags.

New South Wales (Policy and Guidelines for Waterway Crossings, 2008)

Table 1 – Preferred crossing type (NSW Fisheries, 2003)

Classification	Characteristics of waterway type	Minimum [1] recommended crossing type
Major fish habitat Class 1 (NSW) Purple Zone (Qld)	Major permanently or intermittently flowing waterway (e.g. river or major creek), habitat of a threatened fish species.	Bridge, arch structure or tunnel
Moderate fish habitat Class 2 (NSW) Red Zone (Qld)	Named permanent or intermittent stream, creek or waterway with clearly defined bed and banks with semi-permanent to permanent waters in pools or in connected wetland areas. Marine or freshwater aquatic vegetation is present. Known fish habitat and/or fish observed inhabiting the area.	Bridge, arch structure, culvert [2] or ford
Minimal fish habitat Class 3 (NSW) Amber Zone (Qld)	Named or unnamed waterway with intermittent flow and potential refuge, breeding or feeding areas for some aquatic fauna (e.g. fish, yabbies). Semi-permanent pools form within the waterway or adjacent wetlands after a rain event. Otherwise, any minor waterway that interconnects with wetlands or recognised aquatic habitats.	Culvert [3], or ford
Unlikely fish habitat	Named or unnamed waterway with intermittent flow following rain events only, little or no defined	Culvert [4], causeway or ford

Table A1 (presented earlier in document)



Staged culvert construction (ESCP)



Photo supplied by Catchments & Creeks Pty Ltd

Long-term stockpile (bridge works, NSW)



Photo supplied by Catchments & Creeks Pty Ltd

Instream flow-diversion silt curtain (NSW)

Critical habitats

- Where aquatic habitats are designated 'critical habitat' under Part 7A of the *Fisheries Management Act 1994*, then the waters of that habitat must automatically be designated a Class 1 waterway, and will be subject to the preferred engineering solutions outlined (Table A1 of this field guide).
- A SIS must also be prepared for the works.

Erosion and sediment control

- Where a road project is likely to involve the loss of aquatic habitat, NSW DPI will request that habitat rehabilitation, or environmental compensation, be used to mitigate the damage.
- All possible care should be taken to ensure that sediment from road works does not enter any waterways.
- [Erosion and Sediment and Control Plans \(ESCPs\)](#) should be developed and implemented and copies made available to NSW DPI on request.

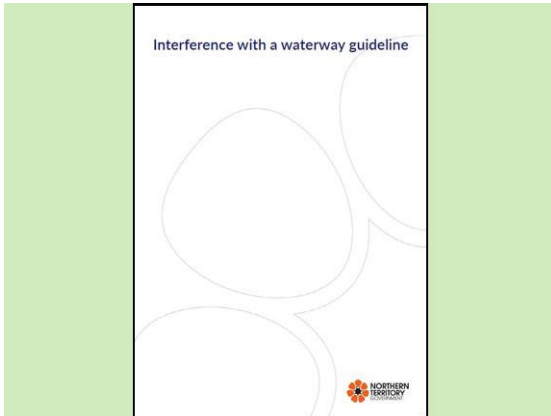
Construction site stockpiles

- In order to minimise sedimentation, fill or excavated material must not be stockpiled in flood prone areas.
- Particular care should be taken in siting stockpiles and dumps.
- Sites should be situated either above mean high water mark in tidal areas, or be secure from a 1 in 10 year flood level and have effective sediment control works to contain any runoff.

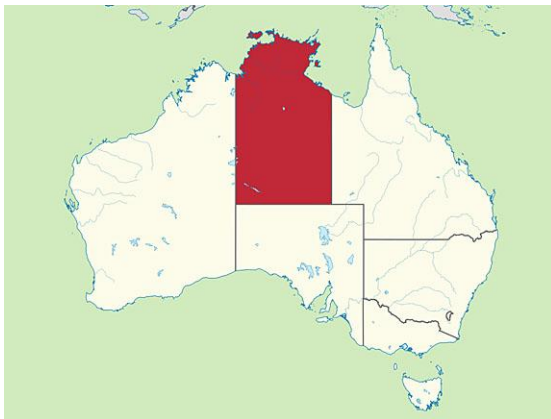
Post-works sediment controls

- Sediment controls along drainage lines should be left in place to control sediment entering a waterway after the construction phase is completed, and until the site has been fully stabilised.

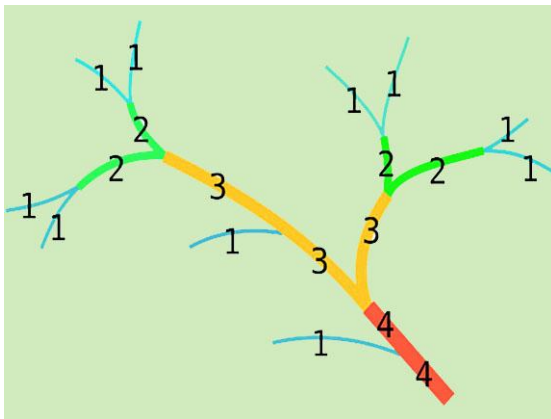
Northern Territory



Interference with a waterway guideline



Northern Territory



Strahler stream order



Photo supplied by Catchments & Creeks Pty Ltd

Culvert construction (NT)

'Interference with a waterway guideline', 2024

Department of Environment, Parks and Water Security Water Resources Division, Water Resources. January 2024.

DEPWS@nt.gov.au

TRM number: LRM2020/0106-0004~0002.

Permits

- If you want to carry out an activity in a waterway in the Northern Territory (NT), you may need to apply for a permit.
- However, you don't need a permit if you're building:
 - **culverts**, bridges and urban stormwater drainage works that meet engineering standards accepted by the relevant public authority.

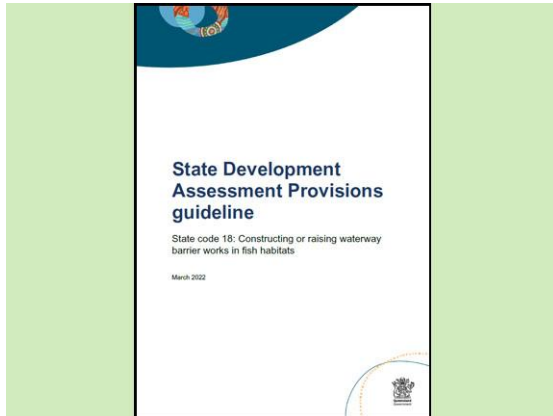
Stream order

- Stream orders 3 and 4 may be referred to as creeks, although some are more significant like Dry River and King River, which both flow into the Katherine River.
- Stream orders 5 to 7 include the major rivers such as the Finke, Todd and Adelaide rivers, which are classified as stream order 6, and the Roper and Daly rivers, which are stream order 7.

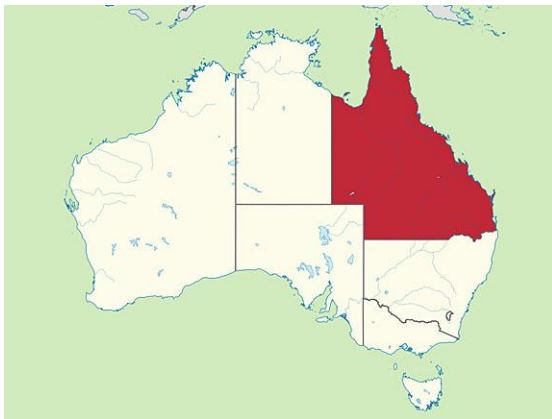
Classification of works in waterways

- **Low:** stream order 1 or 2, the change is for a short duration (< 2 years) or occurs when there is no flow in a waterway.
- **Medium:** activities occur in a medium stream order 3 to 4, the activity will cause a material change or alteration that is for a longer duration (> 2 years), or it may occur when there is water in a waterway.
- **High:** activities occur in a higher stream order 4 or more, the activity will cause an extensive material change or alteration, and occurs for a long duration.

Queensland – State Code 18 (2022)



Raising waterway barrier works, 2022



Queensland



Box culvert with baffles



Photo supplied by Catchments & Creeks Pty Ltd

Small rural bridge crossing

'State Development Assessment Provisions (SDAP) guideline'

State Code 18: *Constructing or raising waterway barrier works in fish habitats.*

The Department of Agriculture and Fisheries.
State of Queensland, 2022.

A Guide to Queensland Fisheries State Code 18

- A guide to the Code is provided in the Catchments & Creeks' field guide, '[A Guide to Queensland Fisheries State Code 18](#)' (2024)

Performance Outcome PO1

Waterway barrier works do not result in adverse impacts on waterways.

- Demonstrate no adverse impacts to waterways and fish habitats.
- Development footprint minimised.
- Minimise impacts to waterway habitats.
- Minimise change to local hydrology and hydraulics (note: the term 'hydrology' includes all aspects of hydraulics).

Performance Outcome PO2

Development is designed, constructed and maintained to avoid and minimise impacts on matters of state environmental significance.

- Demonstrate alternative structure placement and/or construction methods and/or timing are not practical.
- Construct a bridge rather than culverts.
- Simulate the hydrological and physical characteristics of the natural waterway.
- Culvert cells span 100% of the main channel width of a waterway.

Queensland



Fishway bypass around a fish barrier

Performance Outcome PO3

Where development impacts on matters of state environmental significance, development mitigates impacts and provides an offset for any acceptable significant residual impact on matters of state environmental significance.

- Incorporation of fishways.
- Use of fish-friendly structures.
- Retention and/or restoration of natural vegetation.
- Off-stream access for maintenance, and fencing to control stock access.



Drowned-out culvert structure

Acceptable Outcome: AO5.1

FOR ALL TYPES OF CROSSINGS

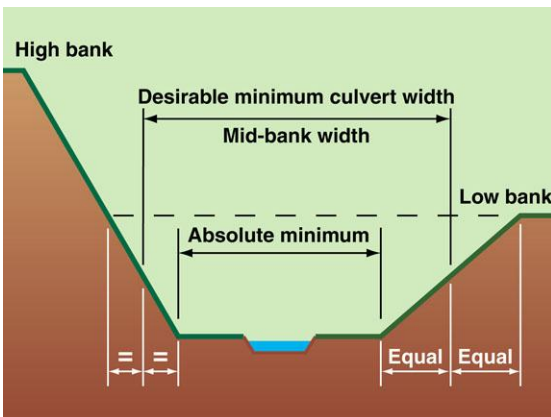
Hydraulic conditions (depth, velocities and turbulence) from the downstream to the upstream limit of the structure allow for fish passage of all fish attempting to move through the crossing at all flows up to the drownout of the structure.



Artificial culvert-bed roughness

Acceptable Outcome: AO5.4

The crossing and associated erosion protection structures are roughened throughout to approximately simulate natural bed conditions.



Desirable minimum culvert bed width

Acceptable Outcome: AO5.14

FOR CULVERTS ONLY

The combined width of the culvert cell apertures are equal to 100 percent of the main channel width.

Queensland



Introduced bed roughness

Acceptable Outcome: AO5.15

The base of the **culvert** incorporates a low flow channel consistent with the natural low flow channel and:

1. is buried a minimum of 300 mm to allow bed material to deposit and reform the natural bed on top of the culvert base; or
2. the base of the culvert is the waterway bed; or
3. the base of the culvert cell and any scour protection within the waterway is roughened throughout to approximately simulate natural bed conditions.



Sidewall baffles

Acceptable Outcome: AO5.16

FOR CULVERTS ONLY

The outermost culvert cells incorporate roughening elements such as baffles on their bankside sidewalls.

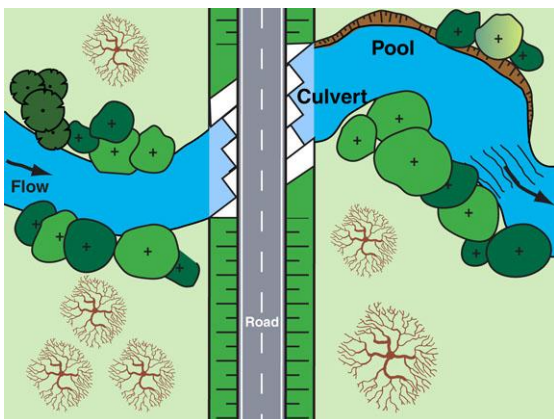


Wingwall baffles

Acceptable Outcome: AO5.17

FOR CULVERTS ONLY

Roughening elements are installed on the upstream wingwalls on both banks to the height of the upstream obvert or the full height of the wingwall.



Skewed culvert

Acceptable Outcome: AO5.19

FOR CULVERTS ONLY

Culvert alignment to the waterway flow minimises water turbulence.

Queensland

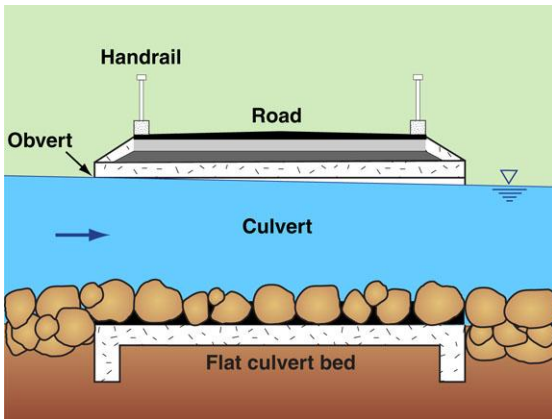


Roadbase cover over a box culvert

Acceptable Outcome: AO5.21

FOR CULVERTS ONLY

The depth of cover above the culvert is as low as structurally possible, except where culverts have an average recurrence interval (ARI) greater than 50 years.

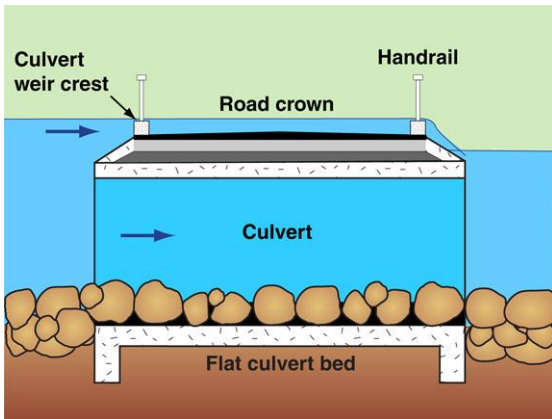


Culvert flowing 'full'

Acceptable Outcome: AO5.22

FOR CULVERTS ONLY

For culvert crossings designed with a flood immunity ARI greater than 50 years, fish passage is provided up to culvert capacity.



Overtopping flow condition

Performance Outcome PO8

The downturn characteristics of the waterway barrier works are designed and constructed to not result in adverse impacts to fish passage.



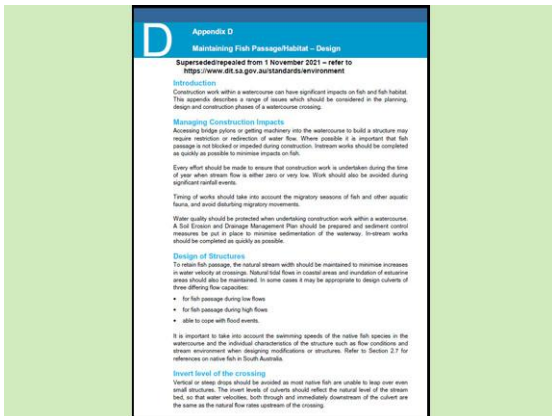
Photo supplied by Catchments & Creeks Pty Ltd

Placement of scour protection

Performance Outcome PO17

The development is designed, constructed and maintained to not result in adverse impacts to beds, banks and vegetation adjacent to the permanent development footprint

South Australia



Maintaining fish passage habitat, 2021



South Australia



Photo supplied by Catchments & Creeks Pty Ltd

Pipe culvert (Port Lincoln, SA)



Drop outlet (Brookman Rd, Meadows)

'Protecting Waterways Manual', App-D. Maintaining Fish Passage Habitat, 2021

- Appropriate positioning to ensure fish passage is possible.
- Scour pool protection and/or headwall protection to prevent erosion.
- Adequate culvert or pipe size.
- Correct positioning of culverts or pipes to maintain flow and prevent erosion or flooding.
- Suitable site selection (e.g. straight stream section).

Additional reference:

Watercourse crossings 2020 (Northern and Yorke Region)

- Expert advice should be sought if there is any evidence of groundwater issues, (e.g. waterlogging, or acid sulphate soils) or in instances where significant erosion is an issue.
- Cut-off drains to trap silt and sediment from road run off.
- Appropriate causeway or crossing height.

Construction impacts

- Where possible it is important that fish passage is not blocked or impeded during construction.
- Instream works should be completed as quickly as possible to minimise impacts.
- Program works during the time of year when stream flow is zero or very low.
- Take into account the migratory seasons of fish and other aquatic fauna.
- Water quality to be protected.

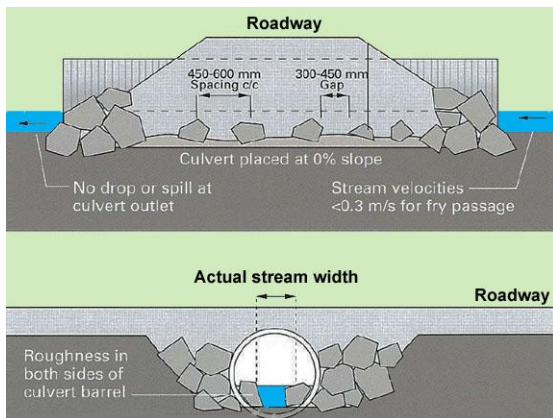
Design considerations

- In order to retain fish passage:
 - natural stream width should be maintained
 - natural tidal flows in coastal areas and inundation of estuarine areas to be maintained
 - consider fish passage needs during low flows, high flows, and flood events
 - avoid vertical or steep drops
 - culvert invert = natural invert
 - culvert velocity = natural velocity.

South Australia – Protecting Waterways Manual, Appendix-D



Floor baffle (Oodnadatta Track, SA)



Rock placement (from a USA document)



Photo supplied by Catchments & Creeks Pty Ltd

Deposition of sediments in a pipe culvert



Photo supplied by Catchments & Creeks Pty Ltd

Pre-cast bed roughness units

Managing a drop or apron

- 'If a drop needs to be created, provide resting places for fish on the downstream apron or a fish ladder.'
- 'Wooden baffles, boulders or large rocks can be successfully added to the downstream apron of a weir to provide resting areas.'
- 'The order of placement of obstruction objects is important and an ordered pattern of staggered rows suited to the size of fish in the waterway, should be used.'

Use of rocks

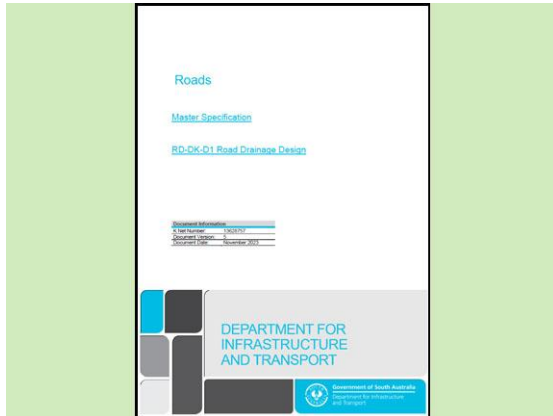
- 'If using rocks they should have crevices under them to provide access for fish to hide and rest.'
- 'The placement of jutting, irregular shaped and sized rocks immediately upstream and downstream of the culvert and on the apron of a structure or weir provides shelter and rest areas for fish entering and exiting the culvert.'

Diagram produced by: [Choctawhatchee Watershed Management Authority, 2000, Florida, USA.](#)

Improving habitat within a culvert

- 'Bottomless culverts/pipes ensure minimal disturbance to the stream bed.'
- 'The base of the pipe/culvert is set into, rather than on the stream bed.'
- 'Natural sediments from the site (e.g. mud, sand and gravel) can be placed on the bottom of the culvert which can then provide continuous stream bed habitat.'
- 'The top surface of the base of the culvert/pipe can be roughened at the concrete pouring stage to create small depressions—these will then allow natural sediments to be trapped in the base of the culvert/pipe creating a more natural substrate for fish or a fish passage can be built into the culvert base.'
- 'Pipes/culverts create a foreign environment which may be difficult for fish to negotiate and may even inhibit fish movement because of the dark conditions—in these situations consideration should be given to minimising the width of the structure, or incorporating grates, or skylights in the top of the culvert/pipe.'

South Australia – (Road Works)



RD-DK-D1 Road Drainage Design, 2023

Roads, Master Specification, RD-DK-D1 Road Drainage Design

- Department of Infrastructure and Transport, Adelaide, South Australia
- RD-DK-D1 Road Drainage Design
- K Net Number: 13628757
- Document Version: 5
- Document Date: November 2023.



AustRoads Guide to Road Design 5B

General

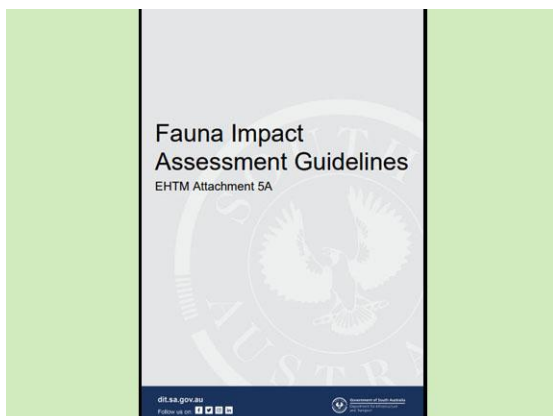
- Culvert requirements are set out in [Section 15](#) of this Master Specification Part.
- Section 1.3: Road drainage design must comply with the Reference Documents, including:
 - (e) **AGRD** Part 5B Drainage – Open Channels, Culverts and Floodway Crossings
 - (AGRD = AustRoads Guide to Road Design).



Fish in Torres River, Adelaide

Section 2 – Documentation

- Section 2.3 Design Report:
 - Fauna and fish passage assessment, design criteria, and details incorporated within the design.

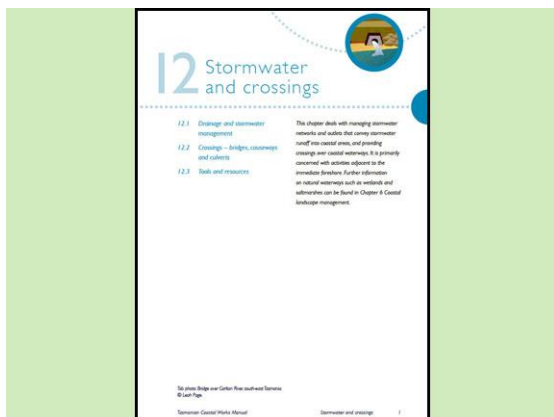


Fauna Impact Assessment Guidelines

Section 5 – Environment

- 5.13: Design of infrastructure that includes the alteration of natural watercourses must mitigate detrimental impacts to terrestrial and aquatic fauna passage.
- 5.14: Requirements for fauna and fish passage at culverts must be determined in conjunction with the Principal's Environment and Stormwater Groups.
- 5.15: Refer to the Department's environmental standards and guidelines, including Fauna Impact Assessment Guidelines.

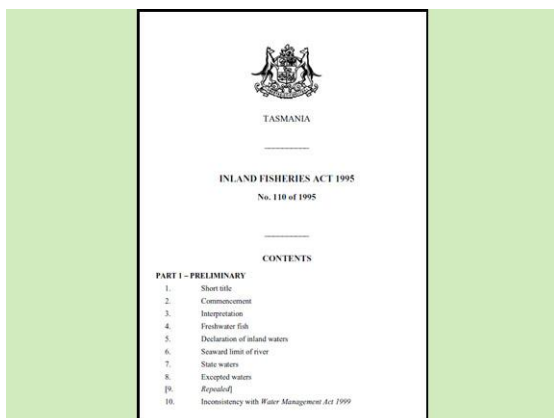
Tasmania



Stormwater and crossings, 2010



Tasmania



Inland Fisheries Act, 1995



Timber bridge near Montezuma Falls, Tas.

Tasmanian Coastal Works Manual - Ch12, 'Stormwater and crossings', 2010

Section 12.2: Crossings – bridges, causeways and culverts

- Culvert construction can cause significant bed and bank disturbance in waterways.
- Waterway crossings can create barriers to fish movement, as well as ongoing bank erosion.

The following text are not direct quotes, but instead are the author's interpretation of the printed text.

Aims

- The aims are to:
 - minimise impacts on coastal processes, values and ecosystems
 - maintain tidal flows
 - allow the passage of fish and other animals
 - present an attractive part of the landscape that could, where appropriate, serve as useful viewing points and fishing places.

12.2.1 Legislation and approvals

- Of particular relevance to crossings is the *Inland Fisheries Act 1995*, which prevents the obstruction of fish passage.
- Structures below high water mark also require DPIPWE Crown Land Services approval and a Crown Land lease.
- Depending on the structure's size and nature, DPIPWE may require submission of a *Development Proposal and Environmental Impact Statement*.

12.2.2 Types of crossings

- The type of waterway crossing should cause the least amount of environmental damage.
- Preferences are first: bridge, then arch, open-bottom box culvert, closed-bottom box culvert, and finally, pipe culvert.
- Culverts should be fully embedded in the stream bed, and ideally should have an artificial substrate provided down the mid-line of the pipe (e.g. cemented rocky gravel).

Tasmania – Waterway crossings in coastal environments



Photo supplied by Catchments & Creeks Pty Ltd

Site planning



Photo supplied by Catchments & Creeks Pty Ltd

Natural sediment flow



Photo supplied by Catchments & Creeks Pty Ltd

Culvert construction during low flows

Section 12.2.4 – Planning for crossings in coastal environments

- Seek specialist advice about fauna, flora and aquatic values in the area.
- Design crossings to accommodate requirements of threatened and/or highly valued species.
- Schedule works to avoid disturbance to sensitive species such as shorebirds.
- Consider temporary relocation of threatened species if appropriate.

Location of waterway crossings

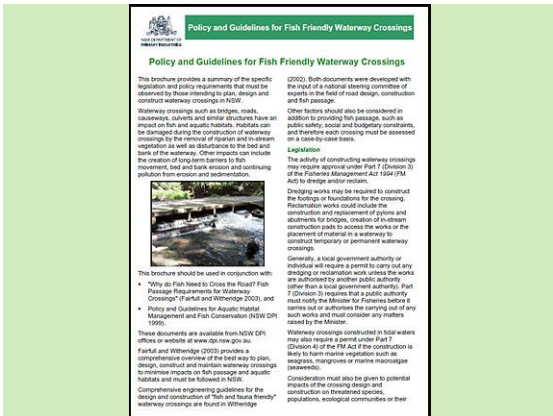
- Align structures perpendicular to the direction/s of the prevailing waves and sediment movement, wherever possible.
- Aim to minimise obstruction to the natural movement of sand/sediment.
- Preserve the connectivity of the waterway by minimising any constriction of water flow, thus simulating natural channels and water flows.

Timing of works

- Plan works in watercourses and estuaries to coincide with low water flows, unless this may have adverse effects on plant communities and animals (especially threatened aquatic, estuarine and marine species).

Design issues

- Design structures and time the works to minimise disturbance to the passage of fish and other aquatic fauna.
- Provide enough space under the bridge for animals to walk along the riverbanks, where practicable.
- Seek specialist advice and refer to the design considerations in the *Policy and Guidelines for Fish Friendly Waterway Crossings* (NSW Department of Primary Industries).



NSW fish friendly waterway crossings

Tasmania – Waterway crossings in coastal environments



Tasmania Inland Fisheries Service



Photo supplied by Catchments & Creeks Pty Ltd

Erosion by overtopping flows



Photo supplied by Catchments & Creeks Pty Ltd

Arched bridge

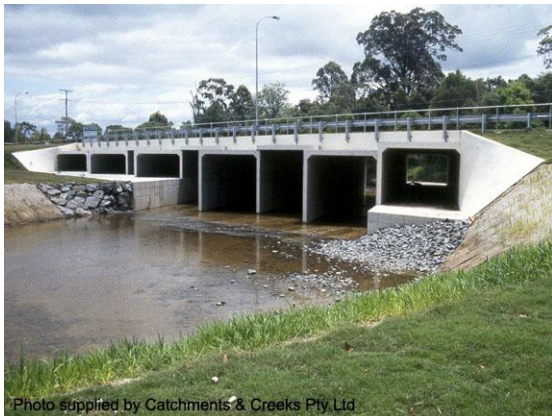


Photo supplied by Catchments & Creeks Pty Ltd

Multi-cell box culvert with wet & dry cells

Section 12.2.7 – Culverts

- If fish are likely to be present, consult a specialist and seek technical information on culvert design and placement.
- Consult the [Inland Fisheries Service](#) to ensure the passage of fish will be provided for appropriately.
- The [Forest Practices Code](#) (Forest Practices Board 2000) has design and installation requirements to assist the passage of aquatic freshwater fauna, some of which will apply to estuarine species as well.

Flow capacity

- Ensure the culvert's capacity can accommodate peak flow volumes, so that the top of the inlet is:
 - not submerged in peak flows by more than 0.5 m (in low to moderate-high erodibility class soils), or
 - 0.1 m (in high to very high erodibility class soils)
 - unless measures are used to protect against erosion where the water discharges at the downstream end.

Arched structures

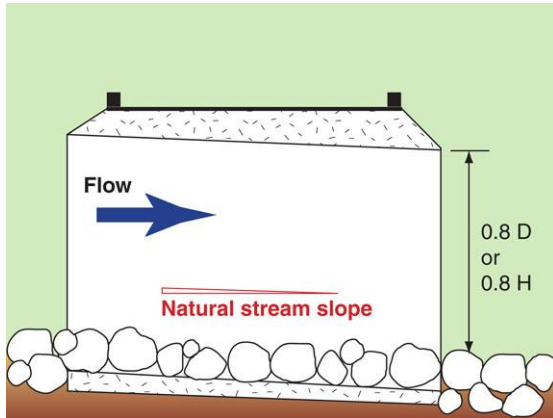
- Open-bottom culverts, with the natural streambed running through them, are preferable to other culverts.
- Ensure they do not break up the streambed material, and are large enough not to constrict flows, or trap debris during normal flow conditions.

Author's note: By definition, a culvert is a fully enclosed conduit, not an open-bottom conduit. An arched structure is a 'bridge', not a culvert. A pre-cast box culvert installed without a foundation is an unstable structure.

Culverts

- If an open-bottom culvert is not suitable, then one large culvert spanning the width of the waterway is preferable to two or more small culverts.
- If multiple culverts are needed to span the riverbed, one or more cells should be slightly lower than the others to concentrate low flows, and allow fish to swim through.

Tasmania – Waterway crossings in coastal environments



Catchments and Creeks diagram

Culvert bed slope

- Ensure the culvert gradient is gently sloping, similar to the stream gradient.
- To allow fish passage, avoid using culverts on a waterway with a gradient of more than 2% (1:50).
- The gradient immediately downstream of the culvert should be less than 5% (1:20), so fish can approach the culvert outlet.



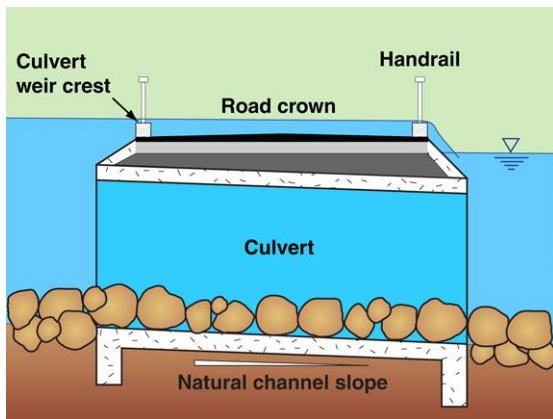
Photo supplied by Catchments & Creeks Pty Ltd

Poor lighting conditions

Avoid excessively dark culverts

- Ensure the culvert has at least 600 mm of space above the typical base flows (low flows of the stream), so that it is light enough inside to encourage fish to enter and swim through.
- The minimum diameter of culvert pipes should be 300 mm (or 375 mm in areas with high or very high erodibility class soils, where the risk of culvert blockage or failure is high).

Author's note: Unsure how a 300 mm pipe can have 600 mm headroom?



Overtopping flow conditions

Flow conditions

- Ensure that water velocities in the culvert are similar to those at the site before the culvert was constructed.
- There should also be no differences in the flow rates upstream, inside the culvert, and downstream.

Author's note: The term 'flow rate' relates to 'discharge' (i.e. the term 'rate'). In general, the flow rate upstream, inside, and downstream of a culvert is always equivalent, except when the culvert is being overtopped.



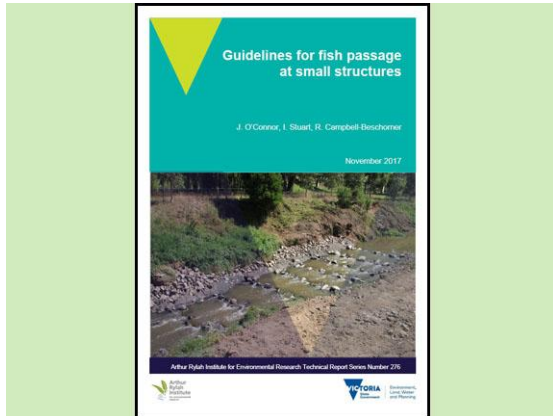
Photo supplied by Catchments & Creeks Pty Ltd

Introduced bed roughness rocks

Bed roughness

- Concrete baffles or large angular rocks (typical of the area) along the base of longer concrete culverts will reduce flow velocities and allow aquatic animals to pass through.
- Lining the base of the culvert with a rough concrete finish and/or natural substrate will increase turbulence and make it easier for fish to swim through.
- Velocities of less than 0.3 m per second will allow most native fish to swim through a 5 m long culvert.

Victoria – Guidelines for fish passage at small structures, 2017



Fish passage at small structures, 2017



Victoria



Murray Cod



Victorian Government, 2017

'Guidelines for fish passage at small structures', 2017

- O'Connor, J., Stuart, I. and Campbell-Beschoner, R. (November, 2017).
- Arthur Rylah Institute for Environmental Research. Technical Report Series No. 276.
- Department of Environment, Land, Water and Planning, Heidelberg, Victoria.
- ISSN 978-1-76047-237-5 (print).
- ISSN 978-1-76047-238-2 (pdf).

Legislation (as of 2017)

- Fish passage is protected by:
 - *Water Act 1989*
 - *Fisheries Act 1995*
 - *Flora and Fauna Guarantee Act 1988*
 - *Conservation, Forests and Lands Act 1987*
 - various policies of the Catchment Management Authority (CMA) Regional Catchment Strategies.

Fish passage objectives,

- The fish passage objectives, may include:
 - pass all fish species present downstream of the structure
 - pass fish of size range 40–700 mm
 - provide fish passage for the full range of the headwater levels, tailwater levels, and stream discharges within which fish migrate
 - provide fish passage in both upstream and downstream directions.

Remediation options for culverts

- There are numerous rehabilitation options for culverts, including:
 - removal
 - replacement
 - modification
 - adding roughness to culverts
 - drowning out existing culverts
 - adding extra culvert barrels or upsizing existing ones.

Victoria – O'Connor (2017) – Generic culvert optimisation design features



Rejection of design feature

Maximum flow velocity

- 'Culverts should have a maximum 0.3 m/s water velocity (i.e. < 10 mm head loss) for passage of small fish.'

Author's note: In my opinion, this design condition represents a gross misunderstanding of culvert fish passage.

Fish-friendly culverts can have flow velocities much greater than 0.3 m/s!

Fish-friendly culverts can have a head loss much greater than 10 mm!



Oh dear!

Flow area

- 'The cross-sectional area should more than match the stream width.'

Author's note: An 'area' requirement cannot be compared to a 'width' condition.

- 'Often larger culverts (e.g. minimum culvert size of 1.5 m square) provide a greater cross-sectional area than smaller culverts . . .'

Author's note: Larger culverts are always greater in area than smaller culverts!



Thinking

- 'Culverts should maintain the natural stream depth and be 1.25 times the cross-sectional area of the stream (i.e. install more culverts rather than less).'

Author's note: This condition is not necessary in order to achieve a fish-friendly culvert.

- Avoid water constrictions (and subsequent high water velocities) at the culvert.

Author's note: The focus should be on boundary conditions, not the average flow velocity.



Agreement

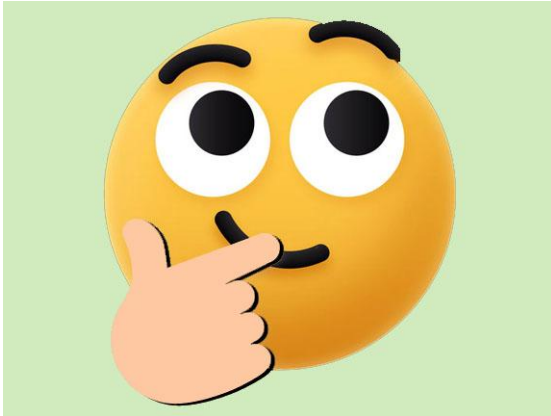
Lighting conditions inside the culvert

- 'Culverts which enable good light penetration and have water 'freeboard' are preferred—that is, the obvert (roof) of the culvert is usually dry.'

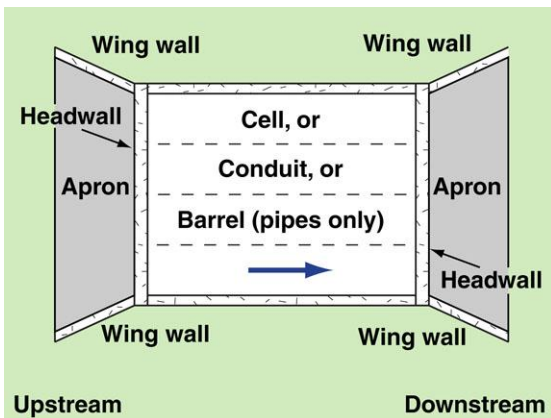
Author's note: Providing good light penetration is desirable.

Author's note: The obvert of most culverts, including non-fish-friendly culverts, is usually dry!

Victoria – O'Connor (2017) – Generic culvert optimisation design features



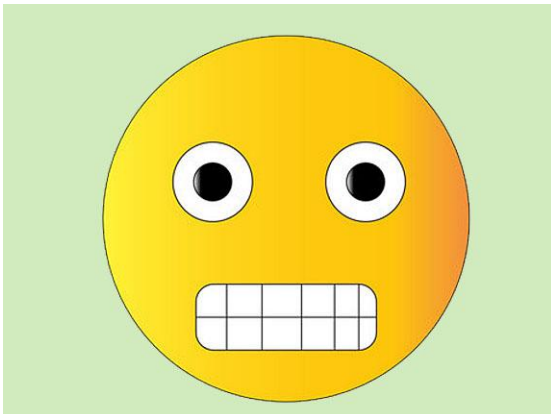
Thinking



Culvert terminology



Thinking



Be careful

Culvert geometry

- 'Generally box or arched culverts provide greater fish passage opportunities than pipes.'
- 'A minimum depth of 0.3 m should be provided for small and medium fish.'
- 'Generally culvert length should not exceed 6 m.'

Author's note: A maximum culvert length of 6 metres is unrealistic for road culverts.

- 'Scouring and perching at the entrance or exit of the culvert should be avoided.'

Wingwalls

- 'Headwalls, tailwalls or wingwalls should not be diagonal, as this produces poor hydraulics for fish passage.'

Author's note: I believe this clause is confusing these engineering terms, especially given that the intended audience is engineers.

- 'Perpendicular walls at 90° to the culvert are preferred.'

Author's note: I know of no basis for this claim.

Bed slope

- 'Culverts should be installed with no slope (or match the bed gradient where the culvert is counter-sunk).'
- 'The culvert (including the entrance and exit) should be counter-sunk (c. 30 cm) into the stream bed, thus enabling bed material to build up and avoiding any artificial gradient.'

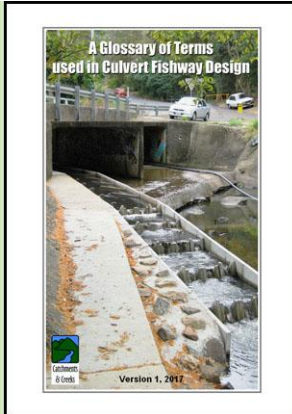
Author's note: If a culvert is counter-sunk, then its bed slope is irrelevant to fish passage.

Tailwater controls

- 'A 0.5 m high, downstream sloped (30°) water retention end-sill (usually concrete) can be considered for raising the tailwater, thereby reducing turbulence and providing a refuge/plunge pool.'
- 'This design feature is especially relevant for wetlands that are regularly dried in perennial systems.'

Author's note: I find this design condition to be very concerning, and likely to result in the formation of a future fish passage barrier.

Victoria – O'Connor (2017) – Culvert baffle design criteria



Glossary of Terms Used in Fish Passage



Thinking



Oh dear!



Sad face

Location of baffles

- 'Baffles usually need only be applied on each river bank; that is, one row of baffles for the culverts to simulate continuation of the bank roughness.'
- 'For single culverts, baffles on both side walls are recommended.'
- 'The baffles must continue along any wingwalls, headwalls or tailwalls (at least two baffles).'

Author's note: Misuse of terms: headwall and tailwall ('tailwall' is not an engineering term).

Geometry

- 'Baffles should be 100 mm wide, i.e. protrude 100 mm into culvert and can be made from galvanised iron, stainless steel or aluminium.'

Author's note: Why should baffles be restricted to these materials?

- 'The gauge of the angle should be 10 mm.'
- 'The baffles should be at least 95% of the full height of the culvert from invert to obvert.'

Baffle spacing

- 'The baffle spacing should be 400 mm within the culvert (i.e. 4 x baffle width) but at the top and bottom 2 m of the culvert the spacing should be 200 mm (i.e. 2 x baffle width).'

Author's notes: Misuse of the terms: 'top' and 'bottom' of a culvert.

Correct terminology is; upstream and downstream ends of the culvert.

'Top' means the obvert.

'Bottom' means the floor or invert.

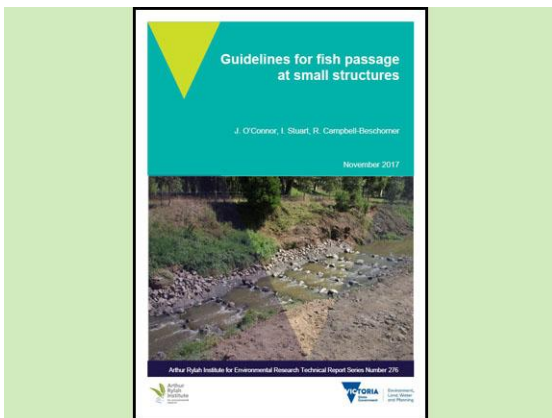
Final note from the author

- If the Victorian government would like to avoid presenting questionable engineering recommendations in the future, then maybe they can encourage greater engineering input into the drafting of engineering guidelines.
- It is just as important to have a mixture of professions involved in the production of codes and guidelines as it is to have a mixture of professions involved in the design of a culvert.

Victoria – Justification for my comments



Explanation



O'Connor Stuart & Campbell-Beschoner

Table 3.1: Headloss, water velocity and minimum fish sizes that might negotiate a culvert (from Mallen-Cooper 2001).

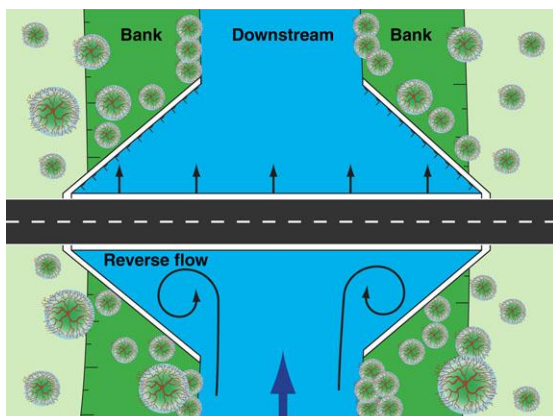
Headloss (mm)	Max. water velocity (m/s)	Fish length (mm)	Comment
2	0.15	< 80	Design standard for wetlands
10	0.3	> 100	
20	0.45	> 150	
50	0.75	> 250	
80	0.93	(> 400)	
100	1.05	(> 500)	

Generic culvert optimisation design features to improve fish passage should include the following design elements:

- culverts should have a maximum 0.3 m/s water velocity (i.e. < 10 mm headloss) for passage of small fish.
- generally box or arched culverts provide greater fish passage opportunities than pipes.
- Culverts which enable good light penetration and have water 'freeboard' are preferred. That is, the overtop of the culvert is usually dry.
- the cross-sectional area should more than match the stream width. Often larger culverts (e.g. minimum culvert size of 1.5 m square) provide a greater cross-sectional area than smaller culverts, and thus a reduced flow velocity that improves fish passage.
- culverts should be installed with no slope (or match the bed gradient where the culvert is counter-sunk).

12 Guidelines for fish passage at small structures

Table 3.1 & notes (O'Connor, et.al., 2017)



Culvert wider than the waterway channel

Introduction

- I just presented some rather negative feedback on one particular Victorian Government document.
- I also suggested that the quality of these government documents could be improved through the inclusion of some engineering feedback.
- But let me make it perfectly clear, I do not question the expertise of the authors, I am only suggesting that additional expertise needs to be added to the drafting and/or review teams.

Potential engineering input

- Let us go back to the document's first recommendation:

'Culverts should have a maximum 0.3 m/s water velocity (i.e. < 10 mm head loss) for passage of small fish. (O'Connor, Stuart, and Campbell-Beschoner, 2017, page 12)'

- When a creek or river is flowing bankfull during a flood event, the average velocity in the channel is typically 2 to 3 m/s.
- I know this because I used to monitor water velocities in rivers during the early period of my career. We often detected flood velocities over 5 m/s in the centre of rivers.

- If we assume the natural, average, bankfull velocity is 2 m/s, and we require a maximum 0.3 m/s water velocity in a culvert, then the culvert must have a cross-sectional area that is over 6 times the channel's cross-sectional area.

- That means, the culvert needs to be 670% larger than the channel within which it is located!

- This, of course, also means that the culvert's wingwall cannot possibly be 'perpendicular walls at 90° to the culvert'.

- Now, if we accept these flow velocities, then the head loss (ΔH) at a culvert can be approximated by:

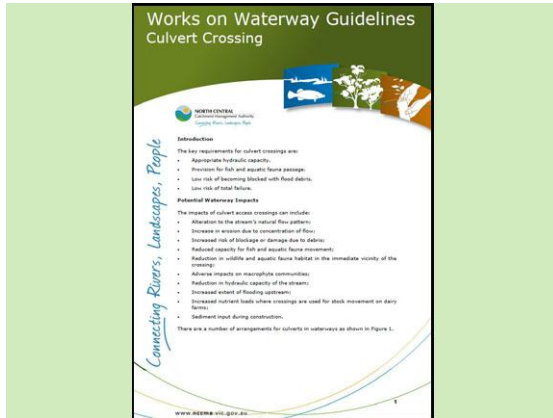
$$\Delta H \approx 1.5(2^2/2g - 0.3^2/2g) + 0.2(0.3^2/2g)$$

- We find that the culvert's head loss would approximately be:

$$\Delta H \approx 300 \text{ mm}$$

- So, the specified velocity objective would result in a head loss that is 30 times greater than the specified head loss objective.
- Meaning that a hydraulics engineer should have had input into the drafting of these culvert design objectives.

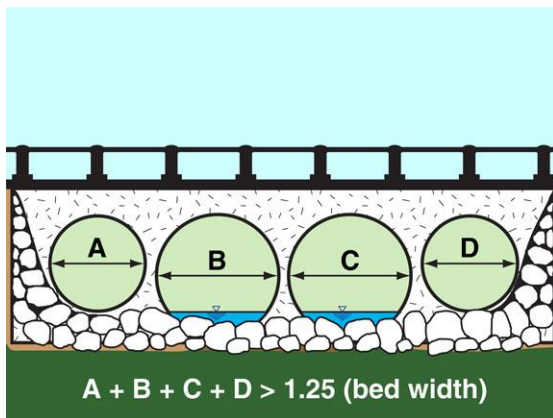
Victoria – Works on Waterway Guidelines - Culvert Crossing, 2019



Works on Waterway Guidelines, 2019

'Works on Waterway Guidelines - Culvert Crossing', 2019

- Peter O'Toole, North Central Catchment Management Authority.



Suggested culvert width

Culvert width

- 'For Class 2 streams the recommended width of the box culverts across the bed is 125% of the typical stream bed width.'
- 'For pipe culverts on Class 4 streams, the total pipe diameter should be equal to the base stream bed width.'
- 'This approach ensures close to natural stream velocities are maintained for aquatic fauna, and minimises the potential for bed erosion.'

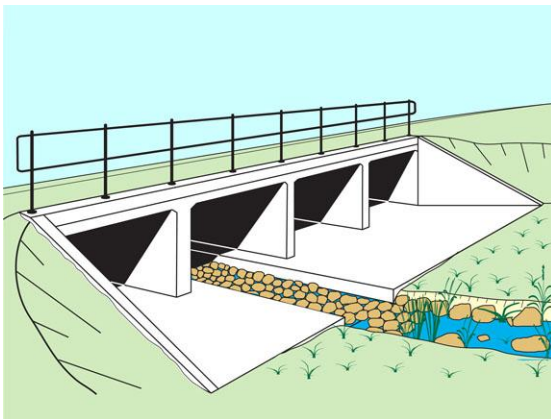
Table A2 – Minimum preferred structures for fish passage (from above fact sheet)

Stream classification	Stream characteristics	Preferred structure type
Class 1 - Major fish habitat	Large named permanently flowing stream. Aquatic vegetation present. Known fish habitat.	Bridge
Class 2 – Moderate fish habitat	Smaller named permanently or intermittent flowing stream. Aquatic vegetation present. Known fish habitat.	Bridge or large box culvert
Class 3 – Minimal fish habitat	Named or unnamed watercourse with intermittent flow.	Bridge or box culvert
Class 4 – Unlikely fish habitat	Named or unnamed stream with flow during rain events only.	Bridge, ford, box culvert or pipe culvert

Victoria – Works on Waterway Guidelines - Culvert Crossing, 2019



Example of a skylight ('light grid')



Recessed low-flow channel



Installation of a long pipe culvert



Overtopping flood event

Culvert length

- 'Generally culvert length should not exceed 6 metres.'

Author's note: Unrealistic for most road culverts. Also, unsure why this should apply if appropriate in-barrel features are added to the culvert.

- 'Culverts can also include light grids to allow sufficient light through the culvert so that native fish species are not discouraged by a sudden decrease in light levels.'

Invert level

- 'The invert of the culverts should be at least 300 mm below the bed of the stream.'
- 'This will avoid any artificial gradient and allow some sedimentation to occur within the culvert, thus providing a more natural environment for fish and aquatic fauna.'

Author's note: Unsure if this rule applies to just the structure's invert, or the invert of each cell (conduit). If the latter, then this could conflict with terrestrial passage recommendations.

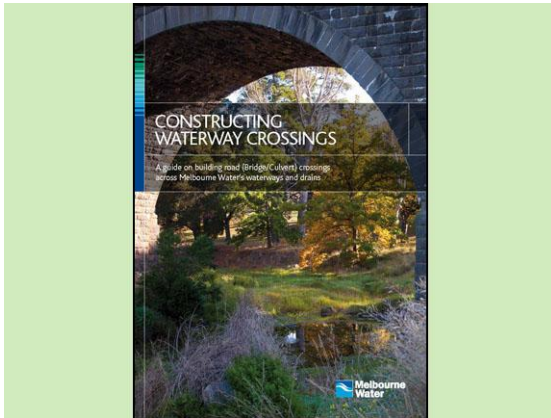
Culvert height

- 'A minimum culvert height of 1200 mm is recommended for low level culvert crossings on Class 2 streams.'
- 'A lesser height of 900 mm would be acceptable for Class 3 and 4 streams.'
- 'This is based on providing at least 600mm airspace above the typical base flow in the stream to ensure reasonable light within the culvert to encourage fish passage, as well as capacity for minor flows.'

Embankment stabilisation

- 'Rock size should be determined based on the critical flow over the crest before the structure becomes drowned out.'
- 'The road embankment compacted to achieve 95% maximum dry density.'
- 'Well graded hard quarried rock placed 1.5 to 2 times the rock size in thickness.'
- 'Minimum D_{50} of 300 mm.'
- 'Downstream embankment batter to have a maximum slope of 1(v):4(h).'

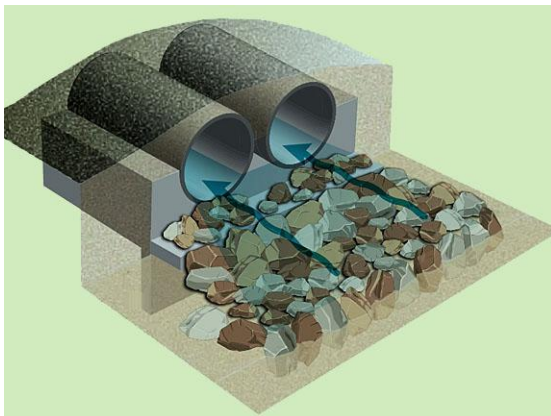
Victoria – Melbourne Water, Constructing Waterway Crossings, 2011



Melbourne Water - Waterway crossings

'Constructing Waterway Crossings', 2011

- A guide on building road (Bridge/Culvert) crossings across Melbourne Water's waterways and drains.
- Melbourne Water, 100 Wellington Parade, East Melbourne, Victoria.
- ISBN 978-1-921911-11-8 (print)
- ISBN 978-1-921911-12-5 (web)



Inlet and outlet scour protection

Minimum hydraulic capacity

- The pipe sizing must meet the 1 in 10 ARI or capacity of creek. (Author: the 'capacity of creek' is assumed to mean the bankfull flow rate.)
- Also the safety criteria for overtopping flows:
 - depth: $D \leq 0.35$ m
 - velocity: $V \leq 1.5$ m/s
 - $d.V$ product ≤ 0.35 m²/s.
- Minimum 1200 mm for pipe culvert.



Fish-friendly, multi-cell box culvert

Fish passage

- Culvert crossings should make allowance for fish migration through a barrier.
- Refer to '[Fish Passage through Culverts](#)' in Section 3.3.19 of DSE's 'Technical Guidelines for Waterway Management, Melbourne Water's Constructed Waterways in Urban Development Guidelines'.



Stock crossing (Melbourne Water)

Work permits

- A legally binding agreement must be entered into between Melbourne Water and the asset owner for liability and maintenance purposes.
- A Permit to Work can only be issued subject to the contractor performing Melbourne Water's recipient training.
- Contact Melbourne Water's Asset Services Team to arrange training, providing at least 21 days notice.

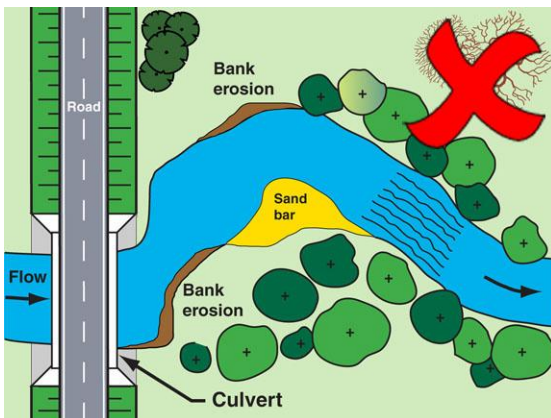
Victoria – Fauna Sensitive Road Design Guidelines, 2012



VicRoads, 2012

'Fauna sensitive road design guidelines'

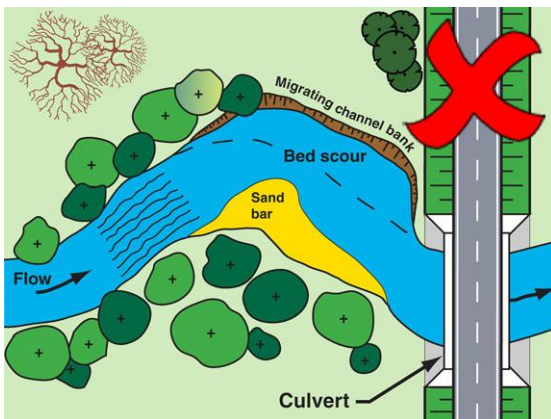
- VicRoads, 60 Denmark Street, Kew, Victoria, 2012
- Revision 0 / August 2012
- Document ID: 1447218
- Victoria State Government.



Culvert located upstream of sharp bend

Location of culvert

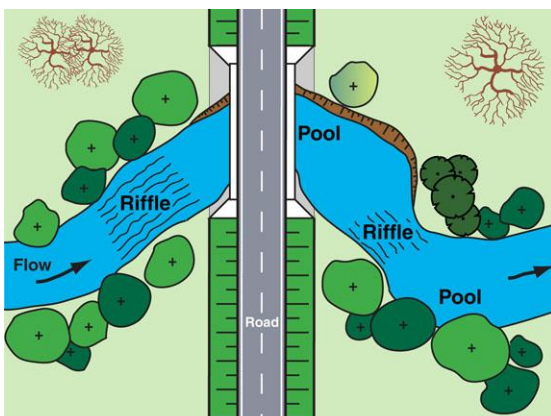
- 'Avoid crossing waterways near sharp bends, sections of unstable banks or naturally strong "riffle" systems.'
- 'Riffles are shallow rocky shoals or sandbars lying just below the surface of the waterway.'
- 'These areas act as natural important bank stabilisers and often provide essential habitat pools.'
- 'Any alteration of these systems may impact habitat, change bank stability and potentially initiate severe riparian erosion.'



Meandering upstream channel

Meandering channels

- 'Avoid locating crossing in areas where the river is likely to continue meandering into the future.'
- 'Meandering rivers cause maintenance headaches as changing waterways can damage structures such as culverts.'
- 'Future misalignment of the channel crossing may result from natural reshaping, rendering culvert and aquatic mitigation structures pointless.'



Culvert located at a natural pool

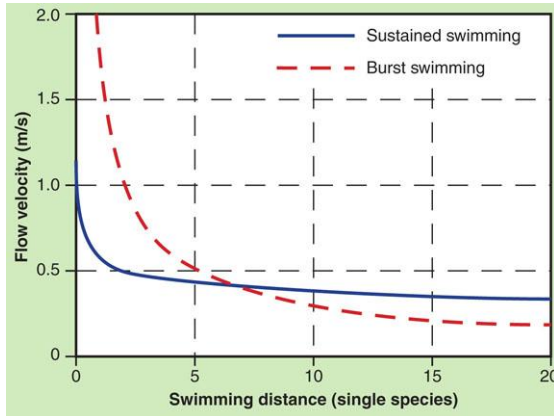
Identify and avoid natural habitat features

- 'Avoid works that change the frequency and spacing of existing natural habitat pools and riffle systems.'

Author's note: Culverts are better located at natural pools, rather than at natural riffles; however, pools are often located at channel bends, which can cause problems.

- 'Avoid the removal of essential shade trees, especially in areas which have already lost a lot of natural vegetation cover.'

Victoria – Fauna Sensitive Road Design Guidelines, 2012



Burst speed and sustained speed

Culvert flow area

- 'Culverts that are not as wide as natural stream beds restrict water flow and therefore increase water velocity.'
- 'This is detrimental to fish passage as a majority of fish cannot maintain strong burst speeds for long enough to swim to the other side of the culvert if the distance is too great.'

Author's note: Most road culverts are simply too long for fish to use continuous burst speed; hence, the need for resting zones within a culvert.

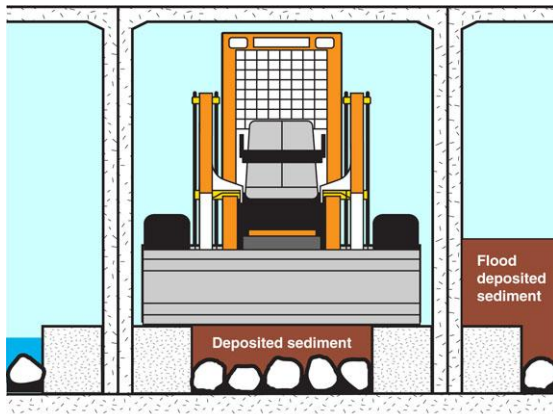


Photo supplied by Catchments & Creeks Pty Ltd

Long, dark culvert

Culvert size and length

- 'Small culverts are dark and easily get blocked with debris, blocking aquatic species movements.'
- 'Ideally, culverts should be less than six meters long especially when no resting areas are available and given that water velocity is likely to increase after the construction of new structures.'



Post-flood culvert maintenance

Culvert size

- 'Maximise natural light by making the dimensions of culverts as large as possible.'
- 'Large diameter culverts provide easy access and are easier to maintain.'
- 'Also, the wider the culvert the easier it is to maintain natural flows.'



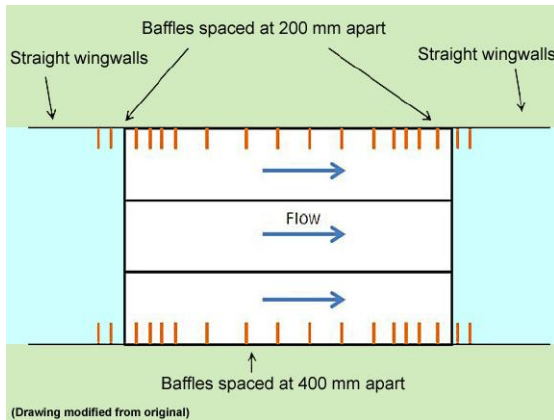
Photo supplied by Catchments & Creeks Pty Ltd

Sidewall baffles

Baffles

- 'Consider installing baffles on one or both sides of the culvert.'
- 'Baffles are appropriate for new culvert designs and projects should seek expert advice to ensure correct placement.'
- Baffles change the flow pattern in the vicinity of the culvert, creating zones of fast and slow moving water zones (modified text).
- 'This allows fish to use short bursts of energy while allowing periods of rest.'

Victoria – Fauna Sensitive Road Design Guidelines, 2012



Victorian Government, 2017

Location of baffles within a multi-cell culvert

- 'For multiple parallel culverts, only those fitted near stream beds should be fitted with baffles.'



Victorian Government, 2017

Culvert rehabilitation

- 'Upstream modifications to improve flow into culverts by raising low flow water levels within culverts.'
- 'Where high flow velocity is a concern, baffles could be installed.'
- 'This would change flow regimes, and provide various slow and fast water zones.'
- 'Upstream channel modifications could remove the issues associated with deep drops, or excessively steep rock ramps.'



Post-flood inspection

Culvert maintenance

- 'Maintenance requirements for aquatic culverts include:
 - controlling silt build-up and undertaking inspections annually as a minimum
 - ensuring vegetation and weeds don't become established at entrances to culverts.'
- 'As a minimum, maintenance should be ongoing and occur annually.'

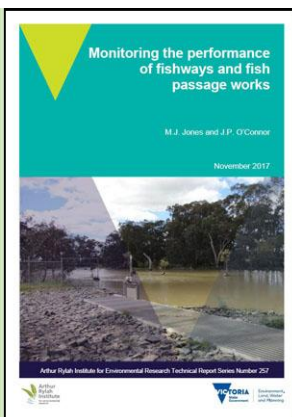


Introduced bed roughness rock

Substrate

- 'The substrate should be as natural as possible and incorporate a wide range of furniture including; large rocks, deep pools and fine gravel.'
- 'Where possible, consider using a three sided culvert with no base.'
- 'This maintains a natural streambed instead of hard concrete base and is more attractive to some species such as water invertebrates, fish, crustaceans and platypus.'
- 'Furniture must not adversely impede water flow, but can be considered in culverts where water velocity is a problem.'

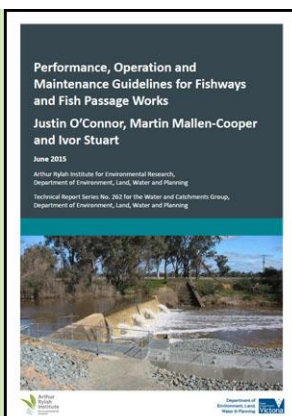
Victoria – Related fish passage research documents



Arthur Rylah Institute TR No. 257

'Monitoring the performance of fishways and fish passage works', 2017

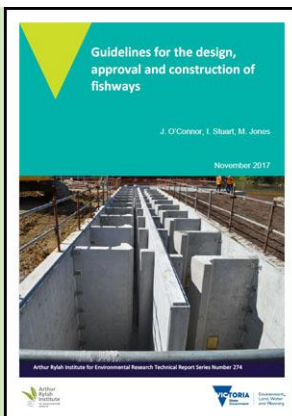
- Jones, M.J. and O'Connor, J.P. (2017).
- Arthur Rylah Institute for Environmental Research. Technical Report Series No. 257.
- Department of Environment, Land, Water and Planning, Heidelberg, Victoria.



Arthur Rylah Institute TR No. 262

'Performance, Operation and Maintenance Guidelines for Fishways and Fish Passage Works', 2015

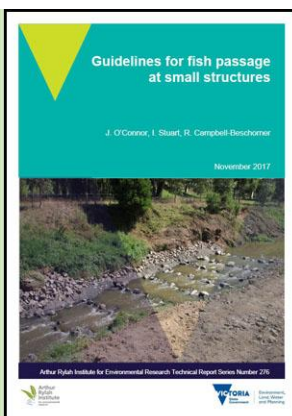
- O'Connor, J., Mallen-Cooper, M. and Stuart, I.
- Arthur Rylah Institute for Environmental Research. Technical Report Series No. 262.
- Department of Environment, Land, Water and Planning, Heidelberg, Victoria.



Arthur Rylah Institute TR No. 274

'Guidelines for the design, approval and construction of fishways', 2017

- O'Connor, J., Stuart, I. and Jones, M. (2017).
- Arthur Rylah Institute for Environmental Research. Technical Report Series No. 274.
- Department of Environment, Land, Water and Planning, Heidelberg, Victoria.



Arthur Rylah Institute TR No. 276

'Guidelines for fish passage at small structures', 2017

- O'Connor, J., Stuart, I. and Campbell-Beschorner, R. (November, 2017).
- Arthur Rylah Institute for Environmental Research. Technical Report Series No. 276.
- Department of Environment, Land, Water and Planning, Heidelberg, Victoria.

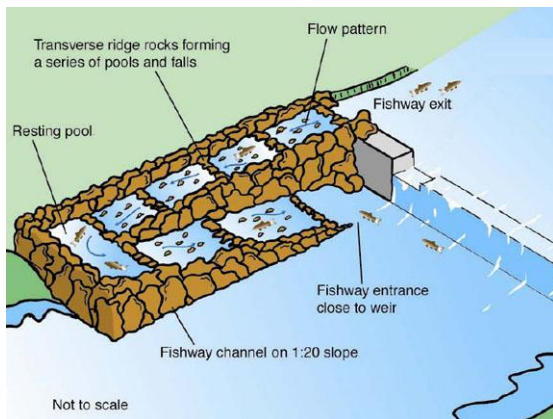
Western Australia – Reconnecting off-channel habitats to waterways



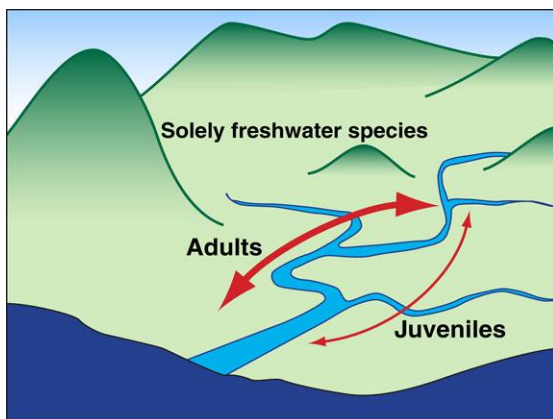
Reconnecting off-channel habitats, 2007



Western Australia



Rock ramp linked to weir headwall



Potential fish passage movement

'Reconnecting off-channel habitats to waterways – using engineering techniques to restore fish passage', 2007

- Paper for the proceedings of WA Wetland Management Conference, 2 February 2007, Cockburn Wetland Education Centre, 184 Hope Road Bibra Lake.
- Chrystal King (Department of Water), and Antonietta Torre (Department of Water).

Western Australia fish species

- 'Native freshwater fish in the south-west of Western Australia are relatively small in size (most ranging between 50 – 190 mm in length) . . .'
- Consequently they have limited swimming ability compared to some eastern states and overseas fishes (modified text).
- 'They are unable to negotiate steps higher than approximately 100 mm.'

Rock ramps

- 'A gradient of 1:20 should be applied to allow native fish to swim up the fishway steps.'
- 'Fish need an [attracting] flow to enter a fishway.'
- 'If connection to an off-channel habitat was proposed, the fishway would need to be constructed so that it was not detrimentally draining the off-channel habitat.'

Types of fish movement

- 'Downstream passage, and passage back into the main waterway, needs to be considered.'
- 'The fishway must not permit the spread of feral fish species to new habitats.'

Author's note: Controlling the movement of feral species is a difficult task requiring the input of experts. Designers should negotiate with Fisheries in order to achieve the greater good.

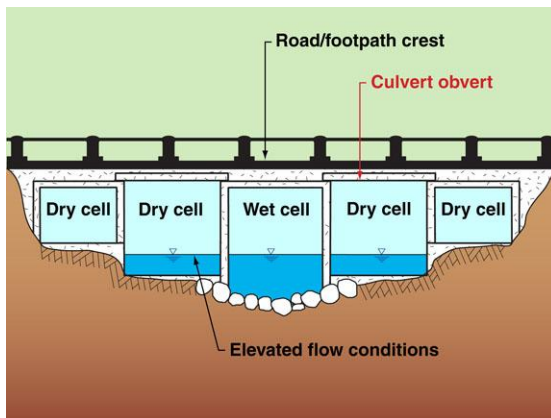
Western Australia – Reconnecting off-channel habitats to waterways



Apex Weir Fishway, Margaret River, WA

Case Study: Apex Weir Fishway, Margaret River

- 'A series of twenty 0.1 m high step pools to assist fish over the 2 m weir.'
- 'Approximately 40 m long.'
- 'The first ramp extends 26 m downstream from the weir wall, enters a turn-around pool, and a second flight extends 14 m back towards the weir wall.'
- 'The entry had to be located near the weir wall as fish are attracted to the main flow over the weir.'



Variable invert box culvert

Culvert flow area

- 'The crossings should maintain the cross-sectional area of the channels and endeavour to retain the hydraulic characteristics of the area, such that similar water volumes and velocities are maintained.'
- 'Pipe culverts are not recommended due to jetting effects.'
- 'Multi-celled box culverts are preferred to re-create the cross-sectional size and shape of the channel.'



Photo supplied by Catchments & Creeks Pty Ltd

Introduced bed roughness rock

Bed and sidewall roughness

- 'At least one culvert should be set below bed level to allow sediment to accumulate and create a more natural environment for aquatic fauna.'
- 'Alternatively the base can be roughened, or baffles or boulders inserted, to break up the flow within the culvert.'
- 'This will reduce the laminar flow and allow spaces for fish and aquatic fauna to rest.'

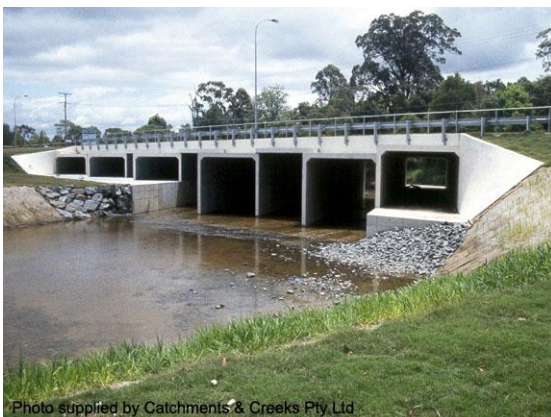


Photo supplied by Catchments & Creeks Pty Ltd

Multi-cell box culvert

Aquatic and terrestrial passage

- 'The culvert selected for [terrestrial] passage should be located nearest to the riverbank, not in the centre of the channel, as fauna tend to move along the sheltered zone adjacent to fringing vegetation.'
- 'There should be adequate depth of flow through the culvert during periods of fish migration.'
- 'Generally, a minimum water depth of 100 mm is recommended inside the culvert to allow passage for most south-west freshwater species.'

Western Australia – Reconnecting off-channel habitats to waterways



Photo supplied by Catchments & Creeks Pty Ltd

Skylight grid installed into the road kerb

Entry of natural light into the culvert

- 'Culverts should aim to let in as much light as possible.'
- 'Skylights can be installed along long culverts to increase the amount of light in the culvert, and help replicate more natural conditions to increase the chance of fish swimming through the culvert.'



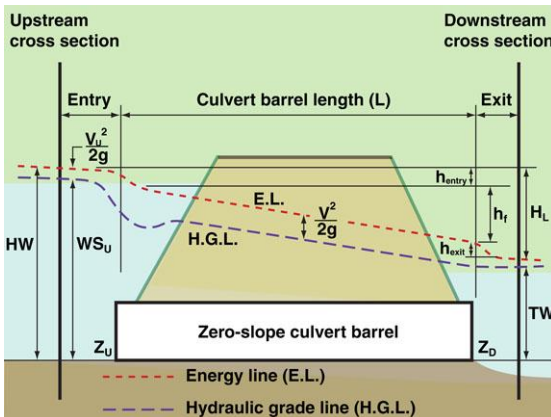
Photo supplied by Catchments & Creeks Pty Ltd

Sunken skylight placed in a road median



Photo supplied by Catchments & Creeks Pty Ltd

Light entering the designated 'wet' cell



Culvert hydraulics

Bed slope

- 'At least one of the culverts (the culvert designated for fish passage) should be constructed on a flat base, not sloping, so that there is no change in water velocity through the culvert.'

Author's note: Installing a flat bed slope will not, on its own, control the water velocity.



Ridge rock fishway (Vic, 2017)

Controlling tailwater conditions

- 'This can be resolved by constructing a small rock riffle downstream to drown out the "step", such that the water level backs up in the culvert.'
- 'A rock apron, or fishway, could also be constructed to allow fish to climb up the step between the bottom of the culvert and the downstream water level.'

Appendix B: The Design Team

The design team



Design team

Introduction

- In order to achieve a functional design, the design team must contain, or have access to, a range of professional inputs.
- A culvert design team would typically consist of:
 - local fisheries expert
 - engineers
 - terrestrial corridor expert.
- Local advice is essential if part of the design team is based at a distant location.



Fisheries biologist

Fisheries biologists

- Biologists (or other suitably trained professionals), are required to:
 - classify aquatic habitats
 - identify target species
 - identify feral species
 - identify migration triggers, timing, and likely movement pathways (i.e. along the bed, banks, or overbank)
 - identify potential conflicts between aquatic passage and terrestrial passage.



Engineer

Engineers

- Engineers and drafting personnel are required to investigate:
 - catchment hydrology
 - culvert hydraulics
 - pedestrian/road/rail design
 - foundation design
 - structural design
 - site revegetation (designers such as landscape architects).



Terrestrial ecologist

Terrestrial ecologists

- Wildlife officers (or other suitably trained professionals), are required to:
 - identify terrestrial movement corridors
 - identify terrestrial movement connectivity
 - identify target species
 - identify feral species
 - identify potential conflicts between aquatic passage and terrestrial passage.

Listening to those people that raise concerns



Happy



Questioning



Concerned



Unhappy

Case Study 1:

- Several years ago I attended a field day where the organisers were claiming that their creek rehabilitation project had demonstrated good cooperation between all parties.
- It was immediately obvious to me that the creek works would have increased floor level flooding of the adjacent homes.
- I ask the organisers if the public was happy with the increased flood rise.
- I was told that consultation had occurred with the local community, and that they were all in favour of the creek works.
- I then asked what the council engineers had to say about the project, and whether or not the community had been informed of the potential increase in local flooding.
- The organisers replied that they had tried to involve the council engineers, but the engineers kept raising flooding concerns, so they stopped talking to the engineers.

So, this work site, that was advertised as a demonstration of 'good cooperation', had in fact chosen to ignore any negative concerns, and had only informed the community of the positive outcomes—sad.

Case Study 2:

- On another project that I worked on, I was informed that I could not raise any concerns unless I was prepared to provide a workable solution to my concerns.
- So, their idea of integrating different opinions was to make sure that:
 - any person raising a concern was responsible for solving that concern
 - no concern was raised that could not be solved.

This was just an example of problem avoidance—sad.

Your responsibility is not limited to your job title

- All professions are responsible for considering the potential impact of their activities on the greater environment.
- Engineers must consider the impact of a waterway culvert on fish passage, terrestrial passage, and public safety.
- Similarly, fisheries officers must consider the potential impact of their fish passage requirements on issues such as terrestrial passage and culvert maintenance.

Appendix C: An Introduction to Fish Passage and Fish Migration

(Drafted by a civil engineer)

Introduction



Aquatic habitat (Qld)



Freshwater turtle (Qld)



Recreational fishing (SA)



Small freshwater fish (Qld)

The importance of maintaining fish-friendly waterway conditions

- Consideration of fish habitat and fish passage issues is important for the following reasons:
 - maintaining healthy aquatic life helps to control mosquito numbers
 - conservation of wildlife diversity
 - conservation of fish breeding habitats
 - recreational and commercial fishing
 - maintaining the linkages between aquatic and terrestrial habitats.

Not just fish

- References to the terms: 'fish-friendly', 'fish habitat' and 'fish passage', do not just refer to fish.
- Fisheries legislation typically defines 'fish' as including:
 - prawns, crayfish, crabs & crustaceans
 - scallops, oysters and molluscs
 - sponges and annelid worms
 - eggs of fish
 - turtles and platypus (possible inclusion).

Not just for the benefit of the fish

- Australian bass and barramundi, both prized recreational fish species, migrate from freshwater into estuaries to spawn, with the juveniles then migrating back upstream.
- Sea mullet, a popular commercially caught fish, enters freshwater habitats as a juvenile, then migrates into estuary waters in preparation for annual spawning.

Not just for the benefit of large fish

- Protecting fish habitats is not just about protecting those fish that are large enough to be caught on a fishing line.
- Small fish exist in most of our waterways, and these fish are very important in providing biodiversity, as well as helping to control mosquito numbers within many of our urban waterways.

Terminology



Fish ladder adjacent to a weir (Qld)



Fish migration in shallow water (SA)



Fish passage (SA)



Baffled fishway

Fish ladder

- A fish ladder is a constructed fishway that requires fish to 'jump' from pool to pool, or cell to cell, in order to climb the fishway.

Fish migration

- Fish migration is the seasonal movement of fish and other aquatic organisms up or down a watercourse as part of their life cycle.
- It is one form of fish passage.
- It does not include the random day-to-day movement of fish in search of food and habitat.

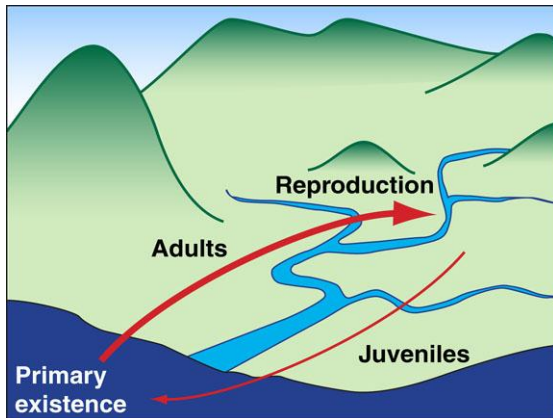
Fish passage

- Fish passage is the collective term for all forms of fish movement up and down a watercourse.
- Movement can be for a variety of reasons including:
 - migration
 - reproduction
 - access to new habitats
 - feeding
 - avoiding predators
 - shelter from floodwaters.

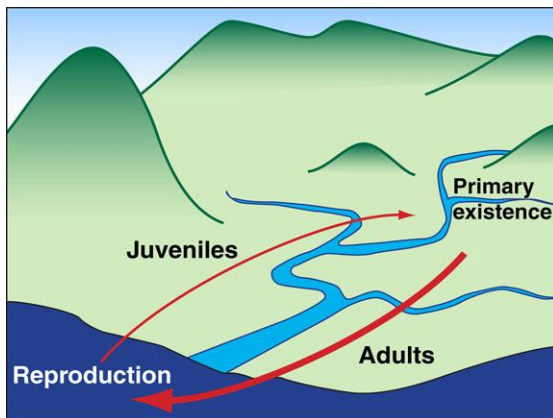
Fishway

- A fishway is a structure designed to enable fish to move past a physical barrier (e.g. dam or weir) in a waterway.
- All fish ladders can be referred to as fishways, but not all fishways operate as fish ladders.

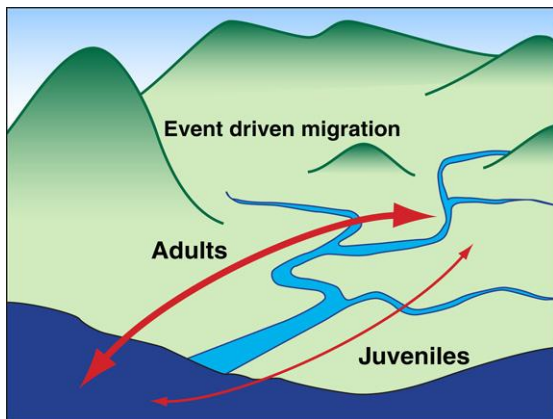
Types of fish migration



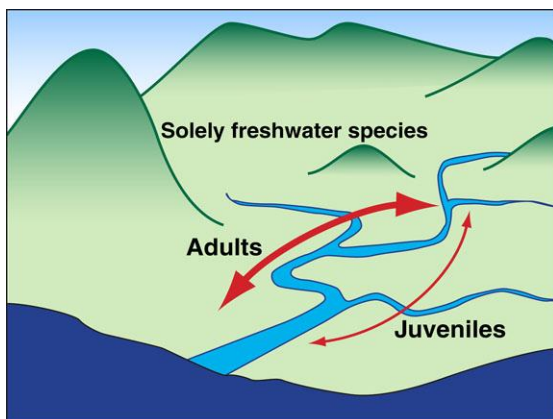
Anadromous fish movement



Catadromous fish movement



Diadromous fish movement



Potamodromous fish movement

The importance of fish passage

- Fish passage along our waterways is critical to the survival of native fish.
- All freshwater fish and some saltwater species, regardless of their size, move within waterways at different times to access food and shelter, to avoid predators, and to seek out mates to breed and reproduce.
- Of the 83 species of freshwater fish in south-eastern Australia, approximately half migrate at least once as part of their life cycle.

Types of fish movement

Examples of the various types and reasons for fish movement include:

- Local movement to access food, avoid predators, and shelter from high temperatures.
- Daily movement to access habitat, food and shelter, and avoid predators.
- Seasonal movement as part of their breeding cycle.
- Upstream movement to access new habitats, or in response to their displacement during flood events.
- Downstream movement after spawning to avoid predators.
- Some fish spend much of their life in a marine environment, but then migrate to freshwater as adults to reproduce.
- Some fish spend most of their life cycle in freshwater, then migrate to the marine environment to reproduce.
- Some fish migrate between waters during a specific period of their life cycle.
- Some fish migrate solely within freshwater environments.

A natural response to flood flows

- Flood events can trigger the upstream migration of some fish species.
- For many other species there is a general need for the fish to progressively move upstream during periods of low-flow in order to counter the effects of flood events which can potentially carry some species well-downstream during flood events.
- This means that **barriers** to fish passage can be a problem even for species that don't need to migrate for the purpose of reproduction.

Fish-friendly waterways



Photo supplied by Catchments & Creeks Pty Ltd

Aquatic habitat and food supply (Qld)



Photo supplied by Catchments & Creeks Pty Ltd

Interconnected habitat ponds (Qld)



Photo supplied by Catchments & Creeks Pty Ltd

Turtle in need of shelter (Qld)



Photo supplied by Catchments & Creeks Pty Ltd

Introduced species (Qld)

Introduction

- **Fish friendly** is a term commonly used to describe a design process that promotes appropriate consideration of aquatic life within the design of a waterway structure.
- To be fish friendly, a project needs to consider the following:
 - aquatic habitat and food supply
 - shelter requirements
 - diversity of aquatic life
 - protection of movement corridors.

Habitat and food supply

- Native fauna require a wide range of habitats to live in, feed and reproduce.
- **Aquatic habitats** usually require high-quality water during periods of low flow, and the shading of permanent water bodies to control water temperature.
- The provision of suitable habitats also requires the temporary or permanent connection of permanent pools in order to allow aquatic life to search for food on a day-to-day basis.

Shelter

- **Shelter** is that part of a fauna habitat that allows wildlife to hide from predators (including humans), and to shelter from adverse weather and flow conditions.
- The provision of shelter integrates well with the ideals of providing hydraulic roughness and habitat diversity.
- Shelter may consist of cavities between submerged rocks, as well as areas of low-velocity water in and around reed beds, rocks, and debris snags.

Biodiversity

- The **biodiversity** of species is important for the maintenance of sustainable ecosystems; however, this does **not** mean that biodiversity should be encouraged beyond that which is natural for the waterway.

The image left was photographed immediately downstream of a freshwater weir (fish passage barrier). The turbidity was the result of recent rainfall-induced stream flows.

The swimming ability of fish



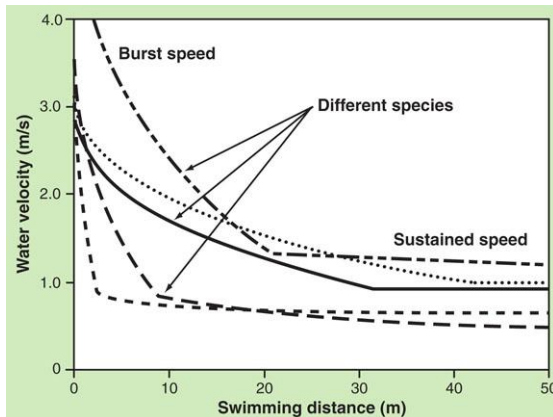
Photo supplied by NSW Fisheries

Pygmy perch (NSW Fisheries)

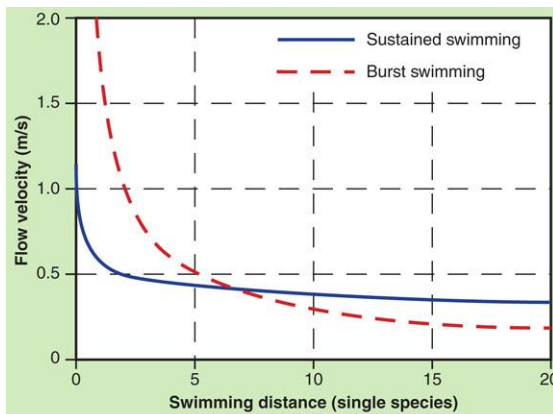


Photo supplied by Catchments & Creeks Pty Ltd

Large fish in shallow water (SA)



Examples of fish swimming ability



Example of speed over distance

Size and species

- The swimming ability of fish varies with each species, and the size of the fish.
- For any given fish (size and species) its swimming speed can be classified into three levels:
 - **Burst speed**, which is able to be maintained for short periods (seconds)
 - **Sustained speed**, a medium speed able to be maintained for minutes
 - **Cruising speed**, which allows fish to maintain continuous movement.

Swimming ability in shallow water

- The swimming ability of fish can also be affected by the depth of the water.
- If the body of the fish is partially exposed, then their swimming speed and endurance can be reduced.
- Some engineering structures, such as flat-bed box culverts, can create shallow water conditions that are difficult for fish to negotiate.

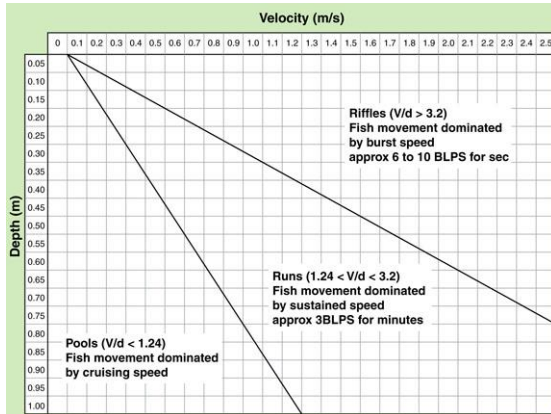
Approximate swimming speeds

- Fish use a combination of burst speed and sustained speed to negotiate many waterway obstacles.
- In general terms, their swimming speed varies with the size of the fish, with:
 - burst speed being approximately 6 to 10 **body lengths per second (BLPS)**
 - sustained speed being approximately 3BLPS.

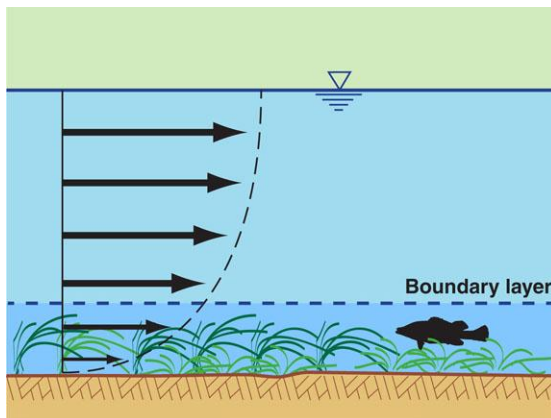
Swimming ability over long distances

- Fish use different muscle groups during different types of swimming.
- During burst swimming the initial speed can be high, but energy levels are quickly exhausted and eventually the swimming speed will fall below that which would have been achieved during sustained swimming.
- This means the effective 'length' of a waterway obstacle is critical in determining if the obstacle is recognised as a barrier to fish passage.

Waterway hydraulics and its interaction with fish passage



Typical flow conditions



Boundary layer flow conditions



Whirlpool in a flooded rural creek (Qld)



Gravel-based creek with boulders (Qld)

Natural obstacles

- Creeks are rarely uniform in their cross-section and bed conditions.
- Fish passage can be obstructed by natural features, such as riffles, rapids, waterfalls, dry creek beds, and disconnected pools.
- To negotiate these obstacles, fish can use:
 - burst speed
 - jumping from the water
 - crawling over damp rocks (used by a very limited number of species).

Variation in flow velocities within a channel

- Fish are aided in their movement by the fact that flow velocities are not uniform across the width and depth of most channels.
- Friction and turbulence alter the local flow velocity, with flow velocities being reduced close to the bed and banks of waterways as a result of friction.
- This 'layer' of lower velocity water is commonly referred to as the **boundary layer**.

The effects of turbulence

- Water turbulence can help to reduce flow velocities, but excessive turbulence can become a barrier to fish passage.
- Small-scale turbulence is most commonly associated with water flowing over rough or irregular surfaces.
- Large-scale turbulence (eddies and whirlpools) can be shed from large irregular objects, or from rapid changes in the direction of the water.

Small backwaters and shadow zones

- A key to good aquatic habitat and fish passage conditions is a diversity in bed conditions.
- The existence of a uniform channel cross-section means flow conditions across the channel will either be 'all good' or 'all bad'.
- Bed irregularities, such as exposed boulders, can provide fish with areas to rest and rebuild their energy prior to continuing their migration, or their search for food.

Fish-friendly bed stabilisation measures



Gravel-based creek (Qld)



Constructed rock ramp/chute (NSW)



Constructed rock riffle (Qld)



Bed level falling downstream of culvert

Desirable creek bed features

- Within fish habitats, bed stabilisation measures should generally aim to provide the following features:
 - bed roughness that simulates the natural bed roughness
 - a diversity of surface conditions that produce a diversity of flow conditions
 - random objects that can provide fish with protection from high-velocity flows
 - a suitable source of food.

Fish-friendly rock ramps

- Rock ramps (rock chutes) are often used to stabilise bed scour problems.
- In order to be fish friendly, these structures need to comply with certain physical and hydraulic requirements:
 - a maximum gradient of around 1 in 20 to 1 in 30
 - a maximum fall of around 500 mm
 - stable outer flanks that provide suitable fish passage conditions during elevated flow rates.

Fish-friendly hydraulic steps

- Ideally, the 'spill height' between two layers of rocks, or any other part of a fishway, should not exceed 100 mm.
- Ideally, hydraulic structures should not be 'uniform' in their flow conditions across the full width of the channel.
- Minor variations in the positioning of rocks means fish can search for their preferred pathway as flow conditions change.
- Such diverse hydraulic conditions are commonly found in natural riffles.

Allowance for future changes in bed levels

- In waterways, nothing stays the same for very long, banks move left and right, creek beds move up and down.
- In order to be fish friendly, all waterway structures must be able to accommodate expected changes in bed level.
- This means:
 - extra rock may need to be placed below the current bed level, and/or
 - 'recessed rock check dams' may need to be installed within some waterways.

Fish-friendly bed stabilisation measures



Habitats formed by placement of boulders

Random placement of boulders

- Rock riffles do not 'naturally' occur in all waterways.
- Similarly, rock boulders do not exist in all waterways.
- However, with the guidance of waterway and fisheries experts, the random placement of boulders can:
 - provide resting areas for fish
 - provide roosting areas for aquatic and terrestrial fauna.



Constructed pool-riffle system (Qld)

Use of pool-riffle systems

- The construction of a series of pools and riffles is one option for the rehabilitation of head-cut erosion within a waterway.
- However, a pool-riffle system is not a natural feature in all types of waterways.
- To be fish friendly:
 - the rocks must be stable during the expected flow range (unlike natural riffles which allow the rocks to move)
 - the total fall of a single riffle should not exceed approximately 500 mm.



Constructed fishway (Qld)

Use of fishways

- Constructed fishways are often used as a component of the rehabilitation of existing non fish-friendly waterway structures, such as culverts and weirs.
- To be fish friendly:
 - the spill height across any ridge should not exceed 100 mm
 - the design of the fishway must be compatible with the natural movement of bed material (i.e. sediment and gravels) during flood events.



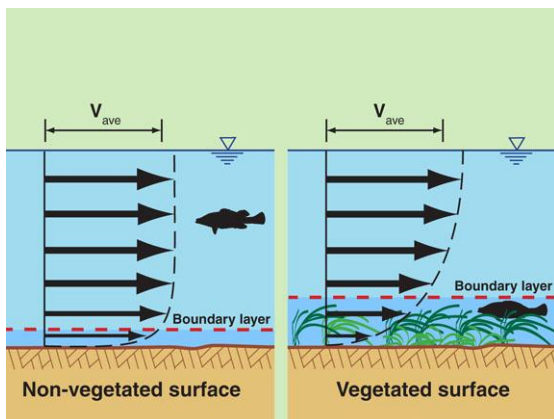
Fish ladder on a river weir (USA)

Use of fish ladders

- A 'fish ladder' is a type of fishway that normally requires fish to 'jump' from pool to pool in order to ascend the fishway.
- In Australia, it is generally preferable for fishways to utilise the 'burst speed' of the fish in order to ascend the fishway, instead of the fish's jumping ability.
- Obtaining advice from fisheries experts is essential prior to the placement of any fishway within Australian waters.

Appendix D: The Importance of the Boundary Layers

Introduction



The benefit of a thick boundary layer



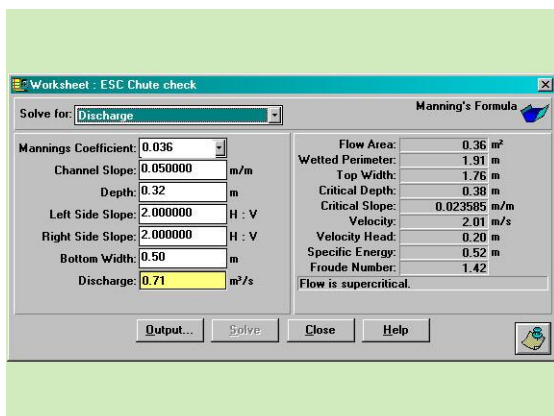
Photo supplied by Catchments & Creeks Pty Ltd

High-velocity stream flow (Qld)



Photo supplied by Catchments & Creeks Pty Ltd

Measuring local flow velocity (Qld)



Simple 1D flow analysis program

Flow velocity

- Flow velocities in a typical waterway channel are highly variable.
- The maximum flow velocity typically occurs at the water surface, near the centre of the channel.
- Flow velocities typically reduce as you move closer to the bed and banks.
- The **local flow velocity** (the velocity at a given point in water column) will always be zero immediately adjacent to a stationary surface.

Defining the flow velocity

- There are several different ways to define the flow velocity, including:
 - **local flow velocity** (measured at a point)
 - **depth-average velocity** (averaged down a vertical plane)
 - **average velocity** (full cross-section)
 - **maximum velocity** (top, centre).
- The average velocity is often much less than the maximum velocity and the depth-average velocity at any given cross-section.

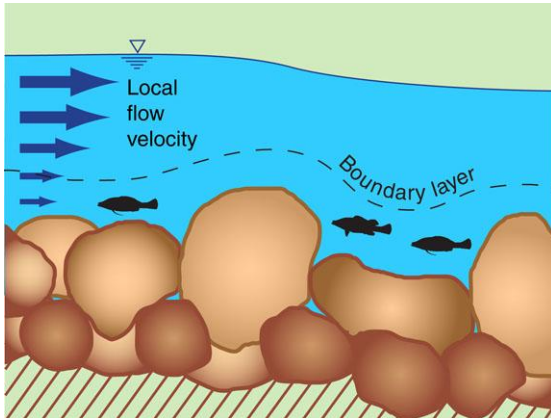
Which flow velocity is of greatest interest to migrating fish?

- Fish care only about the flow velocity in front of their 'nose', thus fish care only about the **local flow velocity**.
- This flow velocity can be easily measured on-site using a hand-held flow meter.
- It is this flow velocity that changes dramatically across a **boundary layer**.
- However, this flow velocity can be highly variable, and can be very difficult to calculate without computer models.

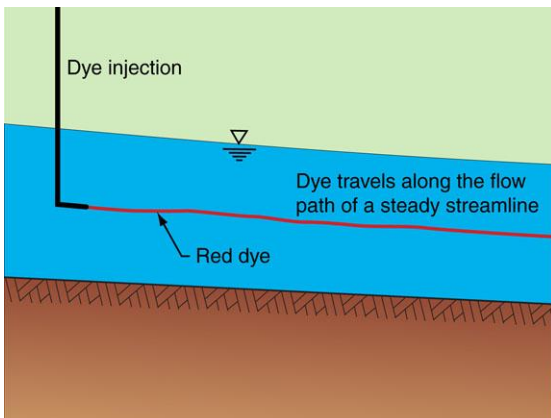
Which flow velocity is of greatest interest to overworked, underpaid, under-appreciated, under-recognised culvert design engineers?

- Hydraulic engineers focus on the **average flow velocity**, because this velocity can be used to calculate:
 - culvert head loss (or energy loss)
 - culvert flow area
 - rock size for scour protection.
- The average flow velocity is easy to calculate, but hard to determine from field measurements.

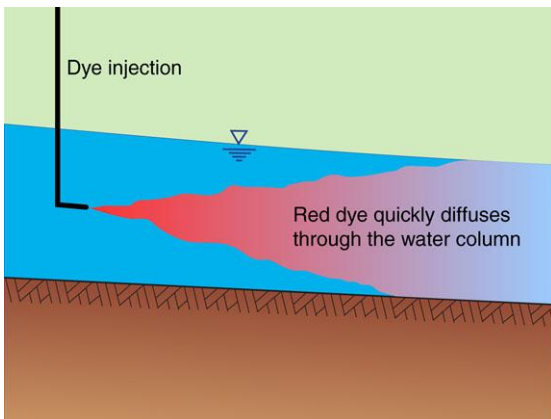
Terminology



Boundary layer formed over a rocky bed



Laminar flow conditions



Turbulent flow conditions



Photo supplied by Catchments & Creeks Pty Ltd

Smooth-turbulent flow over a road (NSW)

Boundary layer

- A **boundary layer** is a region of lower than average flow velocities that exists immediately adjacent any fixed surface, such as the bed and sidewalls of a culvert.
- In general, the rougher and more irregular the fixed surface is, the thicker and the more effective the boundary layer is for fish passage.

Laminar flow

- **Laminar flow** is a flow condition characterised by fluid particles moving along smooth layers, with one layer gliding over an adjacent layer.
- The viscous properties of the fluid suppress any random motion (turbulence) of the fluid particles, thus preventing mixing between adjacent layers.
- Fisheries officers and engineers often use this term to refer to any flow that has low turbulence, but this is not 'technically' correct.

Turbulent flow

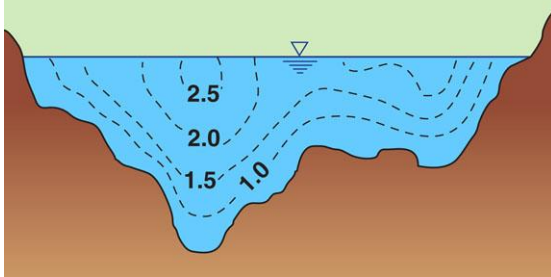
- **Turbulent flow** is a flow condition characterised by fluid particles moving along irregular flow paths.
- The viscous properties of the fluid are insufficient to suppress any turbulent motion of individual fluid particles, which results in an exchange of momentum and mixing between adjacent layers.
- There are various classes of turbulent flow, including smooth-turbulent, turbulent, and wholly-rough flow.

Smooth-turbulent flow

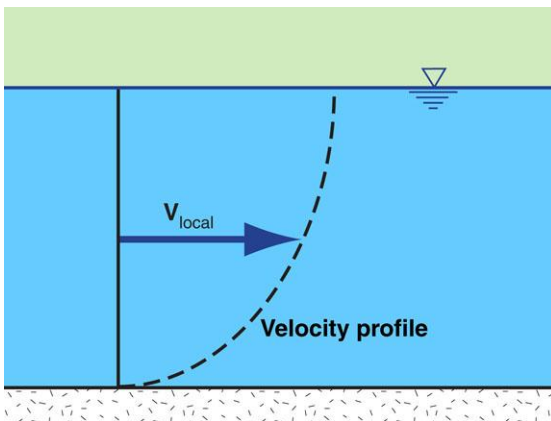
- **Smooth-turbulent flow** is a condition where turbulence is limited, and large eddies generally do not exist, but full mixing does occur.
- Smooth-turbulent flow conditions normally exist only in low-gradient channels that have a uniform cross-section, and few surface irregularities.
- Smooth-turbulent flow is the flow condition that would be considered the ideal environment for fish, except in large ponds where near-still water exists.

Defining the flow velocity

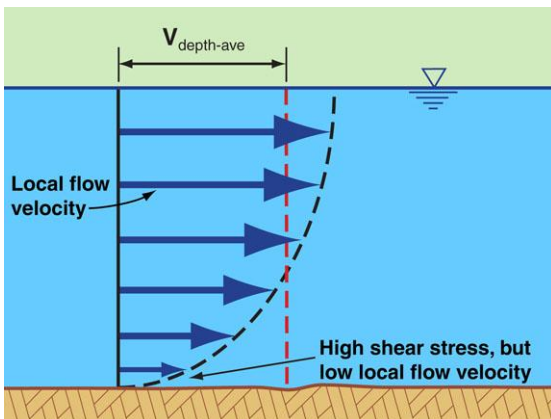
Velocity profile in a straight channel reach



Velocity contours in an open channel



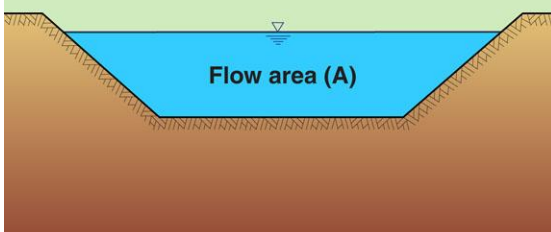
Local flow velocity



Depth average flow velocity

Total discharge: Q

Average velocity: $V = Q/A$



Cross-sectional flow parameters

The confusing thing about flow velocity

- If an engineer were asked to identify where, along a given reach of a waterway, flow velocities would be less than 0.3 m/s, the answer would be: 'everywhere'.
- Even though the **average velocity** may be 3 m/s across the channel, the **local flow velocity** would vary from maximum to zero across any given cross-section of the channel.
- So, wherever there is a channel bed or bank, there will always be a region of flow velocity that is less than 0.3 m/s.

Local flow velocity

- The **local flow velocity** is the flow velocity at a specific point within a cross-section.
- The local flow velocity is the velocity of most importance to fish because it is this velocity that they confront when swimming upstream.
- In creek engineering, the local flow velocity is rarely used because it is so hard to calculate mathematically, even though it is relatively easy to measure in the field.

Depth-average flow velocity

- The **depth-average velocity** is the average of the local flow velocities measured down through a vertical plane.
- The depth-average velocity typically varies across the width of a channel.
- This flow velocity is used by creek engineers in the design of some scour protection measures, such as rock.
- It is noted that some engineers refer to the depth-average velocity as the 'local velocity' (which can cause confusion).

Average flow velocity

- The **average flow velocity** is defined as the total discharge (Q) divided by the total flow area (A) at a given cross-section.

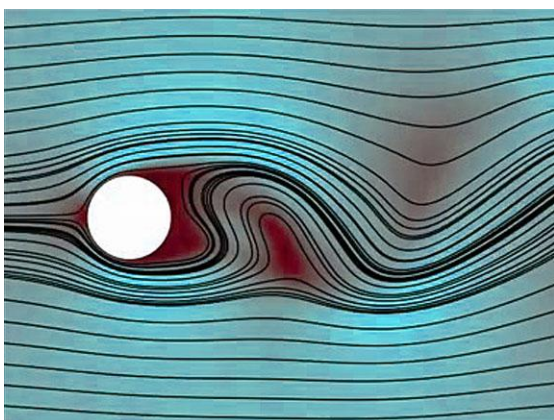
$$V = Q/A \text{ [m/s]}$$

- In complex cross-sections there may be areas of zero flow due to flow isolation; in such cases these areas may be excluded from the total flow area.
- The symbol for velocity is normally a lower case 'v', but an upper case 'V' is often used in publications, such as this field guide.

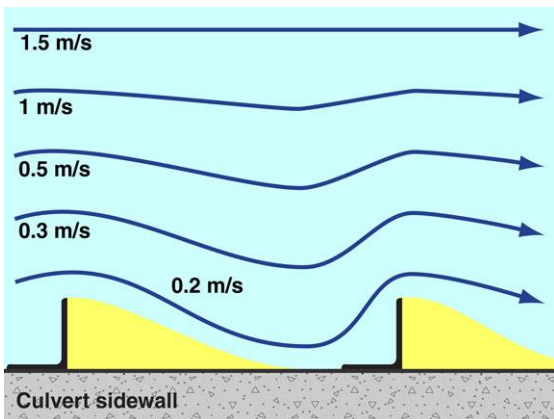
Problems associated with the flume-tested fish swimming speeds



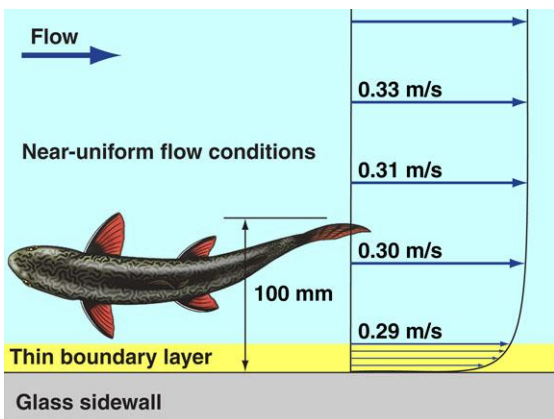
Wave flume, University of NSW



Typical hydraulic research testing



Testing sidewall baffles



Testing sidewall baffles

Introduction

- Hydraulic testing flumes are typically found at universities and within equipment testing laboratories.
- The author worked at the University of NSW, Water Research Laboratory (WRL) between the years 1981 to 1991.
- The Water Research Laboratory has several flumes, some designed for wave testing, some for velocity testing.

Flow velocity within a testing flume

- A velocity-based flume (if I can call it that) is designed to test velocity-related issues, such as:
 - drag force coefficients
 - flow around fixed objects
 - swimming speeds.
- These flumes are built to have very smooth surfaces so that bed and sidewall boundary layers are as thin as possible.
- The aim is to produce near-uniform flow velocities across the flume.

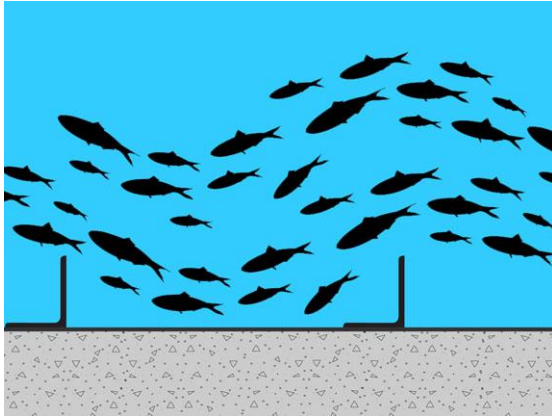
Testing swimming speeds in glass flumes

- The operation of a testing flume involves water entering an inlet chamber, from where the water passes through a flow calming grid before entering the main channel.
- The flow rate is adjustable, which allows for changes in flow velocity.
- The time it takes for fish to swim along a measured length of the flume, against an opposing flow velocity, can inform researchers how long fish can maintain their burst speed.

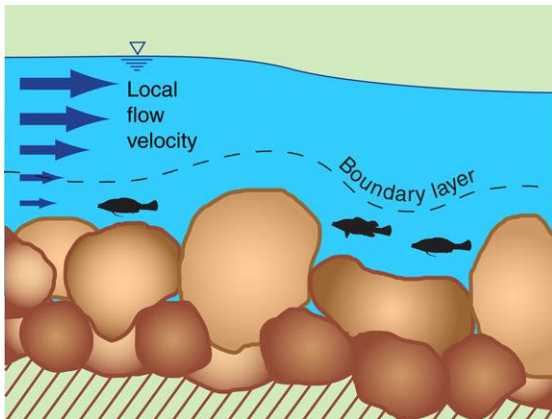
The problem with testing swimming speed in glass flumes

- Flume testing can only indicate the difficulties fish face when trying to swim through a smooth-wall culvert.
- It is only when bed roughness, or sidewall baffles, are introduced to the flume that realistic fish passage data is obtained.
- Unfortunately, most 'burst speed' data for fish species is based on a flow condition that we are trying to avoid in modern, fish-friendly culverts.

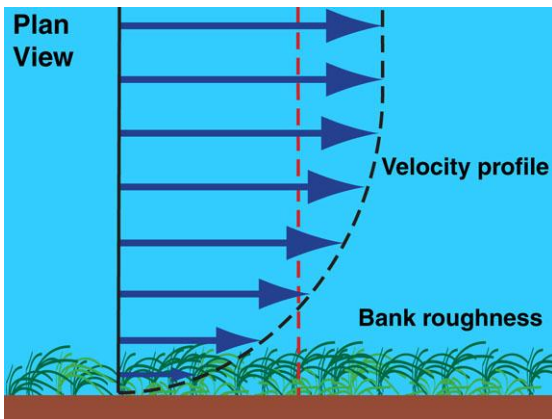
How fish use boundary layers to migrate along high-velocity streams



Fish passage along a baffled sidewall



Boundary layer formed over a rocky bed



Boundary layer adjacent grass-like plants



Photo supplied by Catchments & Creeks Pty Ltd

Fish trapped after a flood event (Qld)

Introduction

- If you gain just one thing from this document, please learn that fish and engineers have different priorities.
- **Engineers** care about the average flow velocity.
- **Fish** care about the local flow velocity that is in front of their nose.
- **Large fish** want thick boundary layers.
- **Small** or juvenile (fry) fish prefer thin, low turbulence, boundary layers.

Moving over the channel bed

- The thickness of a boundary layer is governed by:
 - surface roughness (friction)
 - surface irregularities (turbulence linked to such things as rock size), and
 - the sediment concentration within the water (affecting its viscosity).
- The boundary layer that forms over the bed of a waterway will be thicker if the bed rocks (gravels) vary in size, rather than being uniform in size.

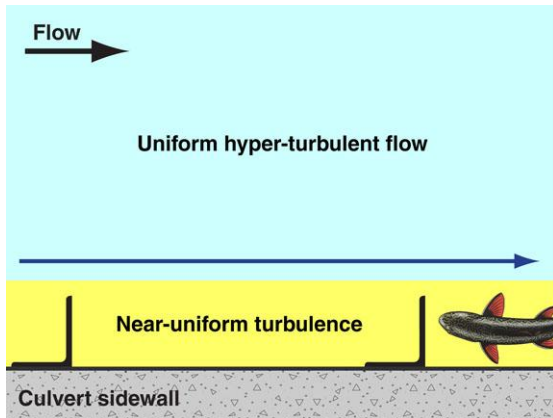
Moving through bank vegetation

- One of the biggest misunderstandings people have about the function of waterway plants is the idea that it is the plant's root system that is responsible for controlling soil erosion.
- In fact, it is the hydraulic roughness of the plant that often (not always) has the greatest impact on controlling soil erosion, (i.e. scouring) because of its ability to build a low-velocity boundary layer over the bed and banks of the channel.

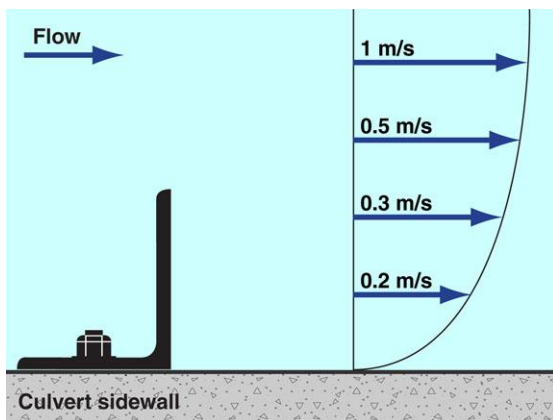
Moving over floodplains

- Some fish migrate along floodplains during flood events.
- Some of these fish can become stranded in off-stream pools and wetlands when floodwaters recede.
- While passing over floodplains, fish can use the same types of boundary layer development that occurs within waterway channels.

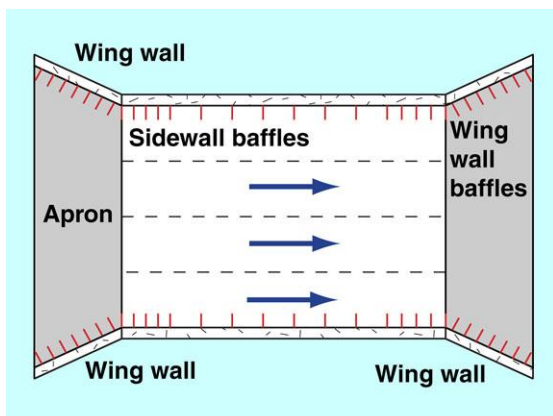
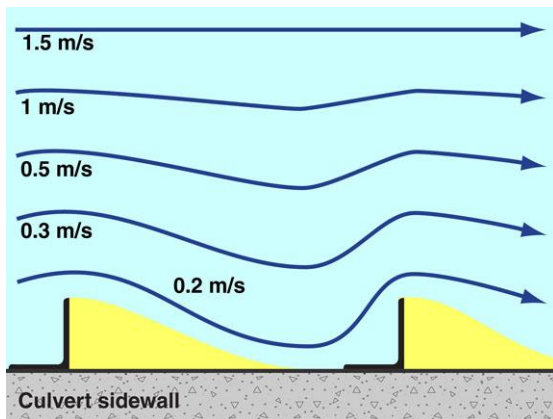
Critical properties of a fish-friendly boundary layer



Resting zone



Local flow velocity



Location of sidewall baffles

Introduction

- The critical properties of a fish-friendly boundary layer are:
 - location of the boundary layer
 - continuity of the boundary layer
 - thickness of the boundary layer
 - degree of large-scale turbulence within the boundary layer (relative to the thickness of the boundary layer)
 - the potential for resting zones to exist within, or linked to, the boundary layer.

Flow velocity within the boundary layer

- The **flow velocity** that exists within a boundary layer is obviously an important factor; however, this flow velocity is highly variable, and difficult to define.
- The flow diagrams shown in this document give the impression of well-organised and controlled flow conditions, but the reality is far different.
- Flow velocities are usually highly variable, both in space and in time.

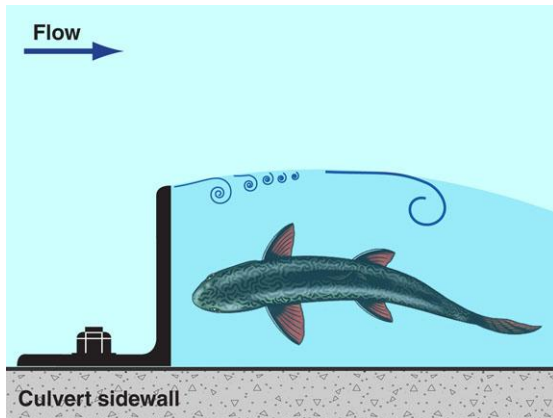
Width or thickness of the boundary layer

- The **thickness** of a boundary layer depends on how the researcher wants to define it.
- There are really no widely-accepted definitions on the lateral limits of a boundary layer—some base it on 90% of the maximum local velocity, others may base it on 90% of the average velocity.
- The thickness of the boundary layer can also vary with time if the boundary layer is affected by flow turbulence; say, from a baffle.

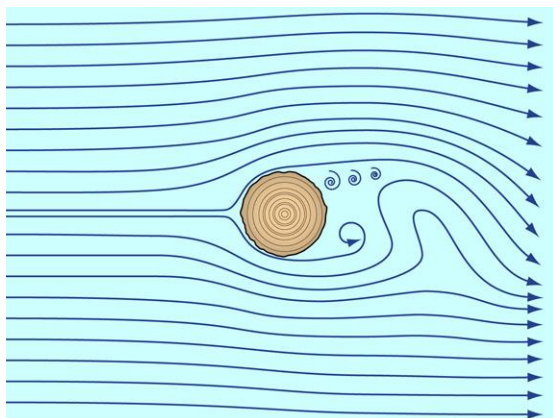
Connectivity of the boundary layer

- Connectivity is possibly the most important property of a boundary layer.
- Fish must be able to move from the downstream bank, to the culvert apron or wingwall, into the culvert barrel, then back onto a wingwall, and finally onto the upstream bank or floodplain.
- Fish can use burst speed to jump across breaks in a boundary layer, but this can give preference to the passage of larger fish over smaller species.

Fish passage interaction with eddies and flow turbulence



Resting zone



Small eddies adjacent to a wooden stake



Photo supplied by Catchments & Creeks Pty Ltd

Large-scale eddies at a debris blockage



Photo supplied by Catchments & Creeks Pty Ltd

Turbulent flow at a rock ramp (Qld)

Introduction

- As discussed, boundary layers can provide favourable hydraulic conditions for fish passage; however, the creation of these boundary layers can create problems, such as:
 - small and large eddies
 - general flow turbulence.
- On the other hand, the generation of boundary layers can sometimes form:
 - resting areas
 - regions of backflow (reverse flow).

Small eddies

- With respect to fish passage, **small eddies** could be defined as circulating turbulence with a diameter less than the width or depth of the fish, whichever is greater.
- The potential impact of small eddies on fish passage could be compared to the human equivalent of:
 - A small yapping dog is unlikely to prevent you from reaching the fridge and enjoying a quick snack, but it will remain annoying until the dog stops.

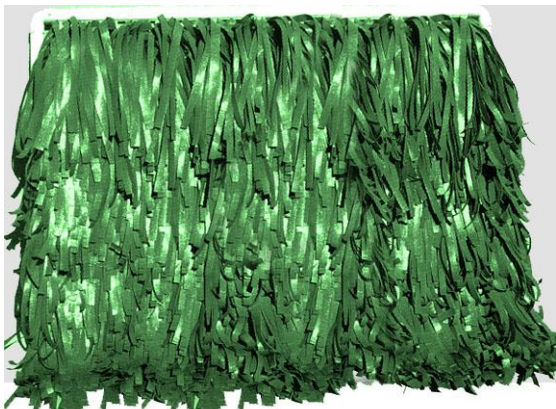
Large-scale eddies

- With respect to fish passage, **large-scale eddies** could be defined as a whirlpool that has a diameter greater than the body length (BL) of a fish.
- The potential impact of large-scale eddies on fish passage could be compared to the human equivalent of:
 - Receiving really poor street directions that sends you way off your desired travel path. Not only do you get lost, but you also struggle to remember where you have come from.

Turbulence

- With respect to fish passage, general flow **turbulence** could be defined as lots of irregular small eddies travelling in slightly different directions.
- The potential impact of general turbulence on fish passage could be compared to the human equivalent of:
 - The constant nagging from a family member—eventually it will drain all your energy, and make you give-up on achieving your goals, or moving forward with your life ambitions.

Techniques for generating boundary layers



Artificial grass panel (Qld)

Surface roughness

- Artificial plants (grass) can be used to increase the effective surface roughness of culvert walls without causing potential debris blockages.

Note: Micro-plastic concerns associated with plastic-based solutions.

The author is unaware of this concept ever being approved or trialled in Australia.

The concept is presented here only to identify the value of boundary layer development.



Photo supplied by Catchments & Creeks Pty Ltd

Introduced rock roughness (NSW)

Surface irregularities

- Bed roughness can be generated by:
 - natural bed sediments
 - imported loose rocks
 - imported rock fixed to the culvert bed
 - pre-cast concrete roughness units.
- The choice of bed roughness needs to be linked to the natural characteristics of the waterway, whether clay-based, sand-based, gravel-based or rock-based.



Bed roughness units

Pre-cast roughness units

- Pre-cast concrete units have been designed for placement of the floor and sidewalls of both box and pipe culverts.
- [Appendix E](#) discusses the flow characteristics of the different types of baffles and roughness units.
- [Appendix F](#) presents information on the hydraulic properties of baffles and roughness units.



Photo supplied by Catchments & Creeks Pty Ltd

Sidewall baffles (NSW)

Sidewall roughness

- Culvert sidewall roughness may consist of:
 - plastic baffles
 - solid metal baffles
 - pre-cast concrete baffles.
- Sidewall baffles can be full-height, or short-length staggered units.
- The wrong choice of sidewall baffle can result in woody flood debris becoming trapped within the culvert cell, which can capture non-woody debris, which can ultimately block any fish passage.

Appendix E: Baffle Selection and Design

Introduction



Wake-up

Introduction

- Fish passage is not just about the things that YOU are interested in.
- Fish passage requires consideration of the needs of the waterway, the needs of aquatic fauna, the needs of terrestrial fauna, the needs of the community, and the needs of the asset manager.
- If the adopted fish passage features can adversely affect other issues, then consideration must be given to those other issues.



Photo supplied by Catchments & Creeks Pty Ltd

The needs of the waterway (Qld)

The needs of the waterway

- In engineering we know there are many aspects to a culvert design—the passage of water (hydraulics), foundations, traffic, structural, electrical, etc.
- But there is also aquatic passage, terrestrial passage, human passage, and the actions (needs) of the waterway.
- **Waterway issues** could include:
 - channel migration
 - migration of bed material (substrate)
 - changes in bed elevation.



Photo supplied by Catchments & Creeks Pty Ltd

Turtle passing over a causeway (Qld)

The needs of the fish

- As discussed several times already, being a fisheries biologist does not mean your considerations are only limited to fish passage.
- Our environmental duty requires everyone to consider all potential impacts.
- The needs of 'fish' includes: fish habitat, fish passage, fish migration, and the movement of: crustaceans, scallops, eels, turtles, platypus, etc.
- It is NOT just about the fish!



Photo supplied by Catchments & Creeks Pty Ltd

Pedestrian culvert underpass (Qld)

The needs of human & terrestrial passage

- The **human needs** of a waterway culvert are likely to include:
 - vehicle movement
 - pedestrian movement
 - safety for underpass users.
- The **terrestrial needs** of a waterway culvert are likely to include:
 - movement corridor
 - habitat (typically for lizards)
 - protection from vehicular traffic.

The needs of the asset manager

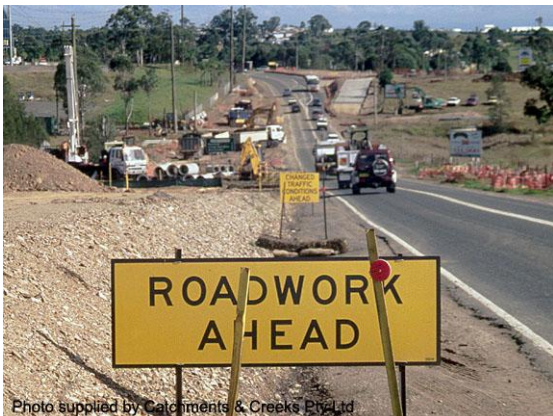
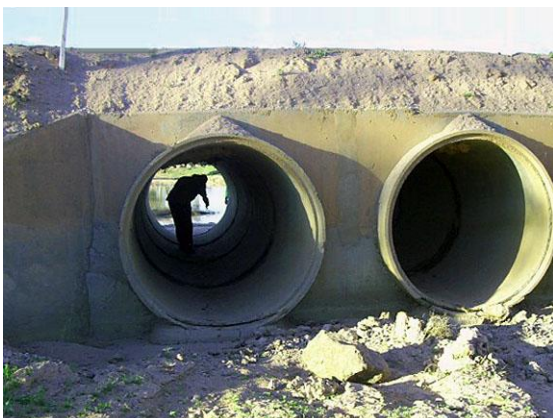


Photo supplied by Catchments & Creeks Pty Ltd

Road works (NSW)



Culvert inspection (Qld)



Photo supplied by Catchments & Creeks Pty Ltd

Flood damage to waterway crossing (Qld)



Photo supplied by Catchments & Creeks Pty Ltd

Local children's in-culvert 'club house'

Introduction

- The needs of the **asset manager** with respect to baffle design include:
 - no adverse impacts on flooding
 - minimise the capture and blockage of flood debris
 - affordable construction cost
 - affordable post-flood maintenance
 - ease of replacement (if damaged)
 - culvert features that do not entice children to enter culverts.

Maintenance and structural inspections

- Culverts are typically inspected annually to check their structural integrity, and to identify required maintenance.
- Waterway crossings are also inspected after each major flood event to check for damage and any maintenance needs.
- Strict safety rules apply to these inspections (**Workplace Health & Safety**).
- Officers need safe access to inspect waterway culverts.

Post-flood maintenance

- Post-flood maintenance typically involves:
 - structural inspection
 - removal of debris
 - de-silting the culvert
 - repairs to handrails.
- Strict safety rules apply to these inspections (**Workplace Health & Safety**).
- Officers need safe access to these structures, which may include access to inlet and outlet aprons.

Asset management

- Waterway culverts are known to be regularly used by the local youth, including:
 - hiding stolen push bikes
 - 'secret' club houses
 - providing access under property fences, or into industrial complexes.
- Asset managers need safe access to the culvert cells to remove offending items.

Summary of sidewall baffle design (Photos by Gunther Schmida)

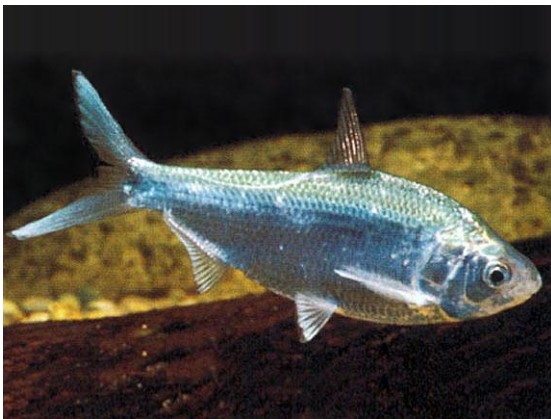


Photo by Queensland Museum

Crimson-spotted Rainbowfish



Common Archerfish



Bony Bream



Black Catfish

Grouping fish according to body length

- For the purpose of this document, fish species have been grouped into three body length (BL) categories.
- **Small fish** have a body length < 150 mm.
- **Medium fish** body length 150 to 400 mm.
- **Large fish** body length > 400 mm.
- What is defined as a 'large' fish is relative to the species of fish likely to inhabit the waters crossed by a culvert, not the species found along the full length of the waterway.

Recommended baffle width

- The baffle's protrusion width should be based on the largest of the target species.
- **Small fish**, at least 50 mm baffle width.
- **Medium fish**, at least 100 mm baffle width.
- **Large fish**, at least 200 mm baffle width.
- If larger migrating fish, with a body length greater than 400 mm, are to be expected to pass through a culvert, then the recommended baffle width is 300 mm.

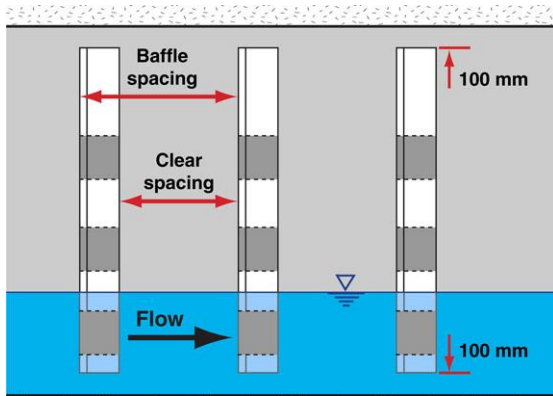
Assumed fish dimension (for the purpose of this numerical analysis)

- Based on an average of 70 species, the **typical body length** is likely to be 0.67 times the **maximum body length** of that species (excluding eels).
- Body thickness is **assumed** to be:
 - small fish body width < 20 mm.
 - medium fish body width < 40 mm.
 - large fish body width < 100 mm.
- The body width is not strictly critical.

Baffle clear spacing (L_c)

- Six (6) times the baffle width for baffle widths less than 100 mm
- Five (5) times the baffle width for baffle widths less than 200 mm
- Five (5) times the baffle width for baffle widths greater than, or equal to 200 mm, and flow velocity is **less than 2 m/s**.
- Four (4) times the baffle width for baffle widths greater than, or equal to 200 mm, and flow velocity is **greater than 2 m/s**.
- Four (4) times the baffle width on the culvert wingwalls.

Summary of baffle spacing



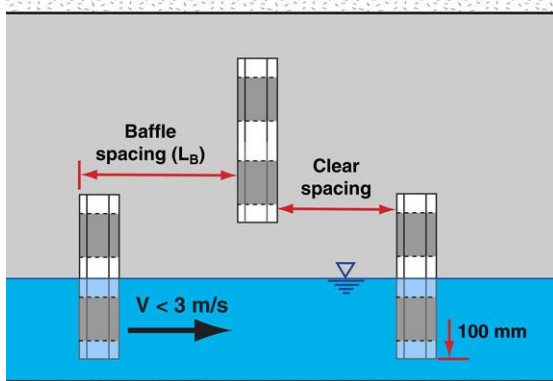
Full-height baffles

Full-height baffles

- Full-height baffles are placed at an even leading-edge to leading-edge spacing of L_B .

Note: The baffle spacing (L_B) is the clear spacing (L_C) plus the baffle depth (D_B).

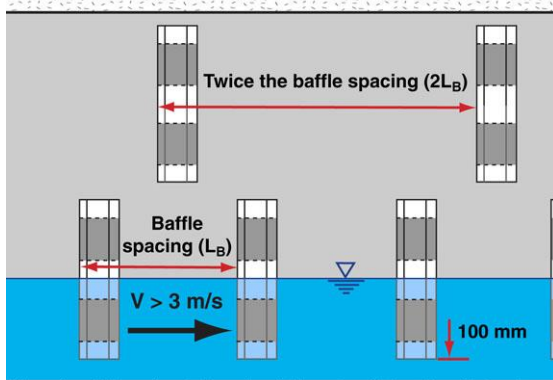
Note: The baffle depth (D_B) is the effective depth (side width) of the baffle measured in the direction of flow, which can be significant for the pre-cast concrete baffles.



Low velocity during low flows

Short-length sidewall baffles

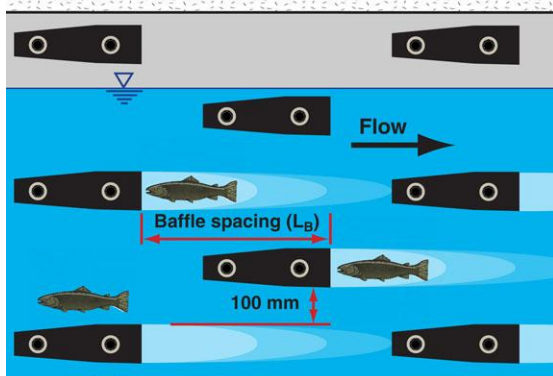
- If the average flow velocity of the culvert cell is **less than 3 m/s** when the water level is below the top of the lowest row of baffles (i.e. low flow condition), then:
 - the short-length baffles remain staggered in their position
 - two or more rows of baffles can be used
 - the spacing of baffles on any given row is twice the nominated baffle spacing ($2L_B$).



High velocity during low flows

High velocity during low flows

- If the average flow velocity of the culvert cell is **greater than 3 m/s** when the water level is below the top of the lowest row of baffles, then:
 - two or more rows of baffles can be used
 - the baffle spacing on the lowest row is the nominated baffle spacing (L_B)
 - the baffles on the higher rows is twice the nominated baffle spacing ($2L_B$).

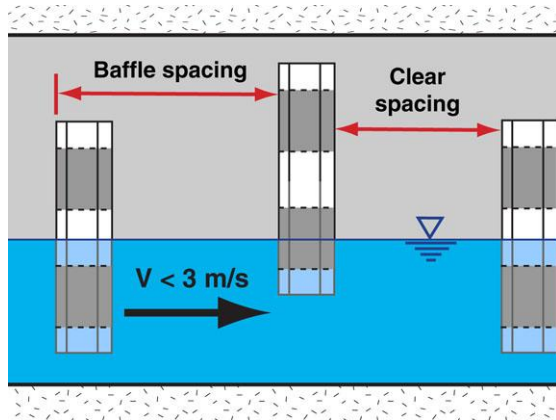


Sidewall roughness units (spoiler baffles)

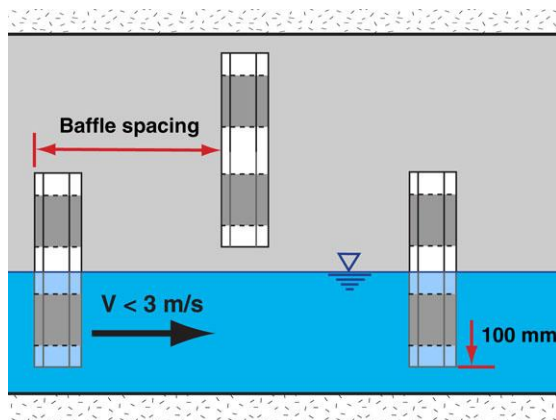
Sidewall roughness units (spoiler baffles)

- The spacing of isolated roughness units **along any given row** is twice the nominated baffle spacing ($2L_B$).
- Thus the lateral spacing between two baffles in adjoining rows is the nominated baffle spacing (L_B).
- The clear vertical spacing between two baffles in adjoining rows is suggested to be 100 mm.

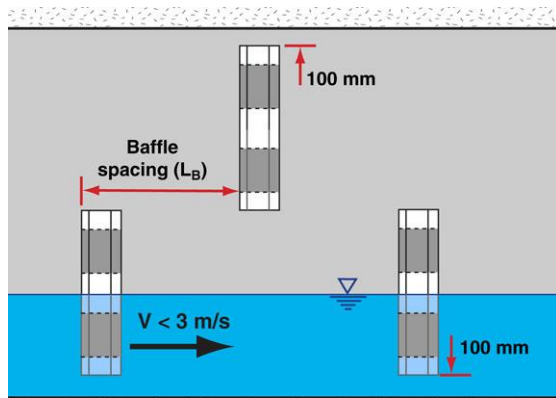
Summary of the vertical positioning of short-length baffles



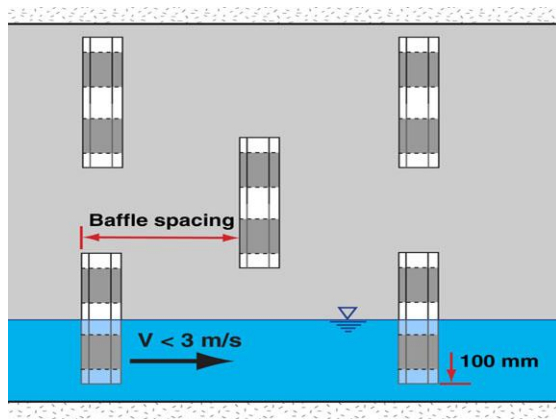
Low-height culvert



Slightly higher culvert



A higher culvert



A tall culvert

Low-height culverts

- Baffles staged in height:
 - first; 100 mm above the culvert floor, or the expected permanent sediment elevation, whichever the case may be
 - next; 100 mm below the roof.

Slightly higher culverts

- Baffles staged in height:
 - first; 100 mm above the culvert floor, or the expected permanent sediment elevation, whichever the case may be
 - next; 100 mm below the roof.

Even higher culverts

- Baffles staged in height:
 - first; 100 mm above the culvert floor, or the expected permanent sediment elevation, whichever the case may be
 - next; 100 mm below the roof.
- The upper row of baffles no higher than 200 mm above the lower row of baffles.

Tall culverts

- The top row of baffles 100 mm below the roof.
- An upper row of baffles no higher than 200 mm above the immediate lower row of baffles.
- The bottom row of baffles 100 mm above the culvert floor, or the expected permanent sediment elevation, whichever the case may be.

Table E1 – Suggested suitability of baffle types in different waterways

Baffle type	Type of waterway				
	Clay based	Sand based	Gravel based	Rock based	Arid & semi-A.
Full-height section baffles	Yes	?	?	Yes	Yes
Short-length sidewall baffles	Yes	Yes	Yes	Yes	Yes
Sidewall roughness units (spoiler baffles)	Yes	Yes	Yes	Yes	Yes
Sidewall roughness panels	?	?	?	?	?
Porous modular units	?	No	No	?	?
Longitudinal baffles	?	?	?	?	?
Corner baffles	Yes	No	No	Yes	?
Floor baffles	?	No	No	Yes	?
Yes = Useful	No = Not recommended		'?' = Questionable value		

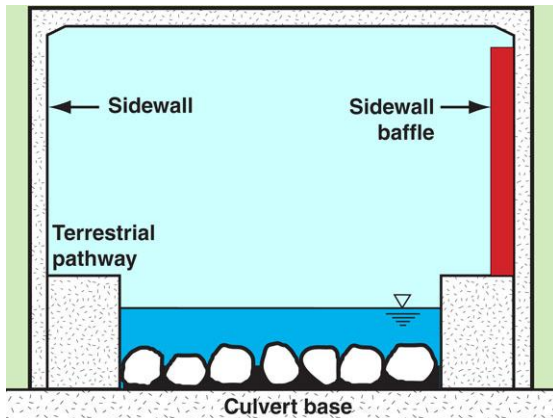
Table E2 – Suitability of baffles for various bed load and flood debris conditions

Baffle type	Movement of bed sediments and flood debris				
	Urban waterway	No sediment	Sediment movement	No flood debris	Flood debris
Full-height section baffles	Yes	Yes	?	Yes	?
Short length sidewall baffles	Yes	Yes	Yes	Yes	Yes
Sidewall roughness units	Yes	Yes	Yes	Yes	Yes
Sidewall roughness panels	?	?	?	?	?
Porous modular units	?	Yes	No	Yes	No
Longitudinal baffles	?	?	?	?	?
Corner baffles	?	Yes	No	Yes	?
Floor baffles	?	Yes	No	Yes	?
Yes = Useful	No = Not recommended		'?' = Questionable value		

Table E3 – Suggested location of baffles within multi-cell culverts

Baffle type	Expected timing of fish passage				
	Daily all year	During low flows	Elevated flows	Flood events	Specific time of year
Sidewall baffles	Yes	?	Yes	Yes	Yes
Corner baffles	Yes	Yes	Yes	Yes	Yes
Floor baffles	Yes	Yes	Yes	?	Yes
Adjacent to waterway bank	Yes	?	Yes	Yes	Yes
Internal 'dry' cells	?	No	?	Yes	Yes
Internal 'wet' cells	Yes	Yes	Yes	?	Yes
Low-flow 'wet' cell	?	Yes	?	?	?
Yes = Useful	No = Not recommended		'?' = Questionable value		

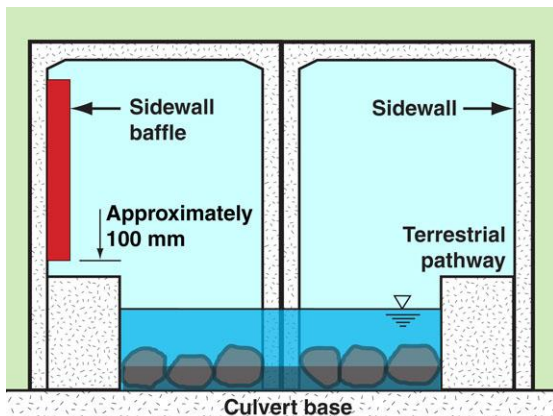
Positioning of baffles within single, twin-cell, and multi-cell culverts



Single cell culvert

Single cell culvert

- If the waterway is so narrow that a single cell culvert can be used to cross the channel, then sidewall baffles are only likely required along **one side of the culvert**.
- Designers need to confirm this requirement with the local Fisheries office.



Twin-cell culvert

Twin-cell culvert

- If the waterway is so narrow that a twin-cell culvert can be used to cross the channel, then sidewall baffles are only **likely to be required** along one side of the culvert.
- If a multi-cell culvert is wider than it is deep, then consideration should be given to sidewall baffles placed adjacent to **each** waterway bank.
- Designers should confirm this requirement with the local Fisheries office.

Multi-cell culverts:

Cell adjacent to the waterway bank [1]

- If fish passage is likely during flood events, then sidewall baffles should be located adjacent to both channel banks.
- These baffles would likely extend to near the roof (obvert) of the culvert cell.

Nominated 'dry' cells (but not above) [2]

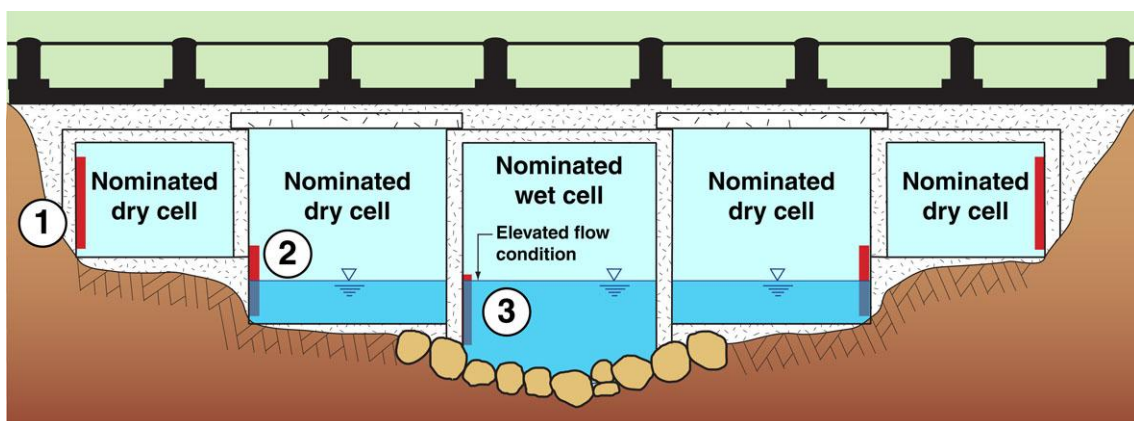
- If fish passage is likely during elevated flows (non-flood events), then sidewall baffles may need to be located within internal 'dry' cells if there is an elevation difference compared to the 'wet' cells (as shown in the example below).

Nominated 'wet' cells [3]

- If fish passage is likely on a day-to-day basis, then sidewall baffles may be required along one side of the nominated 'wet' cell.

Exceptions for low velocity cases

- An exception exists to all of the above; if the average flow velocity through the culvert is less than 0.3 m/s during any of these flow conditions (such as low flows), in which case, sidewall baffles are unlikely to be required for that particular flow condition.



Positioning of baffles in multi-cell culverts

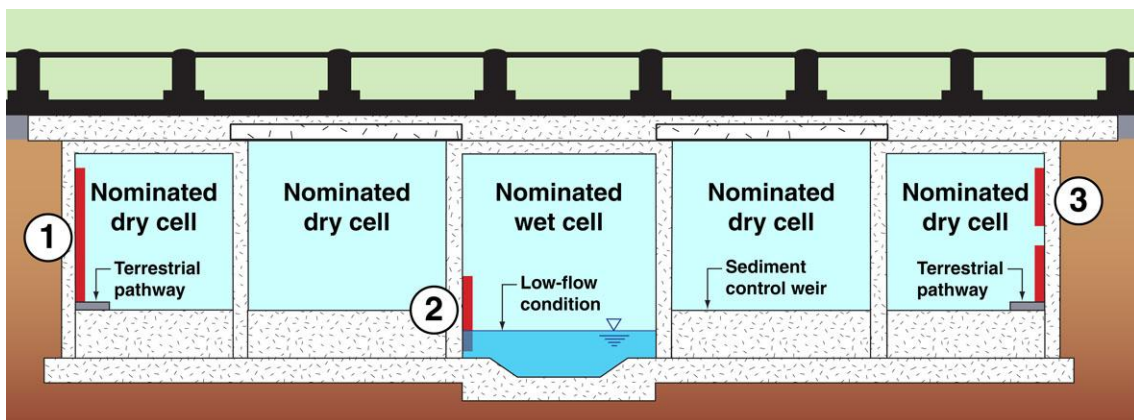


Photo supplied by Catchments & Creeks Pty Ltd

Culvert with sediment control weirs (Qld)

Multi-cell culvert with sediment control weirs

1. If fish passage is likely during flood events, then sidewall baffles should be located adjacent to both channel banks.
2. If fish passage is likely on a day-to-day basis, then sidewall baffles should be located on one side of the nominated 'wet' cell.
3. Alternatively, short-length sidewall baffles, or sidewall roughness units (spoiler baffles), can be used.



Multi-cell culvert with sediment control weirs

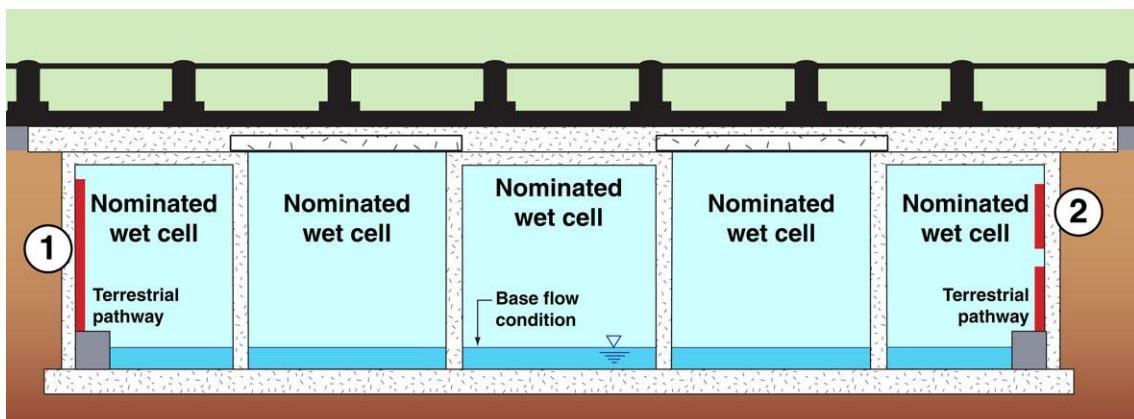


Photo supplied by Catchments & Creeks Pty Ltd

Multi-cell culvert with flat bed (NSW)

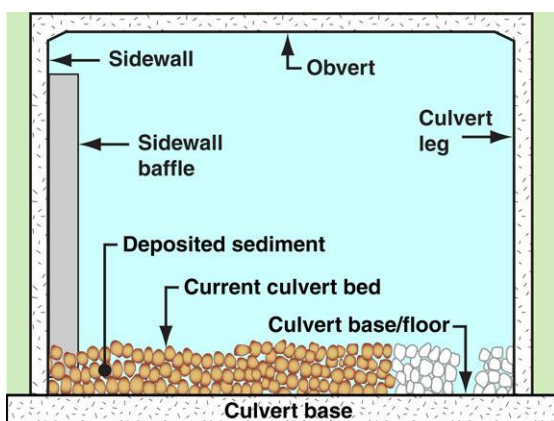
Recessed multi-cell culvert with flat bed

1. Sidewall baffles should be located adjacent to both channel banks.
2. Alternatively, short-length sidewall baffles, or sidewall roughness units (spoiler baffles), can be used.



Recessed multi-cell culvert with flat bed

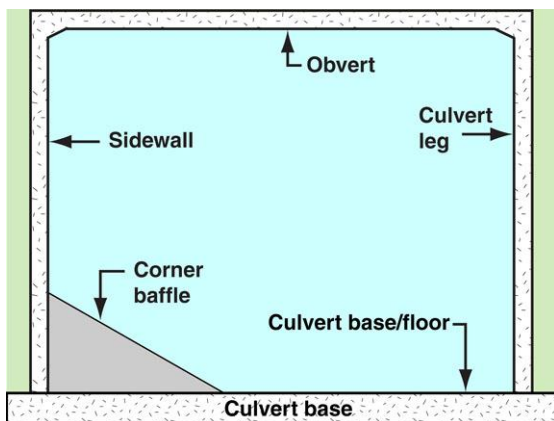
E1 - Baffle Design Options



Sidewall baffle

Sidewall baffles

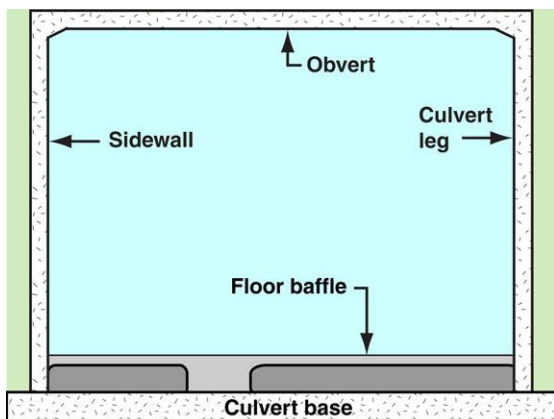
- Sidewall baffles are used when:
 - required by legislation
 - critical fish passage is likely to occur over a wide range of flow conditions (independent of the type of waterway)
 - fish passage is likely to occur during flood events
 - the culvert is located on a [sand-based](#) or [gravel-based](#) (alluvial) waterway that is likely to make floor-based baffles inoperative.



Corner baffle

Corner baffles

- Corner baffles are used when:
 - required by legislation
 - critical fish passage is likely to occur at a set time of the year when stream flows are more likely to be minor in-bank flows
 - the culvert is located on a [clay-based](#) or [rock-based](#) waterway that does not experience significant sediment (substrate) movement along the bed.

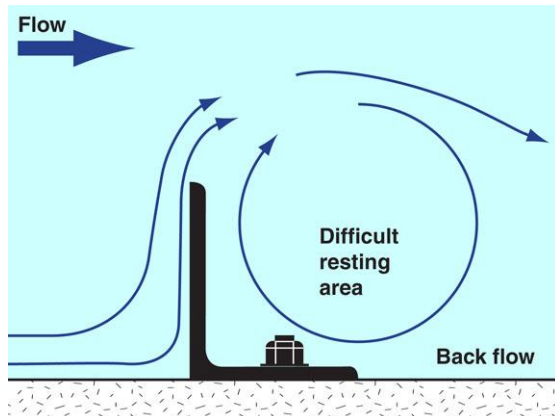


Floor baffle

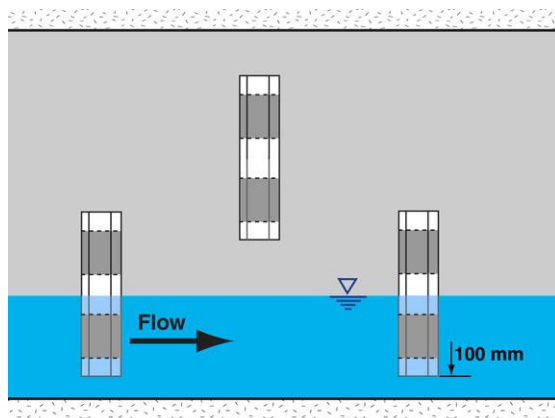
Floor-mounted baffles

- Floor-mounted baffles are used when:
 - required by legislation
 - critical fish passage is likely to occur at a set time of the year when stream flows are more likely to be minor in-bank flows
 - the culvert is located on a [clay-based](#) or [rock-based](#) waterway that does not experience significant sediment movement along the bed.

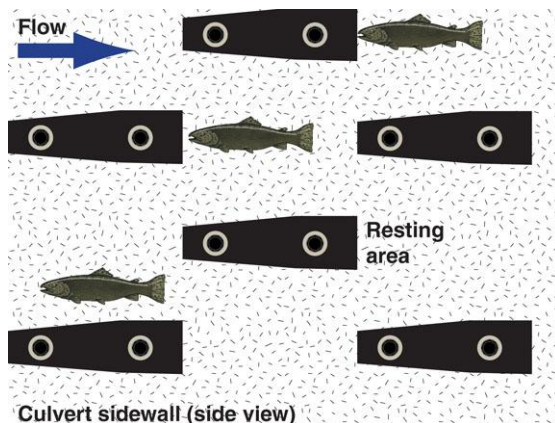
Baffle types



Section type baffle

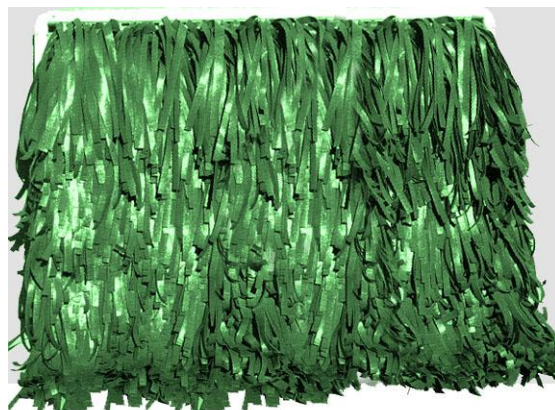


Short-length section baffles



Culvert sidewall (side view)

Sidewall roughness units



Sidewall roughness panel

1. Full-height section baffle

- Section baffles include: angle sections, Z-section, C-section (channels), and hollow box section baffles.
- These 'full length' section baffles normally extend from near the culvert floor, to near the culvert roof (obvert/soffit).

2. Short-length sidewall baffles

- The 'short-length' section baffles are usually made from the same standard section lengths, but also include pre-cast concrete and plastic units.
- These baffles do not extend the full height of the culvert, but are spaced apart, and work as a collection of individual roughness units.
- Recommended if the average flow velocity is greater than 3.5 m/s.

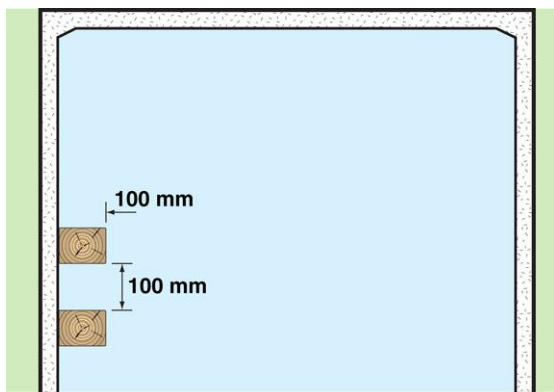
3. Sidewall roughness units (spoiler baffles)

- The intent of this system is to:
 - provide a more uniform boundary layer condition over the full sidewall
 - allow fish to always swim within the boundary layer, instead of having to burst out into the high-velocity flow in order to pass around a full height baffle
 - reduce the risk of debris blockages within side of the culvert cell.
- Recommended if velocity > 3.5 m/s.

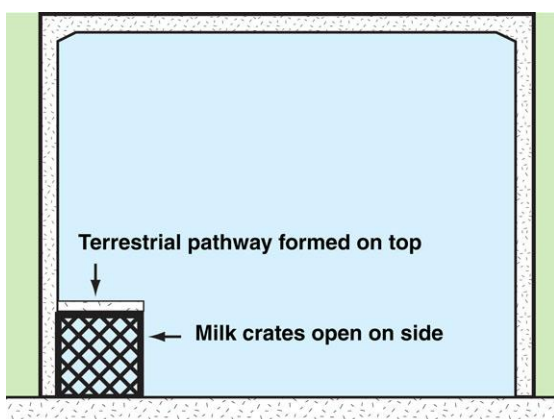
4. Sidewall roughness panels

- Sidewall roughness panels can be made from extruded plastics, as well as soft plastic strips attached to a backing board.
- The author is unaware of any fish passage trials using artificial grass, or similar.
- The intent is that the 'flapping' of the grass leaves will generate a thick boundary layer, similar to how *Lomandra* creates a zone of low velocity in natural streams.
- Designer MUST confirm the allowable use of such panels.

Baffle types



Longitudinal baffles



Milk crate pathway baffle



Corner baffles (USA)



Photo supplied by Catchments & Creeks Pty Ltd

Floor baffles (Walaman)

5. Longitudinal baffles

- Longitudinal, or horizontally-placed timber strips have been used for several years as 'lizard runs', which provide a movement pathway for smaller terrestrial wildlife that may be preyed upon if they move along a low-set dry pathway.
- The lizard runs do provide limited boundary layer development, and thus could be use by small fish, but overall their benefit to fish passage is very limited.

6. Porous modular units

- The 'milk crate' option provides the following benefits:
 - good passage for small fish
 - reduce risk of capturing large woody debris
 - can be installed on the base slab before placement of pre-cast culvert cells.
- However, this option can experience significant sediment blockage if sediment flows are likely during flood events.

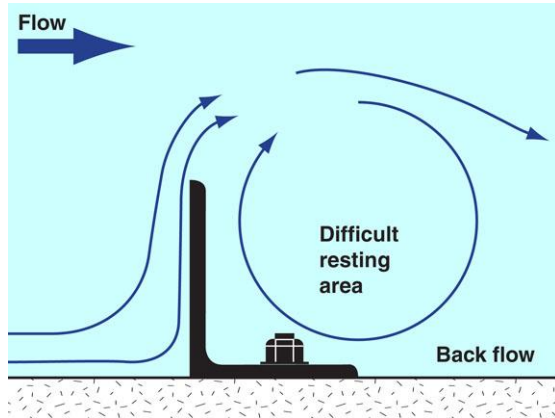
7. Corner baffles

- Corner baffles provide the following advantages:
 - good fish passage for fish that are likely to move along the channel bed.
- Corner baffles have the following disadvantages:
 - high risk of sediment blockage
 - very difficult to remove sediment blockages
 - risk of trapping large woody flood debris.

8. Floor baffles

- Floor baffles typically consist of a set of weir-type baffles offset in their longitudinal placement, often at different angles.
- Floor baffles have the following disadvantages:
 - high risk of sediment blockage
 - very difficult to remove sediment blockages
 - not suitable on gravel-based waterways.

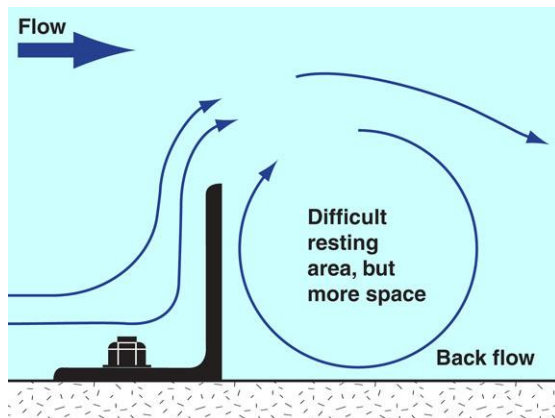
Sidewall 'section type' baffle options



Angle section (bolt downstream)

Angle section with downstream bolt

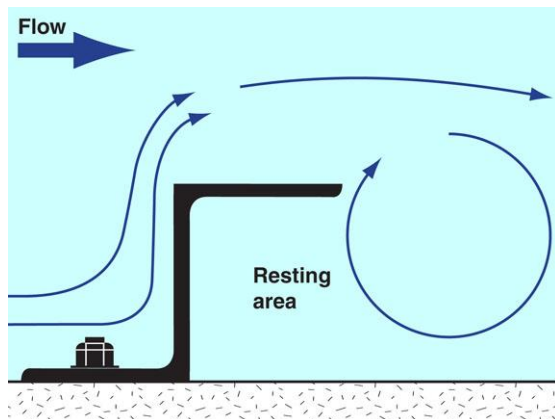
- Commercial product
- Materials: galvanised steel, stainless steel, aluminium, plastic.
- The resting area downstream of the baffle may experience significant turbulence.



Angle section (bolt upstream)

Angle section – reverse setting

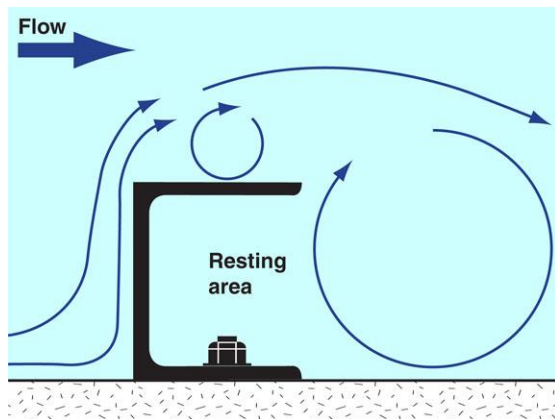
- Commercial product
- Materials: galvanised steel, stainless steel, aluminium, plastic.
- Locating the bolt on the upstream side of the baffle is unlikely to provide any benefits to fish passage because there are likely to be only two or three bolts.
- Allowing the baffle to be installed either way (i.e. flange upstream or downstream) can be beneficial during installation if the drilling process strikes a reinforcing bar.



Z-section baffle

Z-section baffles

- The direction of the approaching flow will be influenced by the spacing of the baffles.
- An area of low turbulence exists adjacent to the baffle.
- A circulating vortex can exist downstream of the baffle.
- It is believed that these baffles provide improved resting areas for fish.

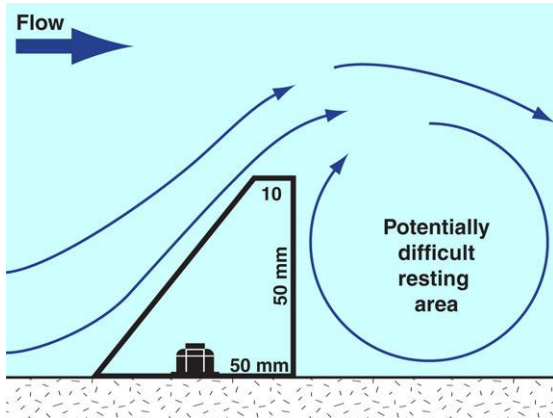


Channel baffle

Channel (C-section) baffles

- The direction of the approaching flow will be influenced by the spacing of the baffles.
- An area of low turbulence exists adjacent to the baffle.
- A circulating vortex can exist downstream of the baffle.
- Can be more difficult to attach the baffle due to the restricted access to the mounting location.

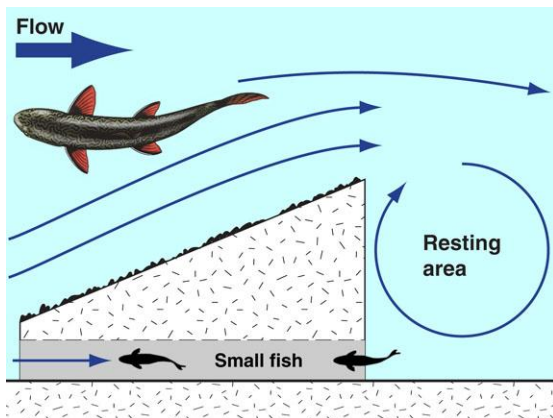
Sidewall 'section type' baffle options



Hollow box baffle

Hollow box baffle

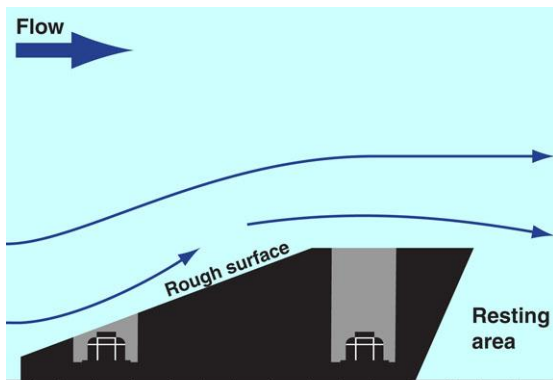
- The direction of the approaching flow will be influenced by the spacing of the baffles.
- A circulating vortex can bring high-velocity turbulence water in behind the baffle where fish would otherwise like to rest.
- Could be manufacture by extruded aluminium processes.
- Can be difficult to attach the baffle due to the restricted access to the mounting location.



Pre-cast, full-height baffle

Pre-cast, full-height baffles

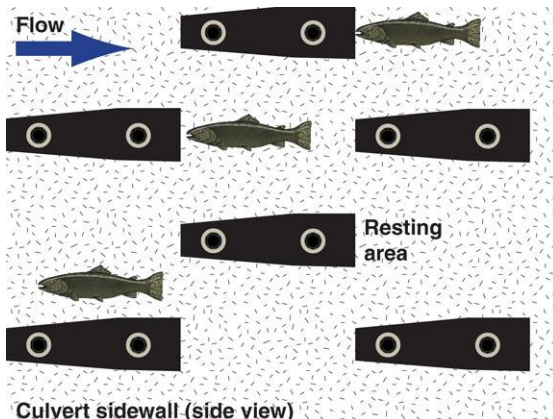
- The direction of the approaching flow will be influenced by the spacing of the baffles.
- A circulating vortex can bring high velocity turbulence water in behind the baffle where fish would otherwise like to rest.
- Potentially could provide improved passage for small fish.
- Allows off-site manufacture.



Pre-cast roughness units

Pre-cast roughness units (modular units)

- Examples shown left, below-left, and below.
- Allows fish to move in a random pattern.
- Reduced risk of trapping woody flood debris within the culvert.
- Currently (2026) limited field testing.



Culvert sidewall (side view)

Side view of a culvert sidewall



(A Photoshop-generated image)

Sidewall baffle material options



Galvanised steel (rusting)

Rusting of galvanised steel baffles

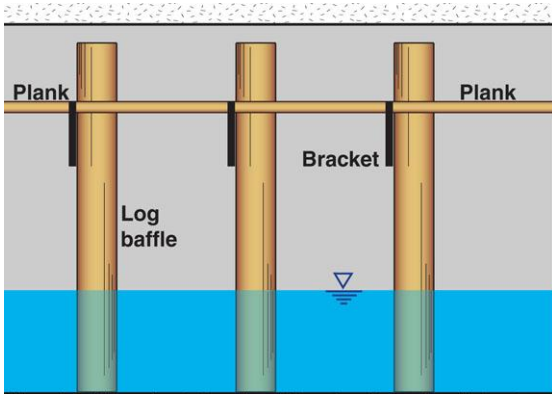
- Metal baffles can be subject to corrosion problems.
- Stainless steel is expensive, but considered better than aluminium or galvanised steel.
- Aluminium is considered better than galvanised steel.
- The problem with galvanised steel is that the sediment (sand) suspended in flood waters effectively sand-blasts away the zinc coating.



Plastic angle baffles (USA)

Plastic angle baffles

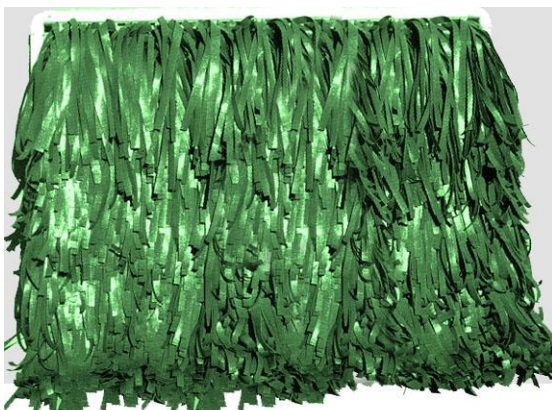
- Plastic baffles avoid the corrosion problems experienced by metal baffles.



Rusting

Treated timber logs

- Treated timber will last longer in wet areas because of its added protection, but wood rot can still occur.
- The question that the designer needs to ask is: Is it likely that the future asset manager will regularly inspect the logs, and replace them, as necessary, in order to maintain the original function of the logs?



Artificial grass panel

Artificial grass panels

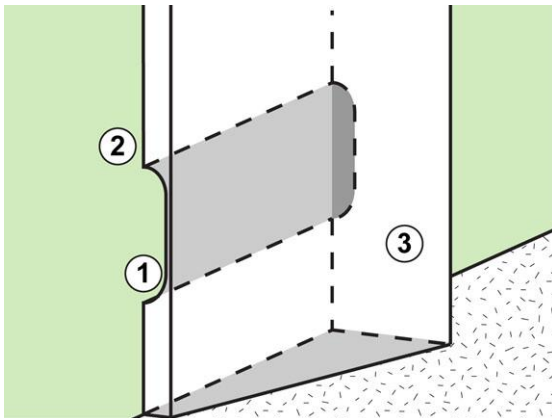
- The intent is that the 'flapping' of the grass leaves will generate a thick boundary layer, similar to how *Lomandra* creates a zone of low velocity in natural streams.

Note: Micro-plastic concerns associated with plastic-based solutions.

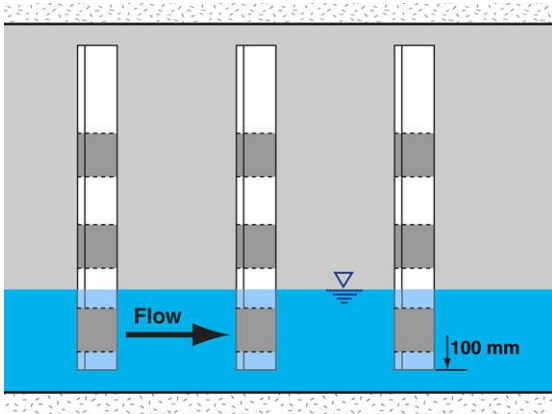
The author is unaware of this concept ever being approved or trialled in Australia.

The concept is presented here only to identify the value of boundary layer development.

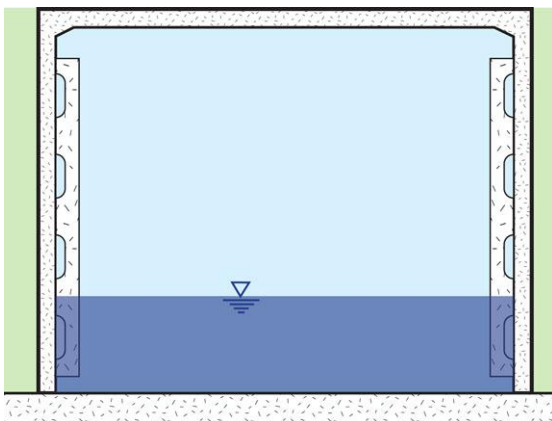
Pre-cast sidewall baffles



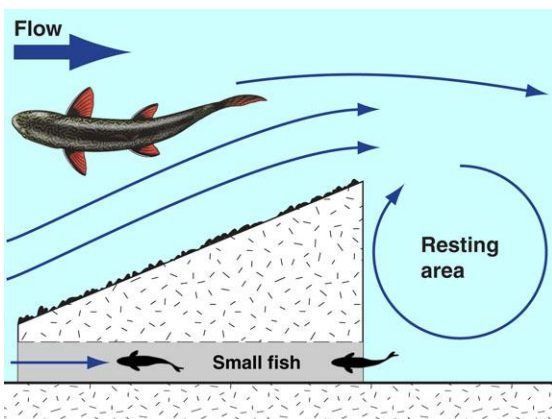
Pre-cast concrete baffle



Side view



Front view



Plan view

Introduction

- The author is unaware of any fish passage trials using such a baffle design.
- The baffle has a wedge shape to reduce the risk of trapping flood debris.
 1. Isolated, low turbulence slots aid the passage of small fish.
 2. The leading edge has the necessary thickness to make the pre-cast section durable.
 3. The downstream baffle width should, at least, match the maximum body thickness of the target species.

Attributes

- A wedge-shaped baffle will produce a thinner overall boundary layer width compared to a square-edged baffle.
- Including narrow flow slots between the baffle and the culvert sidewall could potentially assist small fish to negotiate the baffles without needing to pass around the baffles.

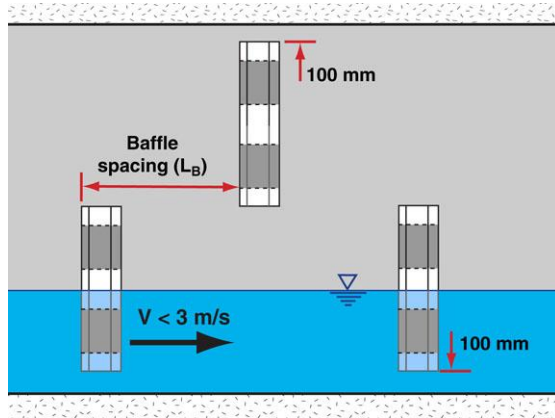
Advantages of pre-cast concrete baffles:

- Durable.
- Could provide fish passage for both small and large fish.
- Non-rusting (except for the possible fittings).

Disadvantages of pre-cast concrete baffles:

- High cost.
- The units will be heavy and difficult to install.
- Difficult to provide a suitable range of baffle lengths to match different culvert heights.

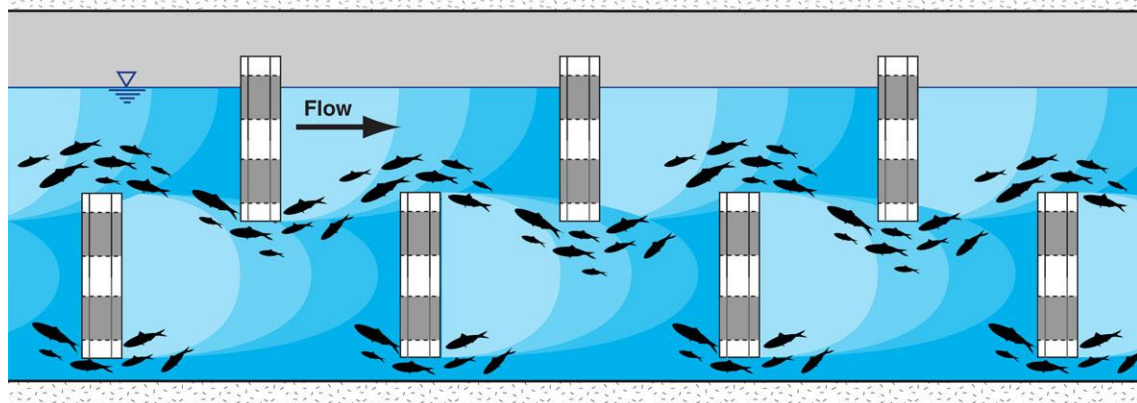
The hydraulic benefits provided by staggered baffles



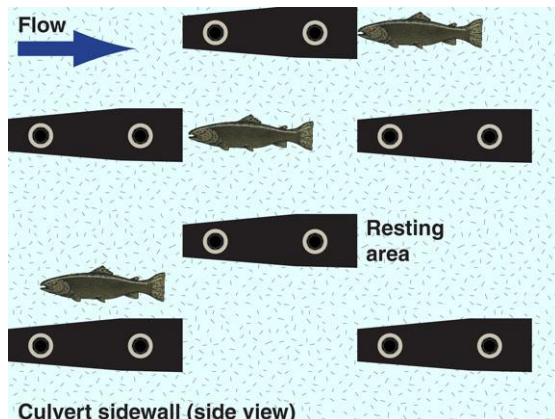
Short-length section baffles

Short-length sidewall baffles

- When fish are required to pass around a full-height baffle, they need to use their burst speed in order to enter a high-velocity region of the culvert.
- If it is accepted that fish have a burst speed of around 10BLPS (body lengths per second), then moving against flow velocities exceeding 3 m/s can be very difficult for small fish.
- Staggered baffles allow fish to swim totally within the boundary layer region that is formed adjacent to the culvert sidewall.



Low-velocity shadow zones

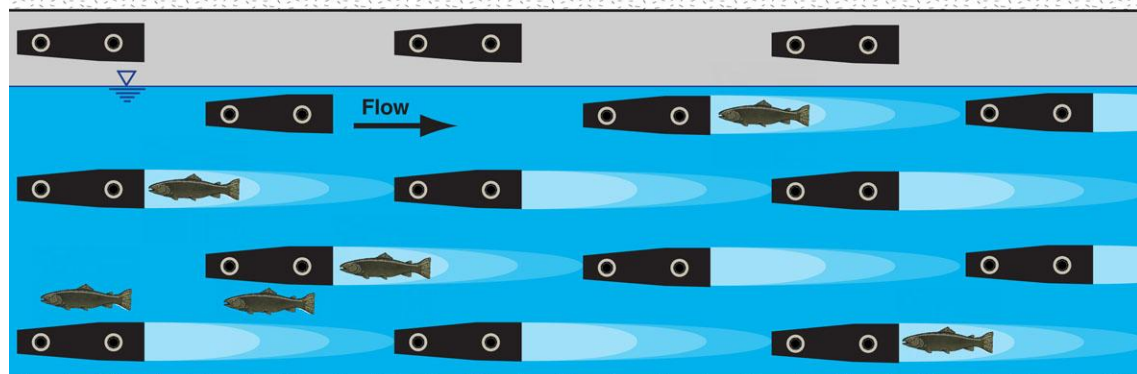


Culvert sidewall (side view)

Sidewall roughness units

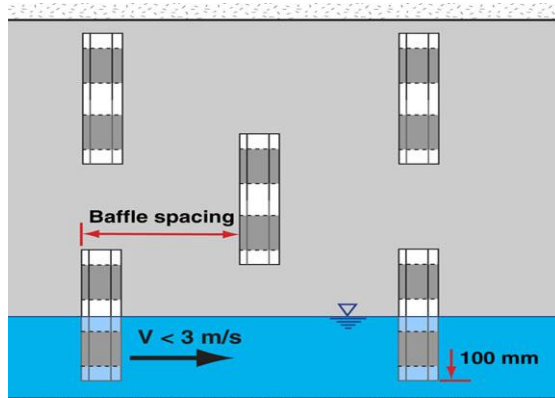
Sidewall roughness units (spoiler baffles)

- Sidewall roughness units not only allow fish to swim totally within the boundary layer region close to the sidewall, they also reduce the risk of capturing flood debris within the culvert.
- The exact location of each baffle is not critical, therefore the heavy steel reinforcing inside the culvert leg should not interfere with the attachment of each baffle.
- Also, the loss/damage of a few baffles will not cause fish passage to stop.

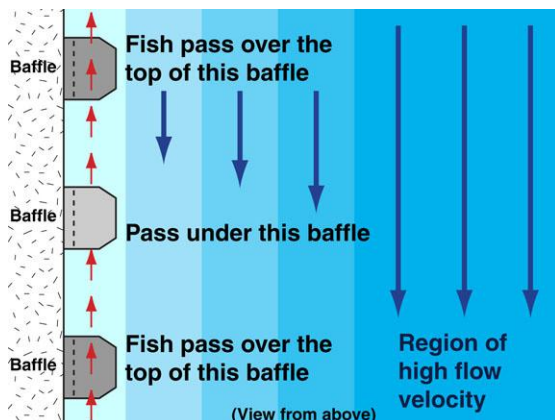


Low-velocity shadow zones

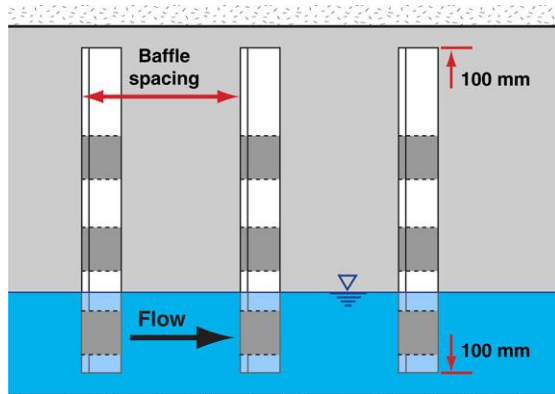
The hydraulic benefits provided by staggered baffles



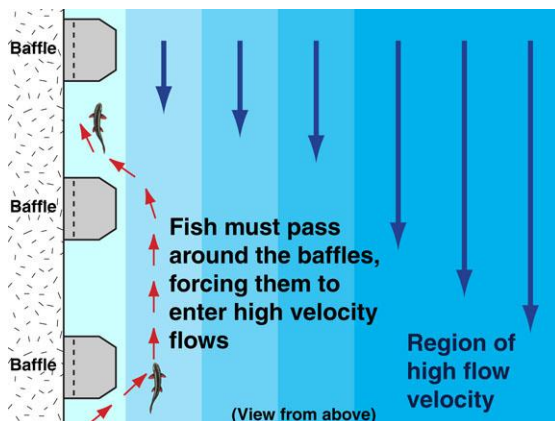
Staggered short-length baffles (side view)



Possible fish passage (top view)



Full-height baffle (side view)



Fish passage past full-height baffles (top)

Alternative positioning of baffles

- There can be a wide variety of arrangements of staggered short-length baffles depending on the height of the culvert.

Fish passage between staggered baffles

- The benefit of staggered baffles is that fish can stay within the boundary layer (and shadow zones) all the way through the culvert.
- Fish can pass over and under the short-length baffles, rather than swimming around the baffles.

Full-height baffle

- With full-height baffles, the baffles typically extend from near the bed, to near the culvert roof.

Fish passage past full-height baffles

- With full-height baffles, fish are required to move into the higher velocity zone in order to pass around the baffles.
- This means fish are required to use their burst speed, which may be insufficient if the average flow velocity in the culvert exceeds, say 3.5 m/s.

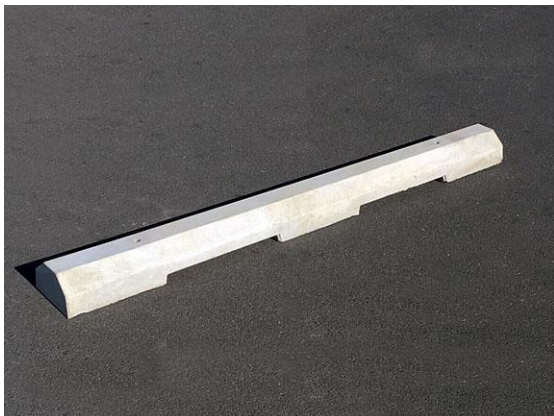
Pre-cast parking stops (lateral thinking)



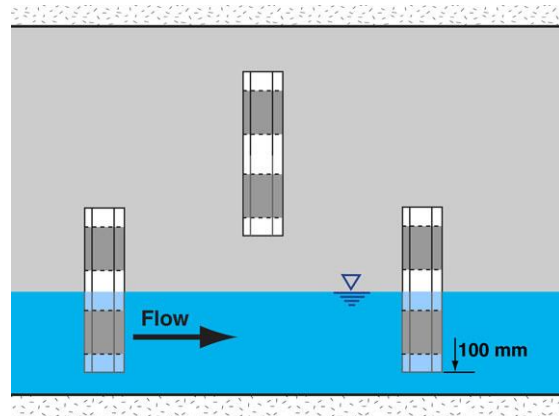
Absolute Concrete

Making use of existing pre-cast concrete units

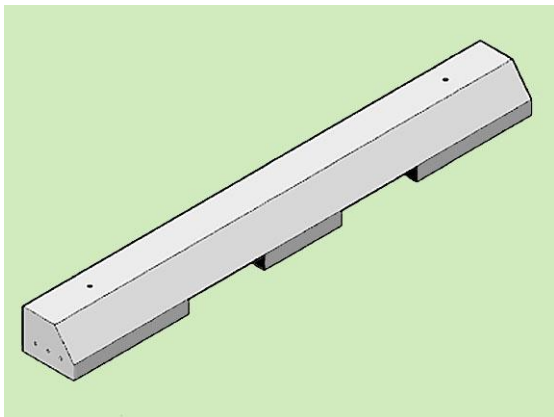
- Numerous existing pre-cast concrete traffic control units can do the equivalent job of sidewall baffles.



Bundaberg Concrete Casting



Typical placement along a sidewall



Cromwell Concrete



Enforcer Group Concrete Wheel Stop



Turner Vault Concrete Parking Stop



Wilbert Precast Inc.

Log baffles



Photo supplied by Catchments & Creeks Pty Ltd

Fauna tunnel (NSW)



Photo supplied by Catchments & Creeks Pty Ltd

Floodplain culvert (NSW)

Introduction

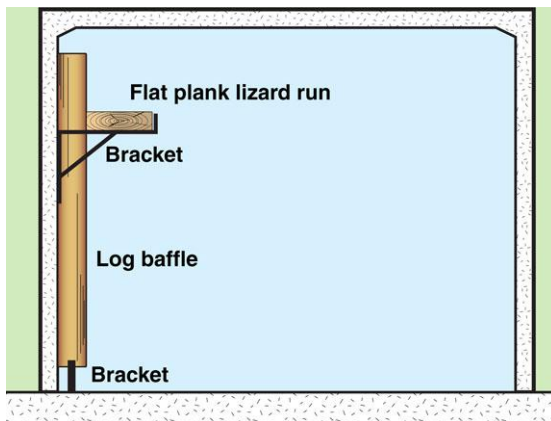
- Log type culvert 'furniture' is more commonly used in **fauna tunnels** that are located away from waterways (e.g. floodplain culverts).

Sidewall baffles

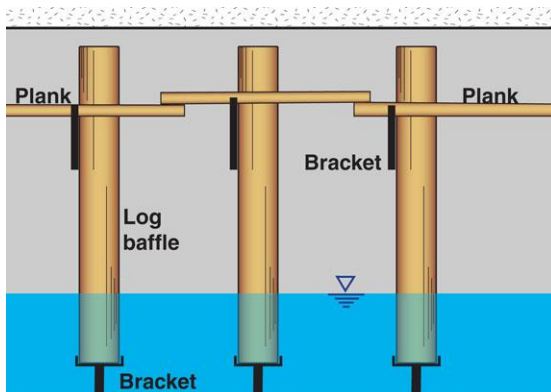
- For floodplain culverts, fish passage may still be an issue.
- Treated timber logs can be used as sidewall baffles.

Installation

- Choosing a readily available commercial bracket size can allow good integration of the vertical log baffles and the horizontal lizard run.
- Use of a floor bracket (cradle) reduces the need to drill into the heavily reinforced culvert legs.



Cross-sectional view

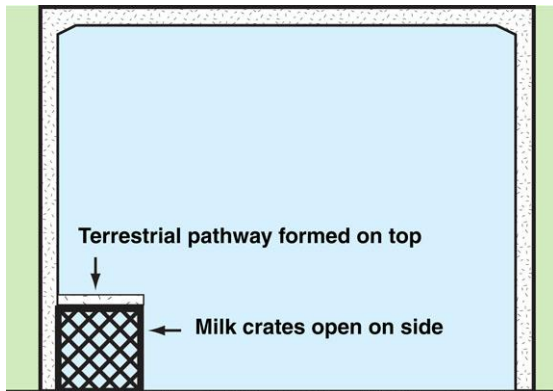


Side view

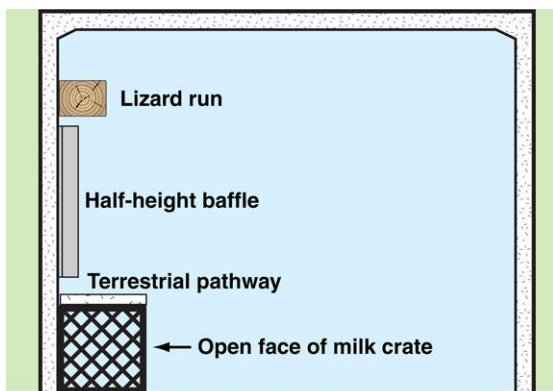
Spacing

- Spacing depends on the diameter of the logs:
 - Six (6) times the baffle width for 100 mm poles
 - Five (5) times the baffle width for 200 mm or greater logs.

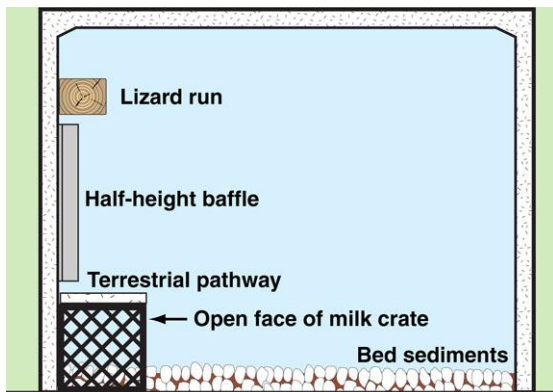
Milk crate baffles (questionable usage)



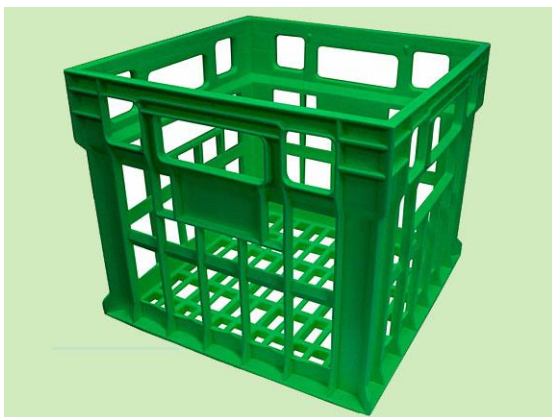
Milk crate baffle with terrestrial pathway



Milk crate baffle and lizard run



Crate, baffle, lizard run & bed roughness



Milk crate

Milk crate corner baffle

- This concept has been presented as a design option for small owner-built (private) culverts.
- The intent is to provide:
 - elevated terrestrial passage (must be set above dry-weather flow height)
 - increased passage for small fish
 - increased boundary layer thickness along the side of the baffle for medium-sized fish.
- Not suitable for alluvial waterways.

Advantages of milk crate baffles:

- Advantages are:
 - allows for separate movement of small and large fish
 - cheap to purchase
 - cheap to install
 - can be attached to the culvert sidewall (leg) or the culvert floor
 - can be attached to the culvert in several different ways
 - allows for the integration of a terrestrial pathway
 - the crates protect fish from terrestrial/arboreal predators
 - the crates potentially provide better resting areas because of the flow passing through the upstream face
 - cheap and easy to replace.

Disadvantages of milk crate baffles:

- Disadvantages are:
 - sediment will collect within the crates
 - sediment will be difficult to wash out of the crates.

Milk crate baffles

- NOT SUITABLE for culverts located on sand-based or gravel-based (alluvial) waterways that are likely to experience significant bed load.

Note: The author is unaware of this concept ever being trialled or approved for use.

The concept has been presented as an option for small owner-built culverts where construction cost is a critical factor.

Floor baffles



Block-ramp fishway (Walaman)



Chevron baffles at culvert inlet



Baffled fishway



Notched baffles (USA)

Block-ramp fishways

- A constructed fishway formed from pre-cast units, which simulates the operation of a ridge-rock or pool-riffle system.
- NOT SUITABLE for culverts located on [sand-based](#) or [gravel-based](#) (alluvial) waterways that are likely to experience significant bed load.

Chevron baffles

- Regularly-spaced, low-level floor baffles formed in a V-shape (chevron) typically pointing upstream to focus turbulence and flow energy towards the centre of the channel.
- Questionable application on [sand-based](#) or [gravel-based](#) (alluvial) waterways that are likely to experience significant bed load.

Fishways

- These fishways usually do not experience sedimentation problems when located on a dam or weir because the bed load is captured by the dam or weir.
- However, when used as part of a culvert fishway, sediment deposition is likely to be a major problem.

Notched baffles

- A weir-baffle that contains a 'notch' in the weir crest from which water discharges at a greater depth compared to the rest of the weir.
- During periods of low flow, fish passage may be restricted to just the width of the notch.

Floor baffles



Photo supplied by Catchments & Creeks Pty Ltd

Offset baffles (Walaman)

Offset baffles

- A set of weir-baffles offset in their longitudinal placement, often at different angles.
- NOT SUITABLE for culverts located on [sand-based](#) or [gravel-based](#) (alluvial) waterways that are likely to experience significant bed load.



Photo supplied by Catchments & Creeks Pty Ltd

Ridge-block fishway (Walaman)

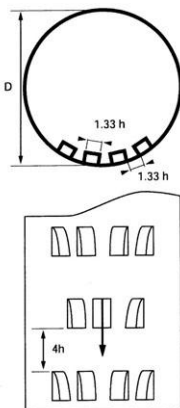
Ridge-block fishways

- A fishway formed from pre-cast units that simulates a ridge-rock fishway or riffle system.
- NOT SUITABLE for culverts located on [sand-based](#) or [gravel-based](#) (alluvial) waterways that are likely to experience significant bed load.



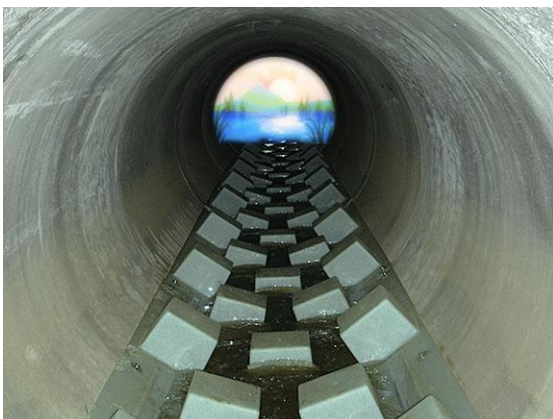
Diagram by Larinier, 2002

Spoiler baffles



Spoiler baffles

- A fishway formed from streamline, near-rectangular, pre-cast or cast in-situ, baffles attached to the bed of a channel or culvert.
- NOT SUITABLE for culverts located on a [sand-based](#) or [gravel-based](#) (alluvial) waterway that are likely to experience significant bed load.

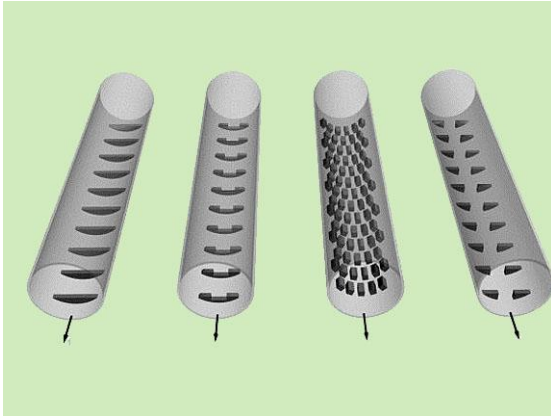


Spoiler baffles

Spoiler baffles (alternative design)

- NOT SUITABLE for culverts located on [sand-based](#) or [gravel-based](#) (alluvial) waterways that are likely to experience significant bed load.

Floor baffles



Spoiler baffles



Spoiler baffle



Photo supplied by Queensland Fisheries

Slotted weir-type baffle (Tim Marsden)



Flexible weir floor baffle (USA)

Spoiler baffles

- NOT SUITABLE for culverts located on [sand-based](#) or [gravel-based](#) (alluvial) waterways that are likely to experience significant bed load.

Spoiler baffles

- NOT SUITABLE for culverts located on [sand-based](#) or [gravel-based](#) (alluvial) waterways that are likely to experience significant bed load.

Slotted weir-type baffles

- NOT SUITABLE for culverts located on [sand-based](#) or [gravel-based](#) (alluvial) waterways that are likely to experience significant bed load.

Flexible weir floor baffles

- NOT SUITABLE for culverts located on [sand-based](#) or [gravel-based](#) (alluvial) waterways that are likely to experience significant bed load.

Floor baffles

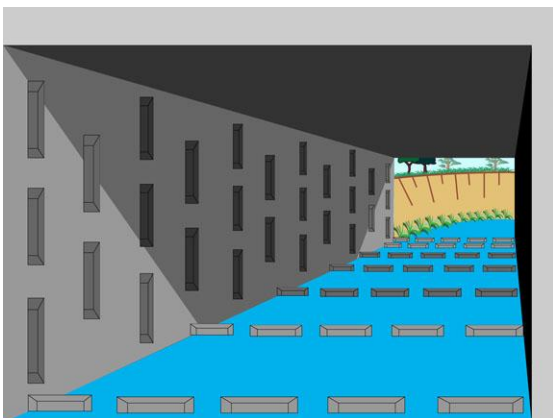


Photo supplied by Catchments & Creeks Pty Ltd

Sediment deposition (USA)

Retention of natural bed sediments

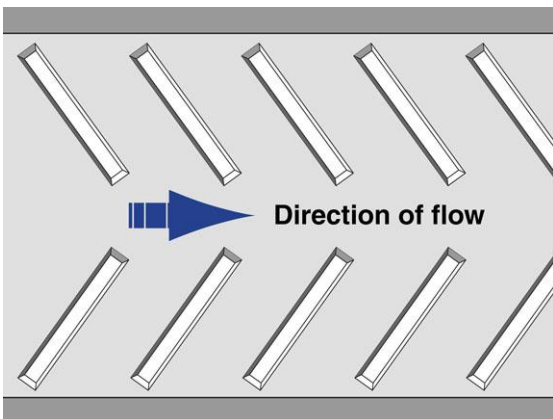
- Floor baffles can be used in low sediment waterways to provide resting zones for fish that prefer to move along the channel bed.
- However, it is essential for the floor baffle to be compatible with the needs of the fish, the behaviour of the waterway, and the needs of the asset manager.
- Most waterways experience some degree of sediment flow, especially during floods.



Floor baffles (perspective view)

Floor baffles used to aid fish passage along the culvert floor

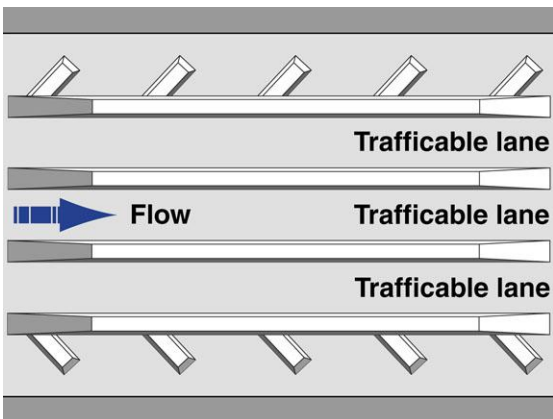
- Floor baffles are typically 100 to 200 mm high.
- Typical spacing of floor baffles is six (6) times the baffle height.
- Consideration can be given to the use of commercial pre-cast 'parking stops' (as shown on a previous page).



Floor baffle arrangement (plan view)

Floor baffles used to aid the retention of bed sediments to form 'natural' bed conditions

- Floor baffles are typically 100 to 200 mm high.
- Placing the baffles on an angle to the direction of flow can aid in the jet washing (maintenance) of the culvert after a flood event.
- Typical spacing of floor baffles is six (6) times the baffle height.

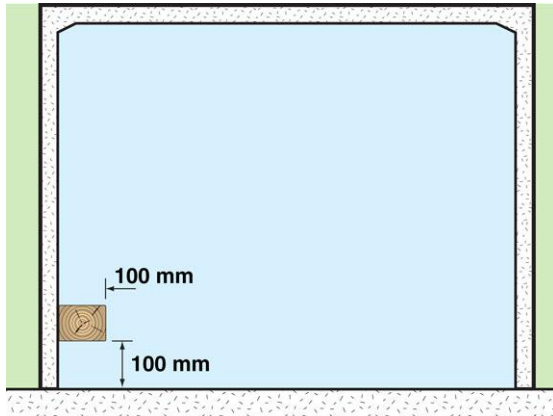


Floor baffle arrangement (plan view)

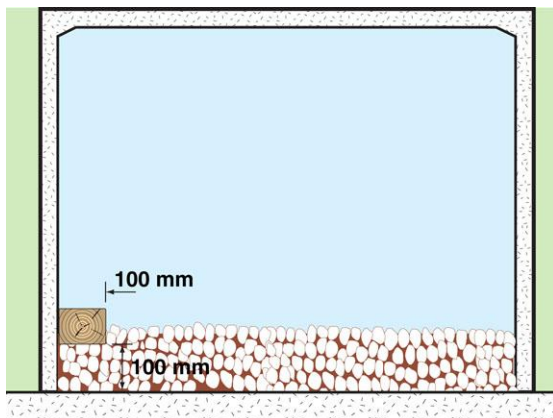
Floor baffles that assist post-flood de-silting operations

- If the culvert is large enough to allow mechanical equipment to enter the culvert for the purpose of clearing away excess sediment and flood debris, then:
 - the floor baffles should be arranged in a manner that would allow a skid-steer loader to manoeuvre over the baffles for the purpose of collecting, or pushing, any trapped sediment.
- The baffle arrangement must be based on the likely maintenance equipment.

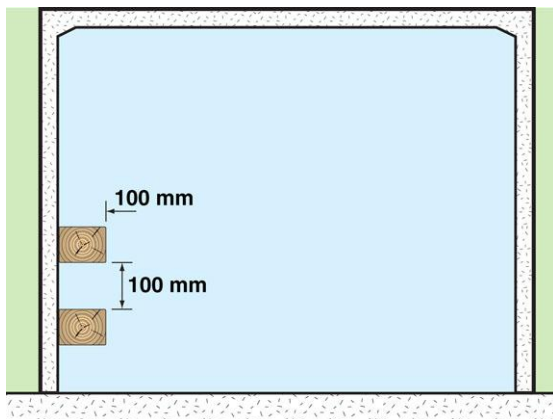
Longitudinal box baffles



Culvert cross-section



Impact of sediment deposition



Potential solution to a sediment problem



Photo supplied by Catchments & Creeks Pty Ltd

Terrestrial passage culvert cell (Qld)

Lizard run

- This technique uses the terrestrial passage 'lizard run' to provide an increase in boundary layer thickness
- The longitudinal box baffle is an outcome of the [University of Queensland](#) flume testing.
- The concept is based on the favourable boundary layer conditions that develop within a three-sided confined space.

Advantages of a longitudinal box baffle

- Advantages are:
 - lower cost compared to vertical baffles
 - significantly reduced risk of debris blockage
 - low risk of damage during flood events.

Disadvantages of a longitudinal box baffle:

- Disadvantages are:
 - the system currently does not provide resting areas, so the system may not work in long culverts
 - the effectiveness of the system is potentially more dependent on the flow velocity within the culvert than would be the case of vertical baffles (this could mean that the system fails during high velocity)
 - the system is highly susceptible to sediment deposition
 - the system may not benefit larger fish
 - it is likely that vertical baffles would still be required within the culvert.



Photo supplied by Catchments & Creeks Pty Ltd

Do not start or end in middle of culvert

E2 - The Needs of the Waterway



Raising a concern

Introduction

- So, why do we need to consider the needs of the waterway?
- Because, if we don't, it could mean:
 - a significant increase in the cost of post-flood maintenance (de-silting) of the culvert—a human cost
 - a significant decline in post-flood fish passage if the baffles are not cleared of debris or sediment blockage—an environmental cost
 - a blockage of the natural bed migration.



Photo supplied by Catchments & Creeks Pty Ltd

Sediment flow through a culvert (Qld)

Critical waterway characteristics

- Waterway characteristics that are likely to influence a baffle design include:
 - tidal or non-tidal waterways
 - fish habitat rating (waterway ranking)
 - the bed conditions of the waterway
 - the type and location of bank vegetation
 - whether or not the waterway has a floodplain—in such cases, fish may approach the road culvert swimming along the floodplain.

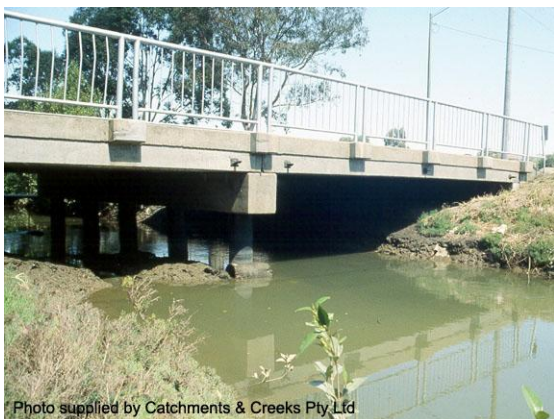


Photo supplied by Catchments & Creeks Pty Ltd

Black mud under a tidal bridge (Qld)

Tidal and non-tidal waterways

- In tidal estuaries with medium to high turbidity, each tidal cycle can deposit a thin layer of fine silt on the bed of waterway culverts.
- Often, this material contains fine organic matter, which can make the settled sediment highly cohesive, thus preventing it from being washed away each tidal cycle, or even during flood events.
- Such sediment is often found under tidal bridges, as well as within culverts.

The natural migration of bed material



Photo supplied by Catchments & Creeks Pty Ltd

Clay-based waterway (Townsville, Qld)

Clay-based waterways

- Clay-based waterways are often referred to as fixed-bed waterways because, in their natural state, they may not experience significant migration of bed material.
- However, in urban areas, these waterways can experience high sediment flows due to the sediment runoff from urban development.



Photo supplied by Catchments & Creeks Pty Ltd

Sand-based waterway (Bundaberg, Qld)

Sand-based waterways

- Sand-based waterways can experience significant movement of the sandy bed material during both wet years and dry years.
- The sand can easily smother bed baffles.
- The sand can be flushed out by high-velocity flows, but most flood events end with a period of low-velocity flows that can simply replace the earlier displaced sediment.



Photo supplied by Catchments & Creeks Pty Ltd

Gravel-based waterway (Eungella, Qld)

Gravel-based waterways

- Gravel-based waterways can experience significant movement of the gravelly bed material during major and extreme flood events.
- During minor floods there may not be significant bed movement.
- Once this bed material smothers any bed baffles, they can only be removed by physical extraction, one-by-one.



Photo supplied by Catchments & Creeks Pty Ltd

Rock-based waterway (Spicers Creek, Qld)

Rock-based waterways

- Solid rock-based waterways can experience significant movement of bed material if the rocky reaches of the waterway are separated by sand-based or gravel-based reaches.

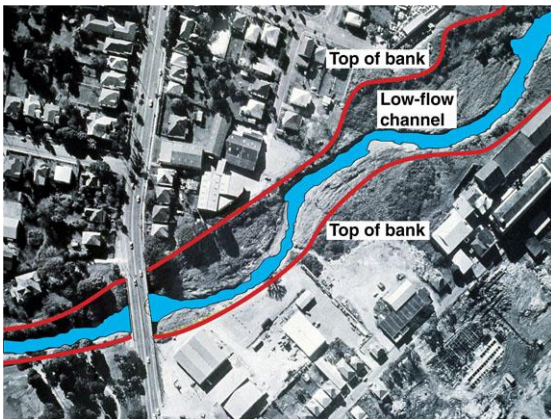
Lateral movement of the low-flow channel



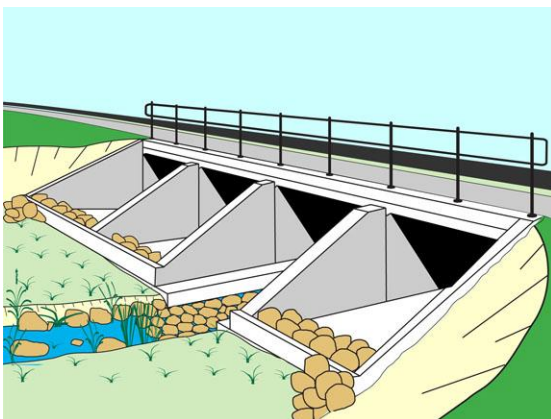
Low-flow channel in a gravel-based creek



Braiding channel (Qld)



Meandering low-flow channel (Qld)



Culvert with low-flow cell

Introduction

- The low-flow channel is the portion of a waterway bed that contains the low-flow, or base flow, that cannot be directly attributed to recent storms.
- These low flows include any regular, long-term inflows such as environmental flows from regulated lakes or reservoirs.
- The flow rate is usually not constant throughout the year, and typically varies with groundwater levels and long-term weather conditions.

Braiding channels

- A braided channel has multiple low-flow channels separated by small mid-channel bars or small islands.
- The use of culverts may not be suitable for such channels.
- The bed width of the main channel is wide, which means bridge crossings are normally preferred.
- A braided channel may have more than one main channel.

Meandering low-flow channels

- In a natural system, the main channel can meander across the bed of a wide valley, and the low-flow channel can meander across the bed of the main channel.
- If a multi-cell culvert crosses a wide channel that has a meandering low-flow channel, then:
 - nominating one of the cells as the low-flow channel is **unlikely** to adversely affect the natural function of the channel away from the culvert.

Low-flow cells

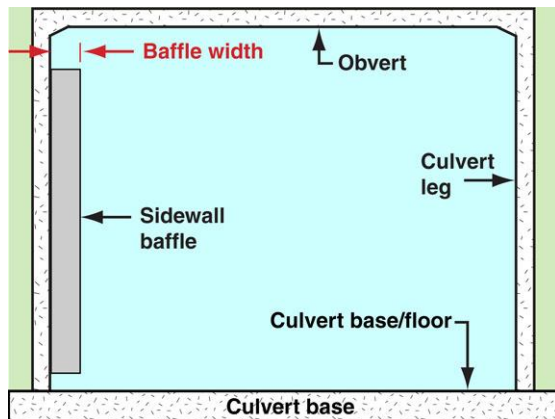
- If one or more cells in a multi-cell culvert are nominated as 'wet' cells, then:
 - the full width of each wet cell may be treated as the low-flow channel (meaning the full bed width of these cells is set below the natural bed), or
 - a well-defined low-flow channel may be formed along the bed of one of the wet cells.
- In the latter case, the low-flow channel should be the same width as, and align with, the natural low-flow channel.

E3 - The Needs of Fish

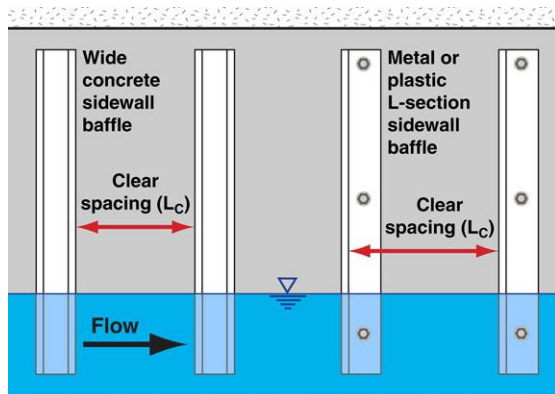


Photo supplied by Catchments & Creeks Pty Ltd

Sidewall baffles (NSW)



Baffle depth



Baffle clear spacing

Introduction

- Designers should not think of baffles and bed roughness as a means of controlling flow velocities.
- Sidewall baffles are used as a means of simulating **natural bank roughness**, and the benefits this roughness provides to boundary layer development, and consequently, fish passage.
- Bed roughness is used as a means of simulating **natural bed roughness**.

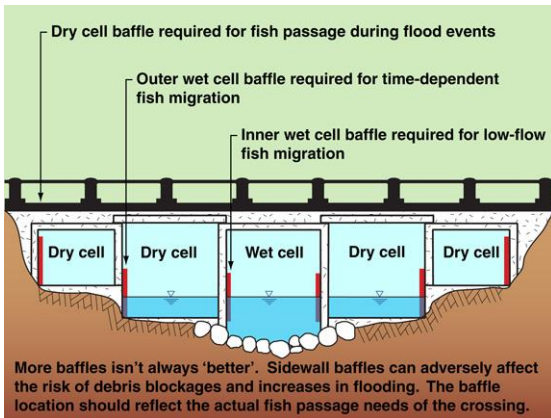
Baffle width

- The width of a sidewall baffle (i.e. its protrusion from the sidewall) should be at least equivalent to the maximum 'body thickness' of the target species.
- Typical depth (k) is 100 to 200 mm.

Baffle clear spacing (L_c)

- The spacing of sidewall baffles should be:
 - Six (6) times the baffle width for baffle widths less than 100 mm
 - Five (5) times the baffle width for baffle widths less than 200 mm
 - Five (5) times the baffle width for baffle widths greater than, or equal to 200 mm, and flow velocity less than 2 m/s.
 - Four (4) times the baffle width for baffle widths greater than, or equal to 200.
 - Four (4) times the baffle width on the culvert wingwalls.

Design issues relating to the needs of the fish



Cross-section of multi-cell culvert

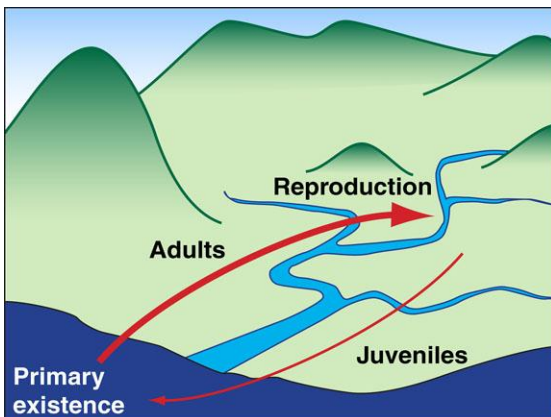


Baffles placed on a culvert wingwall (Qld)



Photo supplied by Catchments & Creeks Pty Ltd.

Lunching at a culvert fishway (Qld)



Anadromous fish movement

Baffle location in multi-cell culverts

- In multi-cell culverts, it is likely that baffles will only be required along the sidewalls located immediately adjacent to the waterway banks.
- Variations in this requirement may occur if fish passage is expected at water levels that do not adequately 'wet' the outer cells of the culvert.
- For example, if fish migrate at a set time of year, independent of the flow rate, then baffles may be required in the 'wet' cells.

Baffles placed on wingwalls

- Special consideration must be given to the placement of baffles on wingwalls, both upstream and downstream of the culvert.
- The author cautions the placement of baffles only on those wingwalls that form a region of flow **contraction**, whether upstream or downstream of the culvert.
- The suggested baffle spacing is four (4) times the baffle width on the wingwalls.

Fishways should not become a lunchroom for other wildlife

- Consideration must be given to the risk of fish loss by predatory waterbirds that may take advantage of fish movement along a confined fishway.
- This does not mean that a fishway should not be constructed; but simply that all reasonable and practicable measures should be taken to minimise the unnatural loss of fish stocks (if possible).

Design issues influenced by the timing of fish passage

- Consideration must be given to the types of baffles required to assist fish passage during:
 - periods of low flow (i.e. daily movement)
 - periods when fish migration is linked to a given time of year (if any)
 - periods when fish migration is triggered by flood events (if any).

E4 - The Needs of Terrestrial Fauna



Photo supplied by Catchments & Creeks Pty Ltd

Elevated (dry) terrestrial pathway (Qld)



Photo supplied by Catchments & Creeks Pty Ltd

Lizard run and terrestrial pathway (Qld)

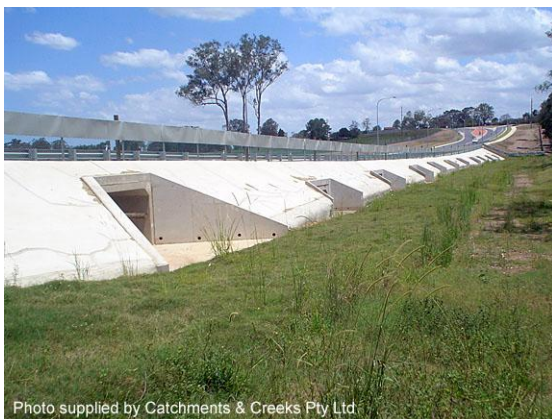


Photo supplied by Catchments & Creeks Pty Ltd

Floodplain culverts (Qld)

Introduction

- The policies and focus of any Fisheries office, or any fish passage guideline, cannot be limited to just the consideration of aquatic life.
- All agencies, and all designers, have a duty of care to consider the wider impact of their policies or designs on the greater environment, which includes terrestrial wildlife (terrestrial passage).

Note: All state officers must comply with all state legislation.

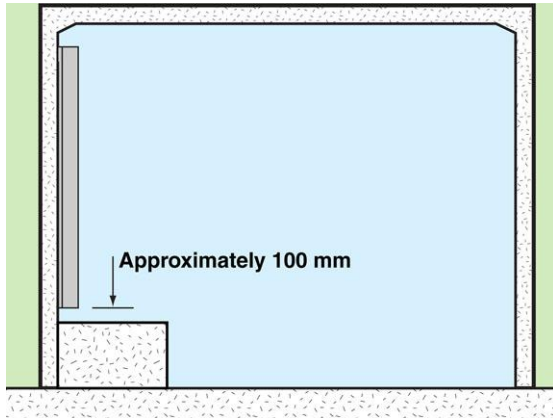
'Wet' and 'dry' movement paths

- **Fish passage**, at least in Australia, typically requires a water depth that exceeds the body-depth of the fish; however, fish can negotiate short distances on the side of their body.
- Most **native terrestrial passage** requires a 'dry' pathway (exceptions do exist).
- Thus, the terrestrial passage must exist above the normal dry-weather water level, and sidewall baffles should not reduce the width of the dry path from the specified minimum requirements.

Floodplain culverts

- Fauna passage culverts are often located away from waterways (i.e floodplain culverts, or fauna tunnels).
- These culverts provide dry terrestrial passage under major roadways where road-kill would be a major concern.
- If the fauna tunnels are located away from the waterway, then fish passage baffles may not exist.
- However, if fish passage occurs along the floodplain, then sidewall baffles may be required in these floodplain culverts.

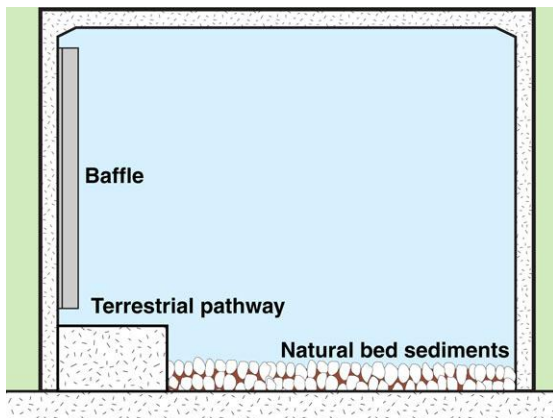
Integration of aquatic and terrestrial passage features



Single sidewall baffle

Basic design

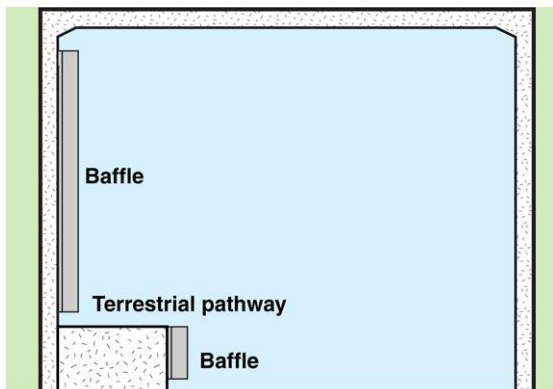
- Terrestrial pathways can be integrated into fish-friendly culverts.
- 'Dry' terrestrial pathway set above dry-weather flow.
- Minimum clear path width of 300 mm.
- Desirable clear path width of 500 mm in culvert cells at least 1800 mm wide.



Natural bed sediment

Inclusion of natural or introduced bed roughness

- The elevation of the 'dry' pathway must take into account the hydraulic effects of added bed roughness.



Baffles attached to the terrestrial pathway

Baffles placed on the side of the dry pathway

- If fish passage is expected during periods of zero flow or low flow, and bed roughness is not included, then consideration should be given to the placement of baffles on the side of the 'dry' fauna pathway.



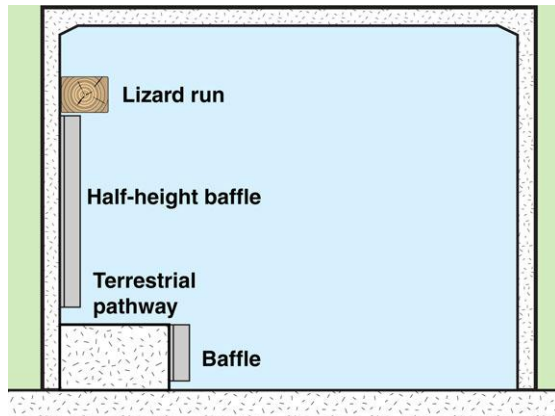
Photo supplied by Catchments & Creeks Pty Ltd

Baffles attached to the terrestrial pathway

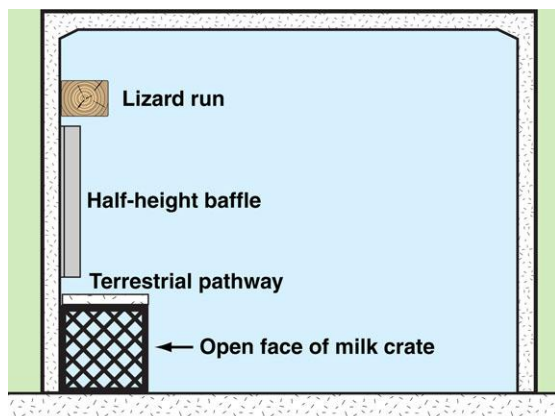
Example

- An example of baffles placed on the side of the dry fauna pathway.

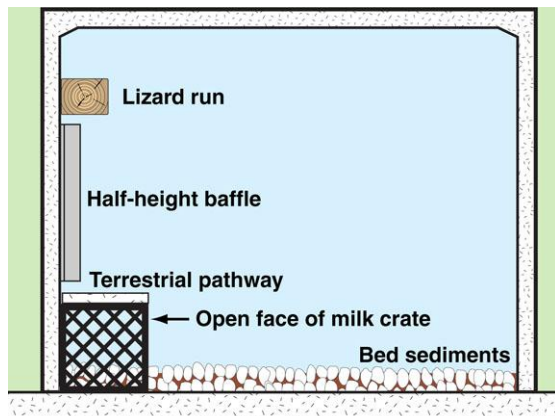
More complex designs



Half-height baffle with lizard run



'Milk crate' fishway option



Milk crate with bed roughness



Photo supplied by Catchments & Creeks Pty Ltd.

Lizard runs and roughened culvert bed

Lizard runs

- Lizard runs are used for the passage of small fauna that need to be separated from larger predators.
- Lizard runs are also considered to aid in boundary layer development and the passage of small fish during flood events.

Milk crate baffles

- The 'milk crate' corner baffle has been developed to allow the use of existing cheap, mass-produced products.
- NOT SUITABLE for culverts located on [sand-based](#) or [gravel-based](#) (alluvial) waterways that are likely to experience significant bed load.

Advantages of milk crate baffles:

- Advantages are:
 - allows for separate movement of small and large fish
 - cheap to purchase
 - cheap to install
 - can be attached to the culvert sidewall (leg) or the culvert floor
 - can be attached to the culvert in several different ways
 - allows for the integration of a terrestrial pathway
 - the crates protect fish from terrestrial/arboreal predators
 - the crates potentially provide better resting areas because of the flow passing through the upstream face
 - cheap and easy to replace.

Disadvantages of milk crate baffles:

- Disadvantages are:
 - sediment will collect within the crates
 - sediment will be difficult to wash out of the crates.

E5 - The Needs of the Community

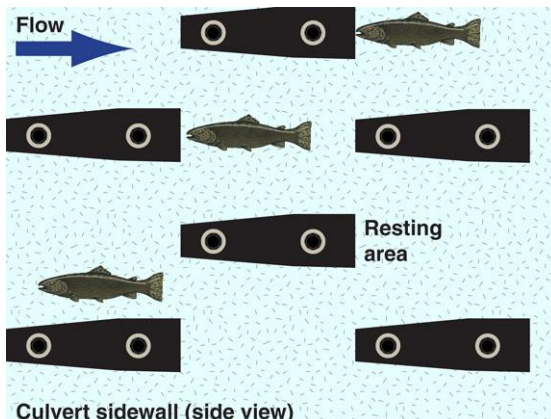


Photo supplied by Catchments & Creeks Pty Ltd

Local community (Qld)

Introduction

- The design and use of sidewall baffles can potentially impact the local community in the following ways:
 - improved fish communities, which results in improved fishing and fish consumption
 - adverse flooding at culverts
 - increased cost of culvert design and construction
 - increased cost of ongoing culvert maintenance.



Culvert sidewall (side view)

Side view of a culvert sidewall

Flood control

- The **flood risk** attributable to the use of sidewall baffles can be reduced by:
 - reducing the number of baffles
 - limiting the number of cells in a multi-cell culvert that are required to have sidewall baffles
 - using flexible baffles, such as baffles made from stiff, but not 'hard' plastics
 - using pre-cast concrete roughness units (modular units) instead of tall solid baffles.



Similar concept placed on the bed

Financial issues

- The **financial cost** attributable to the use of sidewall baffles can be reduced by:
 - adopting standard designs
 - reducing the number of baffles
 - limiting the number of cells in a multi-cell culvert that are required to have sidewall baffles
 - using flexible baffles, such as baffles made from stiff, but not 'hard' plastics
 - using pre-cast concrete roughness units (modular units).

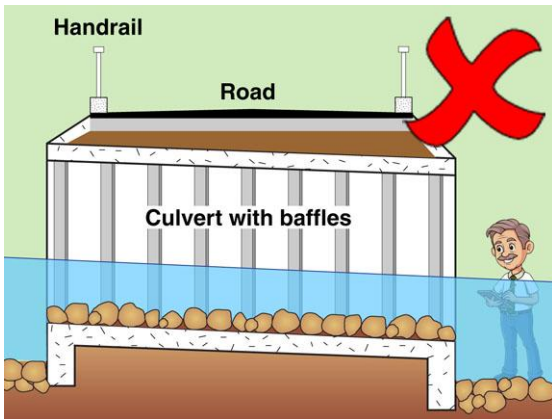
E6 - The Needs of the Asset Manager



Council building (NSW)

Introduction

- Asset managers must, of course, consider the needs of the community, as well as all state legislation.
- Design issues that can affect the activities of asset (culvert) managers include:
 - worker's safety during site inspections
 - worker's safety during maintenance
 - cost of de-silting and post-flood debris removal
 - cost of replacing damaged baffles.



Unsafe maintenance inspection conditions

Workplace health and safety issues

- Design issues linked to workplace safety include:
 - safe footing at culvert entrance and exit—usually provided by a concrete apron which provides a stable surface with good surface friction
 - safe access inside the cell containing baffles in order to remove debris and replace baffles—usually requires consideration of a confined workspace and associated safety legislation.



Woody debris (NSW)

Access issues and maintenance costs

- Design issues linked to site access and maintenance costs include:
 - safe access to the culvert inlet and outlet
 - safe access into the culvert cells
 - frequency of debris removal
 - difficulty of sediment removal (use of machinery, or hand operations)
 - cost and frequency of baffle replacement
 - design life of baffles.

Attributes of various baffle materials

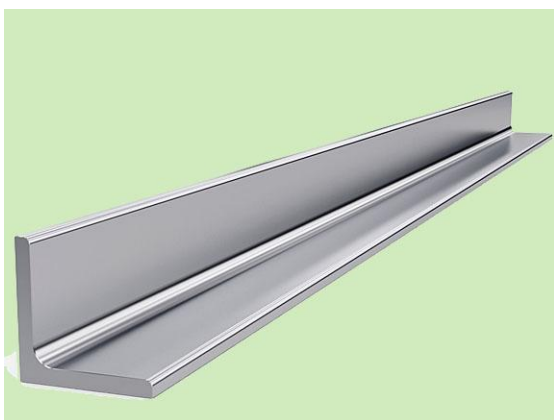


Photo supplied by Catchments & Creeks Pty Ltd

Rusted galvanised steel baffles (NSW)

Galvanised steel

- Metal baffles can be subject to corrosion problems.
- The problem with galvanised steel is that the sediment (sand) suspended in flood flows effectively sand-blasts the zinc coating.
- It is noted that the rusted state of the baffles shown here will still provide the same degree of fish passage benefits, even with the rust holes in the metal.



Stainless steel

Stainless steel

- Stainless steel is expensive, but considered better than aluminium or galvanised steel.



Aluminium

Aluminium

- Aluminium is considered better than galvanised steel.
- Aluminium baffles are likely to be more easily damaged by flood debris.



Plastic angle baffles (USA)

Plastic

- The author is unaware of field trials on plastic baffles.
- The design life of plastic baffles can be highly variable depending on the type of plastic and the thickness of the plastic.

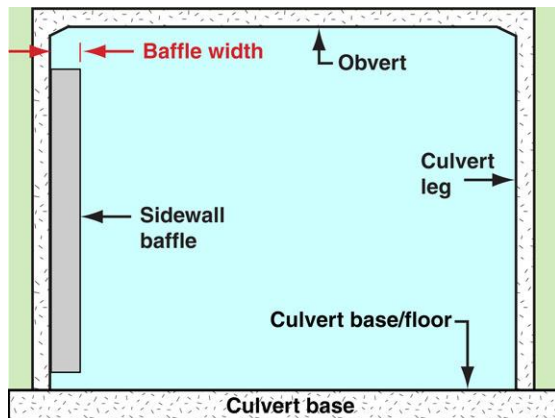
Appendix F: Baffle Engineering and Hydraulics

Introduction

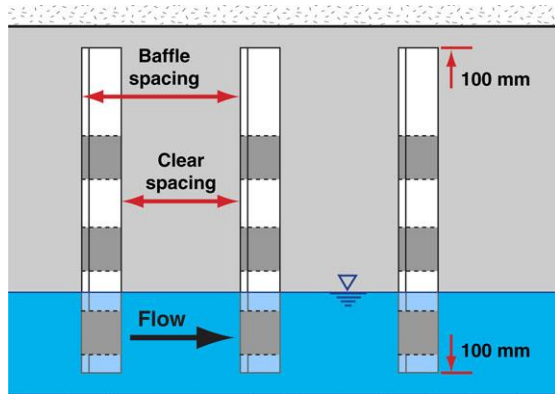


Photo supplied by Catchments & Creeks Pty Ltd

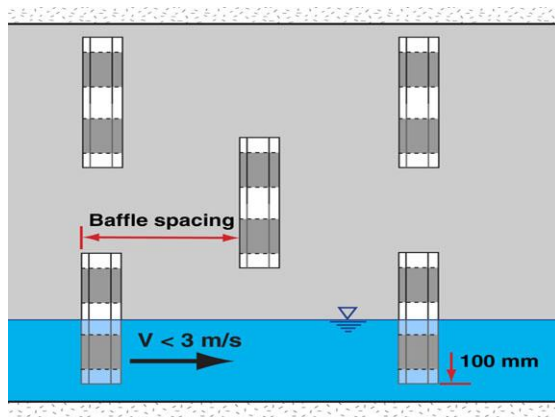
Sidewall baffles (NSW)



Baffle depth



Baffle spacing



Vertical spacing

Introduction

- Appendix F discusses the technical analysis that was used by the author to support the recommendations presented in Part 1 of this document, including:
 - baffle width
 - horizontal spacing of baffles
 - vertical positioning of baffles
 - controlling turbulence
 - hydraulic analysis of baffled walls
 - possible construction steps.

Baffle depth

- Issues that can affect the required **baffle width** (protrusion into the culvert) include:
 - maximum width of the target fish species
 - length of the target fish species
 - desired spacing of baffles
 - width of the culvert cell.

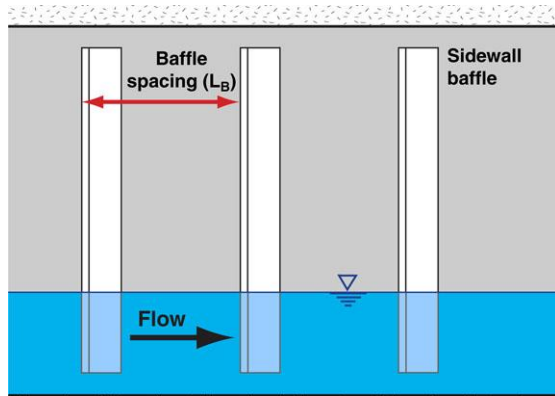
Baffle spacing

- Issues that can affect the sizing of the **baffle spacing** include:
 - average flow velocity within the cell
 - width of the target fish species
 - length of the target fish species (which affects the burst speed)
 - desirable level of turbulence
 - the spacing of baffles if attachment points are limited
 - location relative to the entry and exit (headwalls) of the culvert.

Baffle's vertical position on the sidewall

- Issues that can affect the sizing of the **baffle's vertical position** relative to the culvert floor include:
 - desirable height of each baffle
 - expected degree of settled bed load sediment
 - location relative to the entry and exit (headwalls) of the culvert.

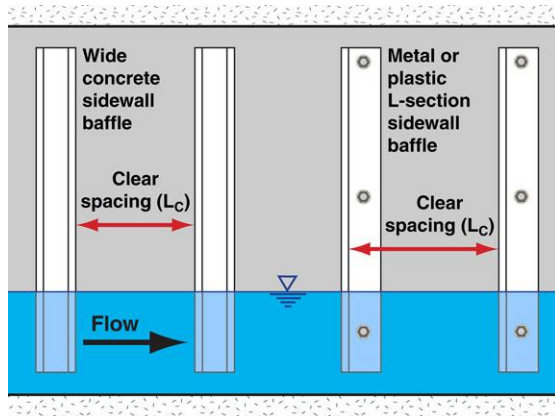
Adopted symbols



Baffle spacing

Baffle spacing (L_B)

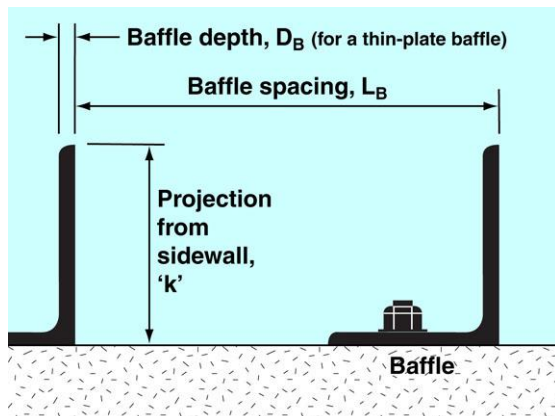
- The **baffle spacing** (L_B) is defined as the distance between the leading edges of two consecutive baffles.



Clear spacing of baffles

Clear spacing (L_C)

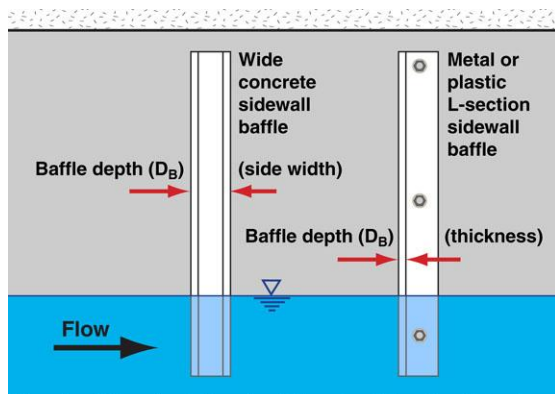
- The **clear spacing** (L_C) between adjacent baffles is defined as the baffle spacing (L_B) minus the baffle depth (D_B).



Projected width of a baffle

Projected baffle width (k)

- The **baffle width** (k) is the distance a baffle projects from the culvert floor or sidewall.
- Some documents may refer to this as the 'height' of a baffle if the baffle is mounted on the floor of a culvert.
- The symbol 'k' was chosen because it aligns with the hydraulic roughness parameter.

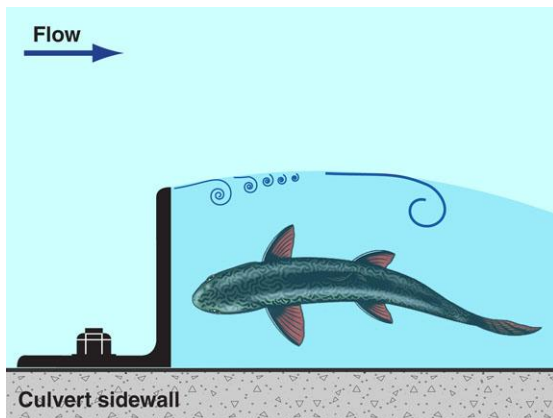


Baffle depth

Baffle depth (D_B)

- The **baffle depth** (D_B) is the thickness of the 'projected' portion of the baffle as measured in the direction of water flow.
- For thin-plate L-section baffles, its depth is the thickness of the 'web' (as shown above, left).
- For thin-plate channel section (C-section) baffles, the depth (side width) is taken as the depth of the 'channel' when placed flat on its back.

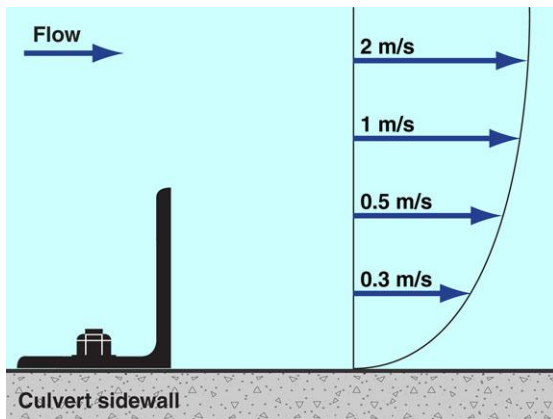
F1 - Baffle Width



Resting zone

Provision of resting zones

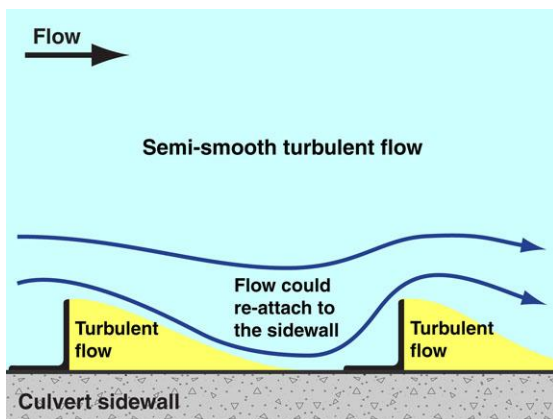
- The simplistic (non-scientific) rule is for the baffle width to be equivalent to, or greater than, the thickness of the target fish.
- The author (not being a biologist) has adopted the following:
 - 50 mm baffle width (small fish)
 - 100 mm baffle width (medium fish)
 - 200 mm baffle width (large fish)
- The 'size' being relative to fish species likely to move through a culvert.



Velocity profile

Provision of a desirable boundary layer

- The protective benefits of sidewall baffles varies with the average flow velocity within the culvert cell.
- As the average velocity increases, the shadow length behind the baffle increases, but the swimming difficulty increases:
 - $V < 4$ m/s, then minimum baffle width of 100 mm
 - $V > 4$ m/s, then minimum baffle width of 200 mm (an unlikely velocity in a fish-friendly culvert).



Boundary layer development

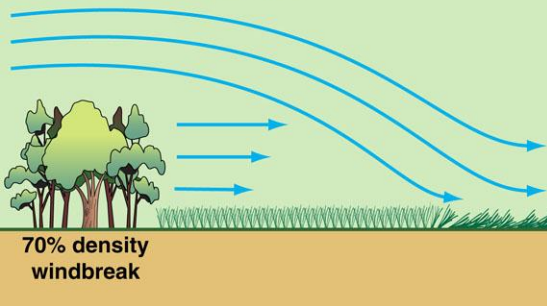
Effects of baffle spacing

- The effective protection that baffles can provide is expected to vary with the flow velocity in the culvert.
- When flow velocities are low, say < 1 m/s, the length of the shadow region downstream of a baffle reduces in size (i.e. the rate of flow expansion increases); however, due to this low velocity, it is easier for fish to swim past a baffle.

Note: The 'baffle width' is a measure of the baffle's lateral protrusion from the sidewall.

F2 - Baffle Spacing

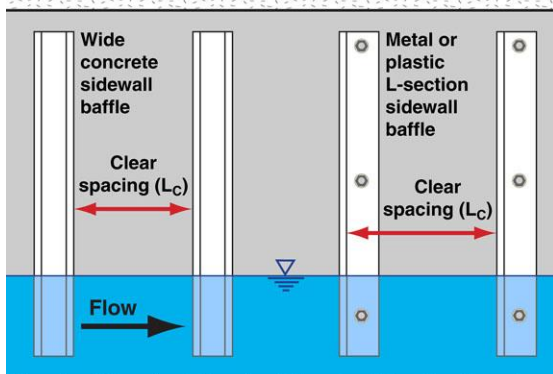
Wind deflected over the windbreak with minimal change in wind speed, but lower velocity air passes through the windbreak, which prevents the occurrence of back flow



Windbreak



Channel-section baffles (NSW)



Baffle clear spacing

Fluid mechanics

- **Fluid mechanics** is the study of fluids in motion.
- Both 'air' and 'water' behave as fluids.
- This means air flow can be studied using water, and water flow can be studied using air.
- Therefore, a study of windbreaks can provide some information about the expected water flow around sidewall baffles.

The differences

- With **windbreaks**, the critical factor is the air velocity adjacent to the soil surface; however with **baffles**, our interested is in the average velocity of the shadow area behind the baffle, not the velocity adjacent to the sidewall.
- Consequently, windbreak data will overstate the potential fish passage benefits of a sidewall baffle.
- Both systems should have similar levels of **turbulence**.

Recommended clear spacing of baffles

- The clear spacing (L_c) of sidewall baffles:
 - Six (6) times the baffle width for baffle widths less than 100 mm
 - Five (5) times the baffle width for baffle widths less than 200 mm
 - Five (5) times the baffle width for baffle widths greater than, or equal to 200 mm, and flow velocity less than 2 m/s.
 - Four (4) times the baffle width for baffle widths greater than, or equal to 200.
- The actual baffle spacing (L_B) is the **clear spacing** (L_c) plus the baffle's **depth** (D_B).

Explanation of the following tables



Warning

WARNING

- The information presented in tables F1 and F2 should NOT be used to set the spacing of sidewall baffles.
- Tables F1 and F2 have been presented solely for the purpose of transparency.
- The tables present the results of the hydraulic analysis performed by the author, which was just the first step in the analysis carried out by the author when determining the recommended baffle spacing.



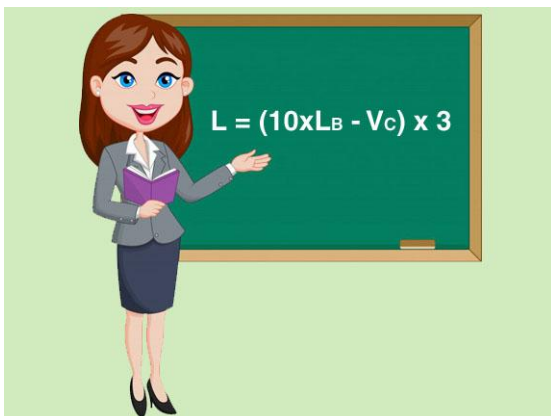
Explanation

The adopted hydraulic analysis

- The body length of each species was taken as the typical **body length** (BL), which is assumed to be 0.67 times the reported maximum body length.
- The 0.67 ratio of typical body length to maximum body length was determined from an average of 70 species.
- The burst speed of fish was assumed to be 10 BLPS (body lengths per second).
- The adopted duration of burst speed was taken as 3 seconds.
- The distance travelled over 3 seconds at burst speed was calculated as:

$$L = (10 \times BL - V) \times 3$$

- where:
 - L = travel distance [m]
 - BL = fish body length [m]
 - V = average velocity in culvert cell [m/s]
- The **travel distance** (L) divided by **baffle depth** (k) is the tabulated value (L/k).
- A '**non-result**' occurs when the burst speed of the fish is less than the average velocity in the culvert cell.



Adopted equation

Recommended baffle spacing

- The recommended baffle spacing is presented at the beginning of [Appendix E](#) and at the beginning of this appendix.
- Tables F3 and F4 also provide the recommended baffle spacing.
- The fish species data provided in tables F1 to F4 **should not** be trusted—this information is presented only for transparency.
- If you have species data that differs from these values, then you can adopt adjusted values as you see fit.



Questionable fish species data

Table F1 – Theoretical travel distance (baffle spacing/baffle width = L/k) NOT FOR USE

Species	Typical length (mm)	Baffle width (mm)	Theoretical maximum of (travel distance/baffle width)				
			Average flow velocity within the culvert cell (m/s)				
	1 m/s	2 m/s	3 m/s	4 m/s	5 m/s		
Empire Gudgeon (<i>Hypseleotris compressa</i>)	65	50					
Crimson-spotted Rainbowfish (<i>Melanotaenia duboulayi</i>)	70	50					
Flathead Gudgeon (<i>Philypnodon grandiceps</i>)	70	50		In this greyed region, the fish species is more likely to utilise boundary layer conditions on the bed (i.e. bed roughness), or swimming through gaps provided between the sidewall baffles and the sidewall.			
Murray-Darling Rainbowfish (<i>Melanotaenia fluviatilis</i>)	70	50					
Flat-headed Galaxias (<i>Galaxias rostratus</i>)	80	50					
Mountain Galaxias (<i>Galaxias olidus</i>)	80	50					
Purple-spotted Gudgeon (<i>Mogurnda adspersa</i>)	90	50					
Tailed Sole (<i>Aseraggodes klunzingeri</i>)	90	50					
Common Archerfish, Riflefish (<i>Toxotes chatareus</i>)	100	50					
Common Galaxias (<i>Galaxias maculatus</i>)	100	50					
Flathead Goby (<i>Glossogobius giuris</i>)	100	50					
Mouth Almighty (<i>Glossamia aprion</i>)	110	100	3			Utilise staggered short-length sidewall baffles, or sidewall roughness units (spoiler baffles), instead of full-height baffles. This allows fish to swim totally within the shadow of an upstream baffle.	
Primitive Archerfish (<i>Toxotes lorentzi</i>)	110	100	3				
Striped Gudgeon (<i>Gobiomorphus australis</i>)	110	100	3				
Southern Purple-spotted Gudgeon (<i>Mogurnda adspersa</i>)	120	100	6				
Spotted Galaxias (<i>Galaxias truttaceus</i>)	130	100	9				
Bullrout (<i>Notesthes robusta</i>)	150	100	15				
Bony Bream (<i>Nematalosa erebi</i>)	200	100	30				
Sea Mullet (<i>Mugil cephalus</i>)	200	100	30				
Spangled Perch (<i>Leiopotherapon unicolor</i>)	200	100	30				
Black Catfish, Eel-tailed Catfish (<i>Neosilurus ater</i>)	300	200	30	15			
Sleepy Cod (<i>Oxyeotris lineolata</i>)	300	200	30	15			
Fork-tailed Catfish, Salmon Catfish (<i>Arius leptaspis</i>)	350	200	38	23	8		
Freshwater Lontom (<i>Strongylura krefftii</i>)	350	200	38	23	8		

Table F2 – Theoretical travel distance (baffle spacing/baffle width = L/k) NOT FOR USE

Species	Typical length (mm)	Baffle width (mm)	Theoretical maximum of (travel distance/baffle width)				
			Average flow velocity within the culvert cell (m/s)				
	1 m/s	2 m/s	3 m/s	4 m/s	5 m/s		
Macquarie Perch (<i>Macquaria australasica</i>)	350	200	38	23	8	Utilise staggered short-length sidewall baffles, or sidewall roughness units (spoiler baffles), instead of full-height baffles. This allows fish to swim totally within the shadow of an upstream baffle.	
Silver Perch (<i>Bidyanus bidyanus</i>)	350	200	38	23	8		
Tarpon, Ox-eye Herring (<i>Megalops cyprinoides</i>)	350	200	38	23	8		
Toothless Catfish (<i>Anodontiglanis dahli</i>)	350	200	38	23	8		
Blue Catfish (<i>Arius graeffei</i>)	400	200	45	30	15		
Diamond Mullet, Ord River Mullet (<i>Liza alata</i>)	400	200	45	30	15		
Eel-tailed Catfish (<i>Tandanus tandanus</i>)	400	200	45	30	15		
Golden Perch (<i>Macquaria ambigua</i>)	400	200	45	30	15		
River Blackfish (<i>Gadopsis marmoratus</i>)	400	200	45	30	15		
Short-headed Lamprey (<i>Mordacia mordax</i>)	400	200	45	30	15		

An array of native fish species (not all regions) by Gunther Schmida



Delicate Blue-eye



Crimson-spotted Rainbowfish



Empire Gudgeon



Common Archerfish



Purple-spotted Gudgeon



Bony Bream



Black Catfish



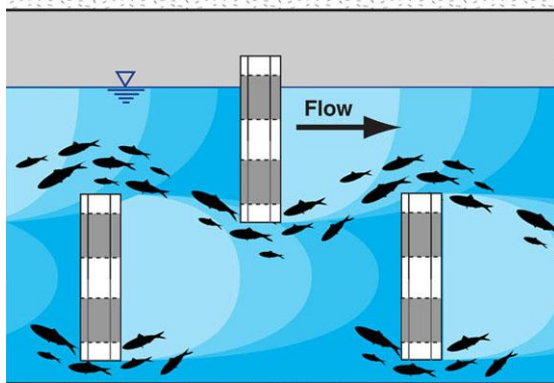
Freshwater Lontom

Table F3 – Recommended baffle spacing given as ‘baffle spacing/baffle width’ (L/k)

Species	Typical length (mm)	Baffle width (mm)	Theoretical maximum of (baffle spacing/baffle width, L/k)				
			Average flow velocity within the culvert cell (m/s)				
	1 m/s	2 m/s	3 m/s	4 m/s	5 m/s		
Empire Gudgeon (<i>Hypseleotris compressa</i>)	65	50					
Crimson-spotted Rainbowfish (<i>Melanotaenia duboulayi</i>)	70	50					
Flathead Gudgeon (<i>Philypnodon grandiceps</i>)	70	50		In this greyed region, the fish species is more likely to utilise boundary layer conditions on the bed (i.e. bed roughness), or swimming through gaps provided between the sidewall baffles and the sidewall.			
Murray-Darling Rainbowfish (<i>Melanotaenia fluviatilis</i>)	70	50					
Flat-headed Galaxias (<i>Galaxias rostratus</i>)	80	50					
Mountain Galaxias (<i>Galaxias olidus</i>)	80	50					
Purple-spotted Gudgeon (<i>Mogurnda adspersa</i>)	90	50					
Tailed Sole (<i>Aseraggodes klunzingeri</i>)	90	50					
Common Archerfish, Riflefish (<i>Toxotes chatareus</i>)	100	50					
Common Galaxias (<i>Galaxias maculatus</i>)	100	50					
Flathead Goby (<i>Glossogobius giuris</i>)	100	50					
Mouth Almighty (<i>Glossamia aprion</i>)	110	100	5			Utilise staggered short-length sidewall baffles, or sidewall roughness units (spoiler baffles), instead of full-height baffles. This allows fish to swim totally within the shadow of an upstream baffle.	
Primitive Archerfish (<i>Toxotes lorentzi</i>)	110	100	5				
Striped Gudgeon (<i>Gobiomorphus australis</i>)	110	100	5				
Southern Purple-spotted Gudgeon (<i>Mogurnda adspersa</i>)	120	100	5				
Spotted Galaxias (<i>Galaxias truttaceus</i>)	130	100	5				
Bullrout (<i>Notesthes robusta</i>)	150	100	5				
Bony Bream (<i>Nematalosa erebi</i>)	200	100	5				
Sea Mullet (<i>Mugil cephalus</i>)	200	100	5				
Spangled Perch (<i>Leiopotherapon unicolor</i>)	200	100	5				
Black Catfish, Eel-tailed Catfish (<i>Neosilurus ater</i>)	300	200	5	4			
Sleepy Cod (<i>Oxyeotris lineolata</i>)	300	200	5	4			
Fork-tailed Catfish, Salmon Catfish (<i>Arius leptaspis</i>)	350	200	5	4	4		
Freshwater Lontom (<i>Strongylura krefftii</i>)	350	200	5	4	4		

Table F4 – Recommended baffle spacing given as ‘baffle spacing/baffle width’ (L/k)

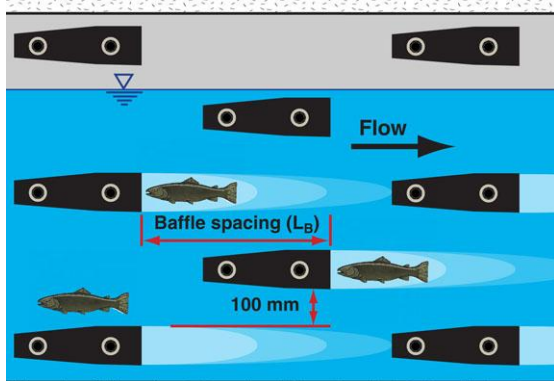
Species	Typical length (mm)	Baffle width (mm)	Theoretical maximum of (baffle spacing/baffle width, L/k)				
			Average flow velocity within the culvert cell (m/s)				
			1 m/s	2 m/s	3 m/s	4 m/s	5 m/s
Macquarie Perch (<i>Macquaria australasica</i>)	350	200	5	4	4	Utilise staggered short-length sidewall baffles, or sidewall roughness units (spoiler baffles), instead of full-height baffles. This allows fish to swim totally within the shadow of an upstream baffle.	
Silver Perch (<i>Bidyanus bidyanus</i>)	350	200	5	4	4		
Tarpon, Ox-eye Herring (<i>Megalops cyprinoides</i>)	350	200	5	4	4		
Toothless Catfish (<i>Anodontiglanis dahli</i>)	350	200	5	4	4		
Blue Catfish (<i>Arius graeffei</i>)	400	200	5	4	4		
Diamond Mullet, Ord River Mullet (<i>Liza alata</i>)	400	200	5	4	4		
Eel-tailed Catfish (<i>Tandanus tandanus</i>)	400	200	5	4	4		
Golden Perch (<i>Macquaria ambigua</i>)	400	200	5	4	4		
River Blackfish (<i>Gadopsis marmoratus</i>)	400	200	5	4	4		
Short-headed Lamprey (<i>Mordacia mordax</i>)	400	200	5	4	4		



Short-length section baffles

Short-length sidewall baffles

- Short-length baffles do not extend the full height of the culvert, but are spaced apart, and work as a collection of roughness units.



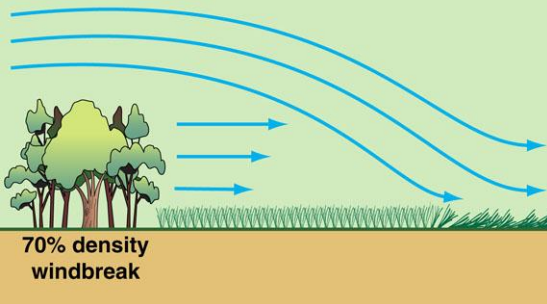
Sidewall roughness units

Sidewall roughness units (spoiler baffles)

- The intent of this system is to:
 - provide a more uniform boundary layer condition over the sidewall
 - allow fish to always swim within the boundary layer, instead of having to burst out into the high-velocity flow in order to pass around a full height baffle
 - reduce the risk of debris blockages occurring within the culvert cell.
- Recommended if velocity > 3.5 m/s.

Key outcomes from a study of **windbreak** fluid mechanics

Wind deflected over the windbreak with minimal change in wind speed, but lower velocity air passes through the windbreak, which prevents the occurrence of back flow

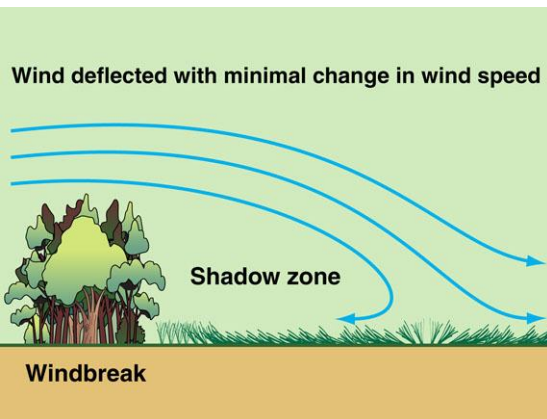


Porosity of a windbreak

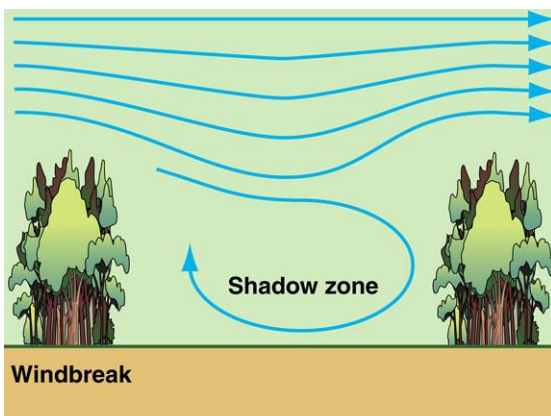


Photo supplied by Catchments & Creeks Pty Ltd

Increased porosity!



Windbreak shadow zone



Windbreak (Qld)

Porosity of a windbreak

- The effectiveness of a windbreak is affected by the porosity of the windbreak.
- Partial air flow through a windbreak prevents a rapid change in air pressure, which reduces the degree of turbulence, and increases the effective length of protection (the 'shadow' zone).
- Optimum protection is achieved with approximately 70% tree porosity, which means that porous baffles may perform better than solid baffles.

Relatable benefit to fish passage

- The adverse outcome for a solid windbreak is a logical outcome given our understanding of fluid mechanics.
- This outcome is directly relatable to the design of fish passage baffles.
- Fish passage would likely benefit from baffles having approximately 70% porosity; however, designers should not automatically request holes to be drilled into all metal baffles.
- The milk crate design utilises this benefit.

Effective shadow zone

- It has been found that windbreaks **protect the soil** over a distance of 15 to 20 times the height of the windbreak.
- Windbreaks also reduce wind velocities some 2 to 5 times the height of the windbreak **upwind** of the actual windbreak.
- Thus, regularly spaced windbreaks (i.e. similar to regularly spaced baffles) provide a wider shadow zone compared to a single windbreak.

Summary

- Summary of windbreak analysis:
 - the relative increase in air speed with distance from the windbreak
 - benefits of regularly spaced windbreaks
 - effective protection distance of 15 to 20 times the height of the windbreak
 - potential benefits of allowing some flow to pass through a windbreak, with the optimum being 70% porosity.

Windbreak testing

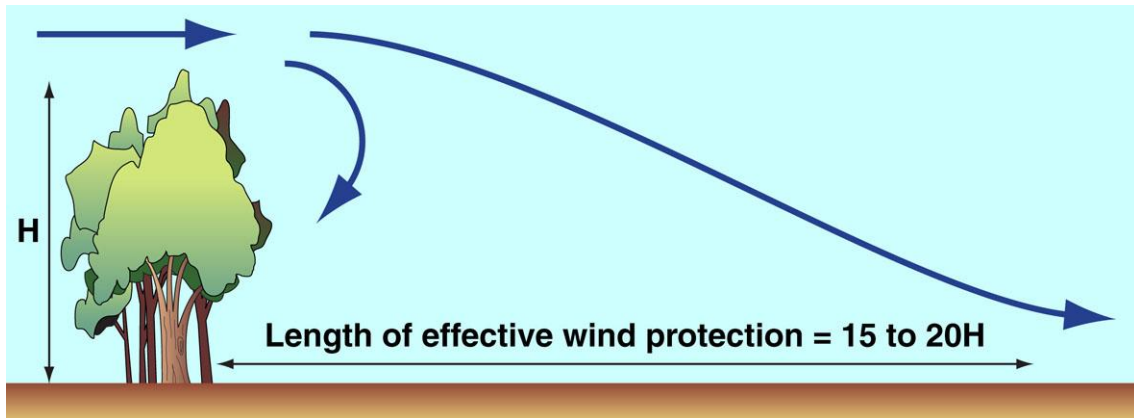


Figure F1 – Region of protection of soil from wind erosion downwind of a windbreak

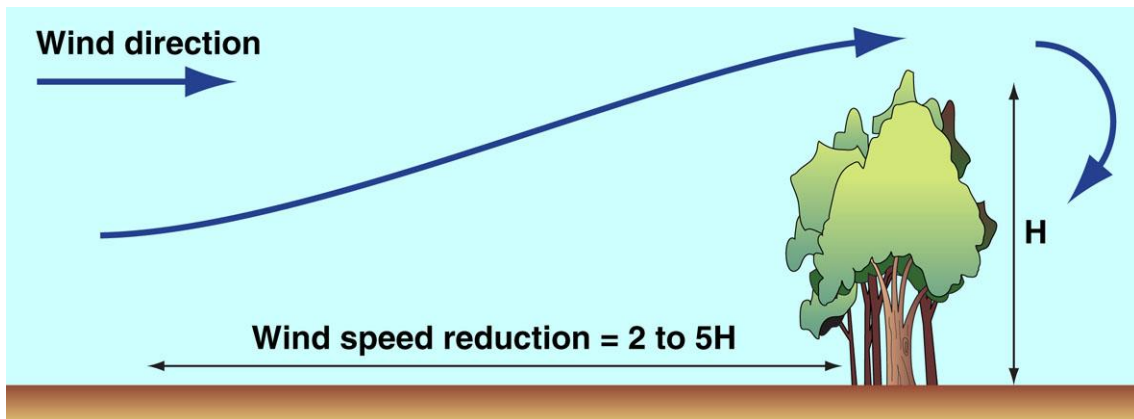


Figure F2 – Region of protection of soil from wind erosion upwind of a windbreak

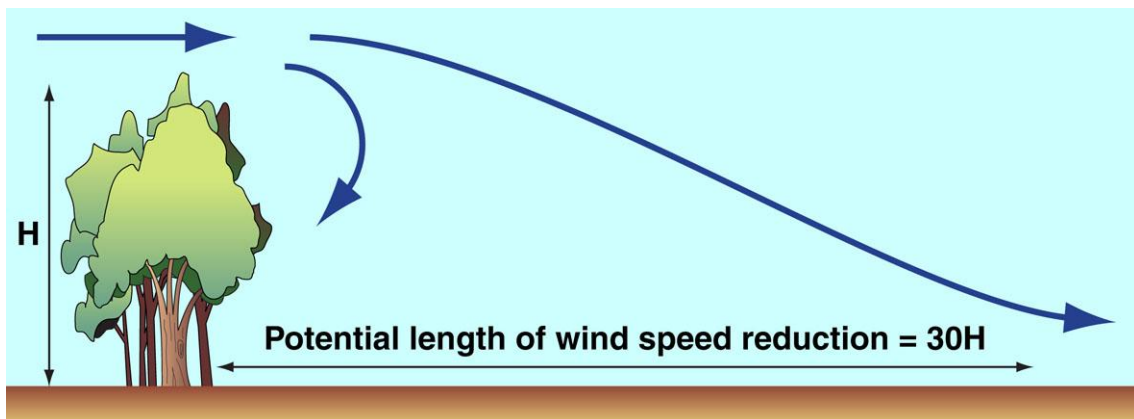


Figure F3 – Expected region of protection with 70% tree porosity

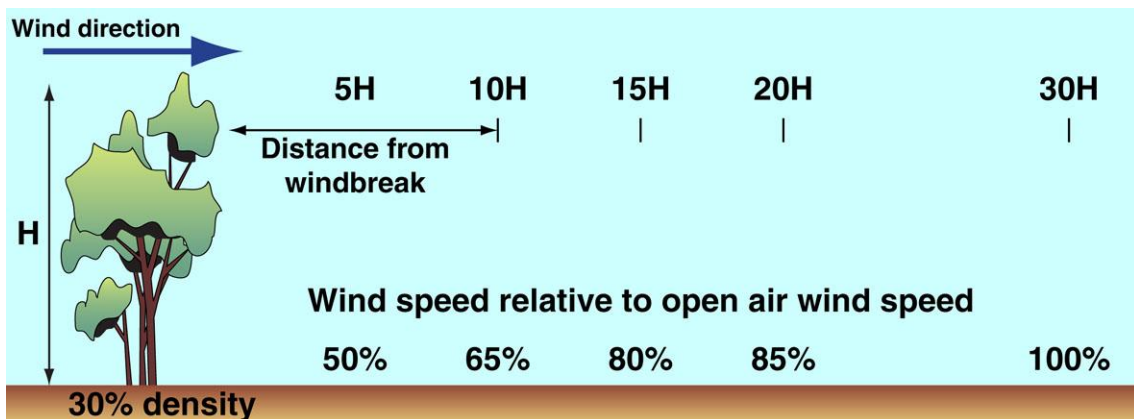


Figure F4 – Reduction in wind speed for a 30% tree porosity windbreak

Windbreak testing

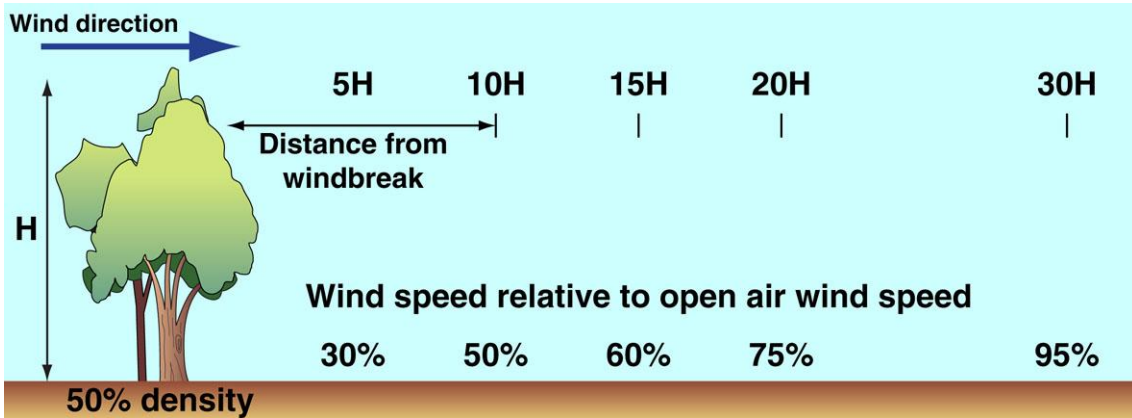


Figure F5 – Reduction in wind speed for a 50% tree porosity windbreak

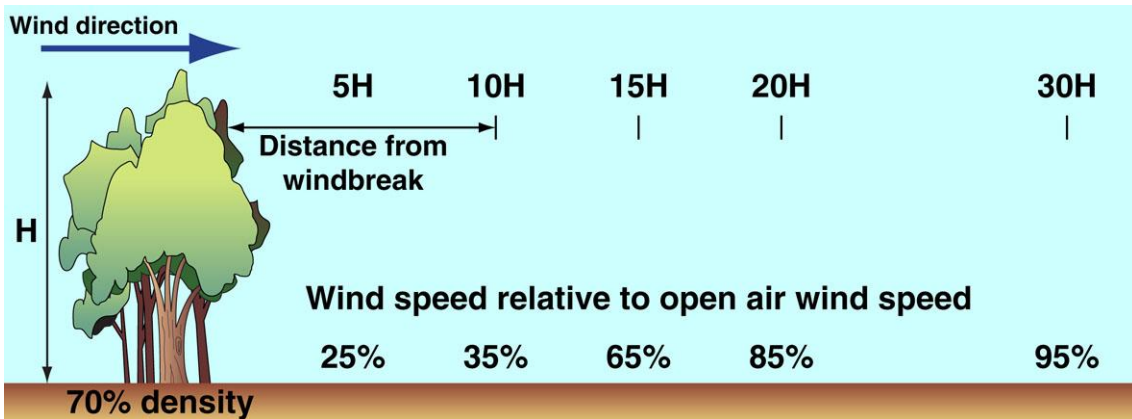


Figure F6 – Reduction in wind speed for a 70% tree porosity windbreak

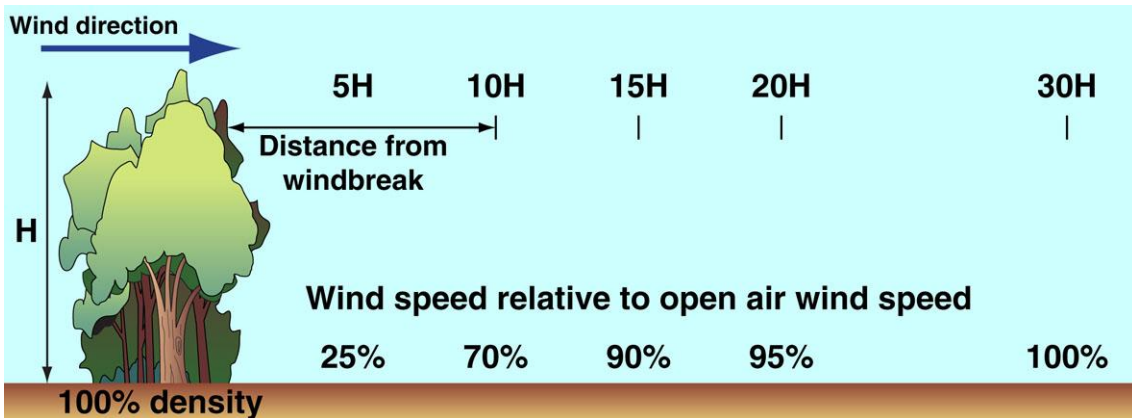


Figure F7 – Reduction in wind speed for a solid (100%) windbreak

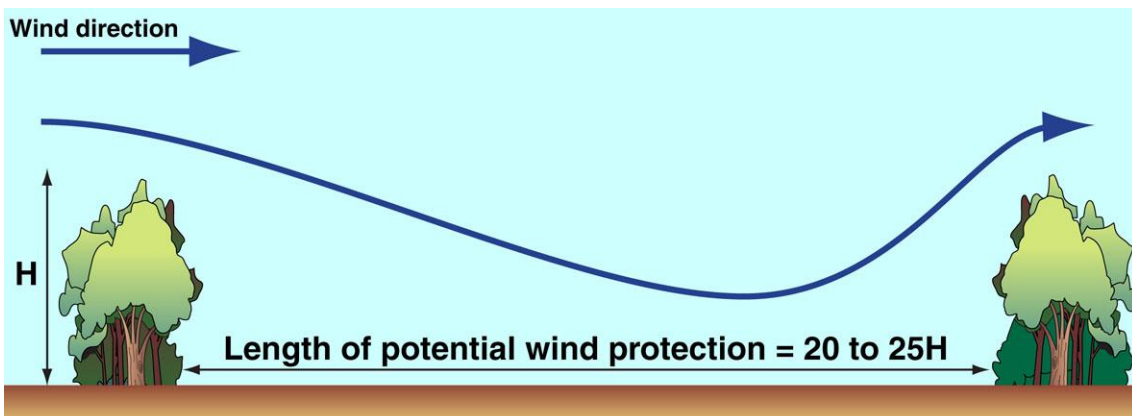


Figure F8 – Potential wind protection within a series of windbreaks

Application of the windbreak data to the design of culvert baffles

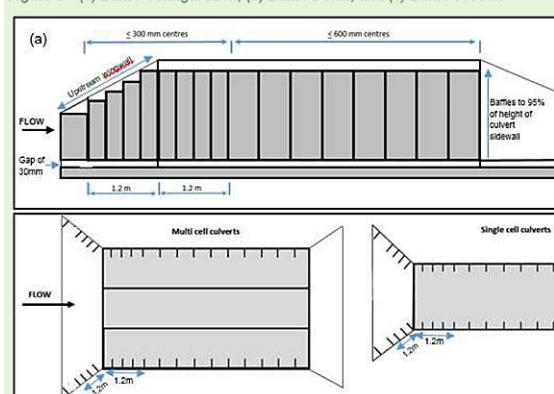


Caution

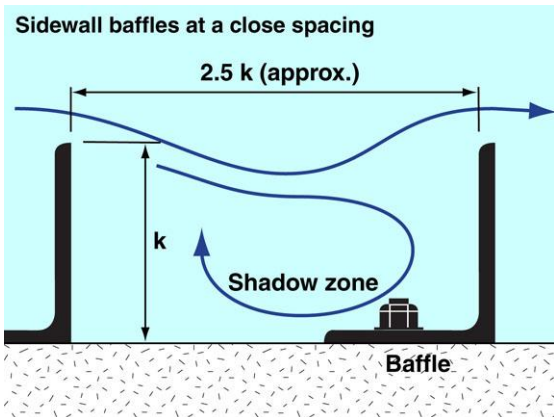
Caution

- The windbreak results are Reynold's number dependent, which means they are affected by the viscosity of the fluid.
- This means the windbreak results can only be considered 'indicative', not conclusive.
- The most credible information we gain from the windbreak test is the general flow pattern that is expected downstream of a sidewall baffle.

Figure 3 – (a) Baffle Configuration; (b) Baffle Detail; and (c) Baffle section



2018 Queensland DAF guideline



Baffles set too close



Wingwall baffles (Qld)

Assessment of existing baffle spacing recommendations

- In high velocity culverts, fish would need to rest within dead water areas, and thus a baffle spacing of 5 times the baffle width or less ($L/k < 5$) would be required.
- These results appear to confirm that the currently (2025) recommended baffle spacing of four (4) times the baffle width is conservative.
- It is likely that the baffle spacing could be extended to six (6) times the baffle width for most flow velocities.

Caution the risk of closely-spaced baffles

- The windbreak study showed that if the baffle spacing is reduced to just 2.5 times the baffle's width, then a single circulating eddy could form between two baffles.
- This is a hydraulic problem that has been observed in many situations.
- When water is given a near-square space, and there is a passing flow, then induced flow currents can set-up a circulating whirlpool, which should be avoided in the design of sidewall baffles.

Baffle spacing on wingwalls and at the culvert entry/exit

- Current recommendations reduce the baffle spacing on wingwalls and at the entry and exit of a culvert; however, this could potentially set up some water circulation problems (as discussed above).
- In conclusion; the baffle spacing on wingwalls should not be reduced to less than three (3) times the baffle width.

Expected flow patterns around sidewall baffles

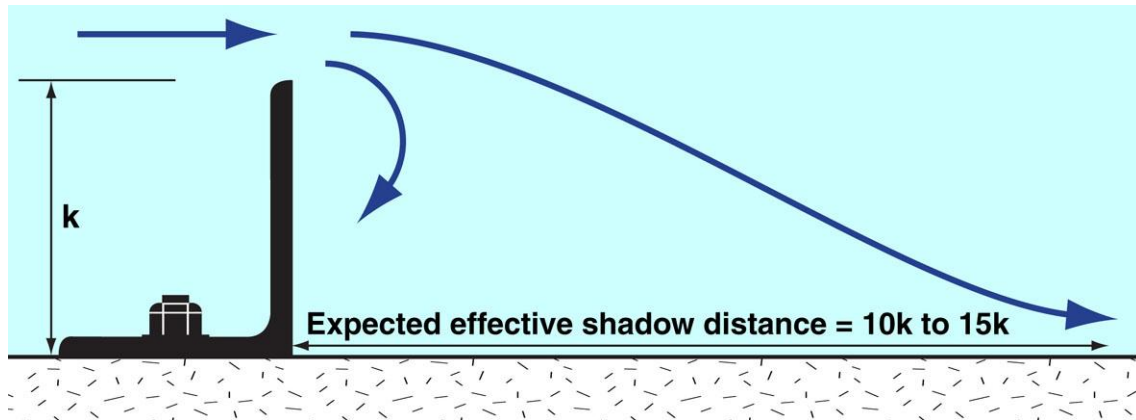


Figure F9 – Potential flow pattern for a sidewall baffle

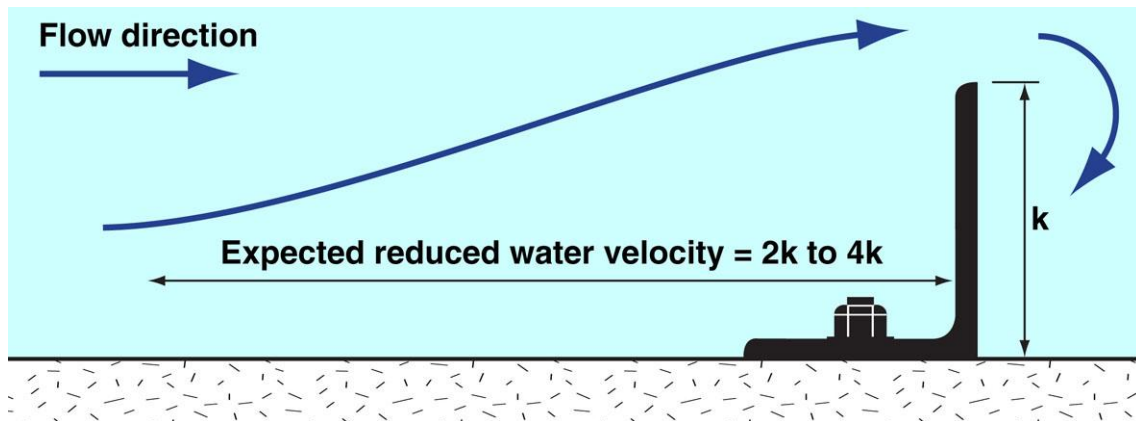


Figure F10 – Potential flow pattern upstream of a sidewall baffle

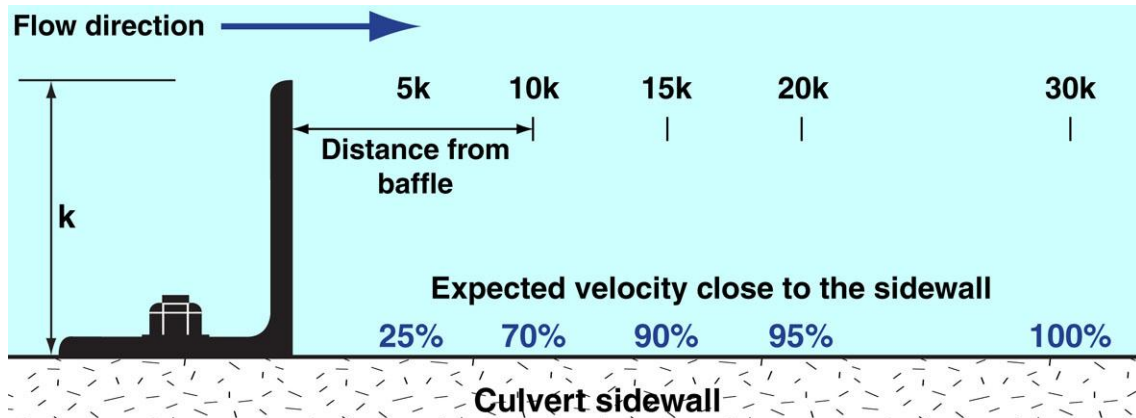


Figure F11 – Potential velocity reduction downstream of a sidewall baffle

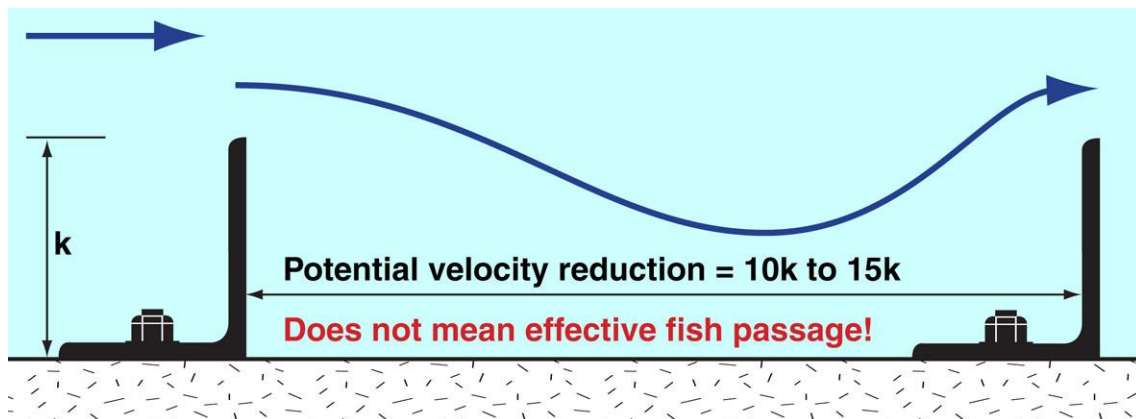
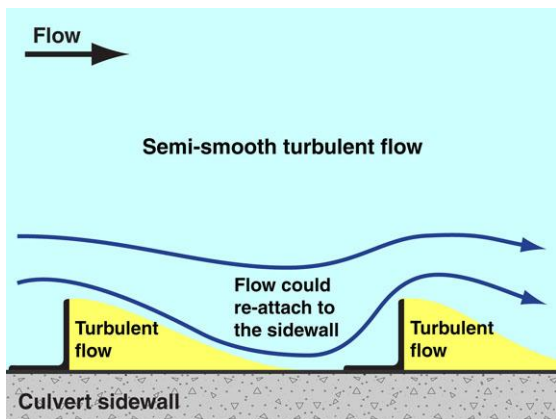
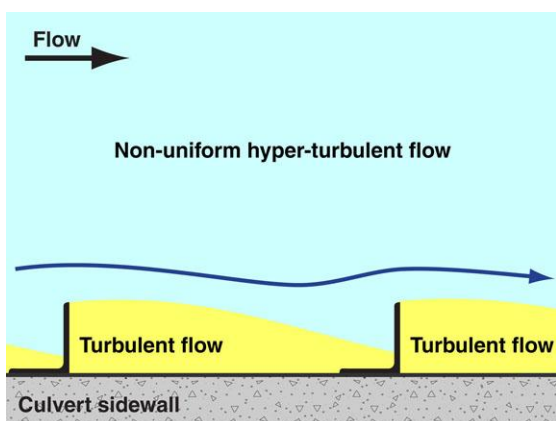


Figure F12 – Potential flow conditions between consecutive sidewall baffles

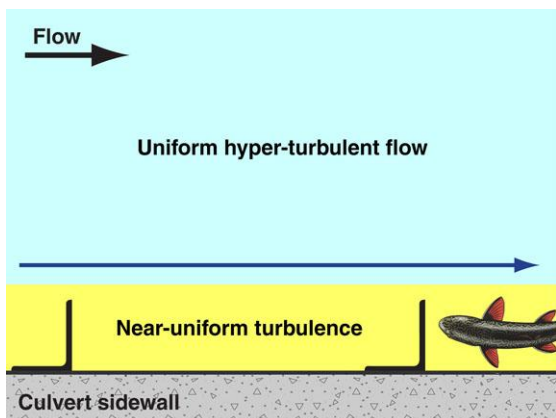
Expected effects of variations in flow velocity



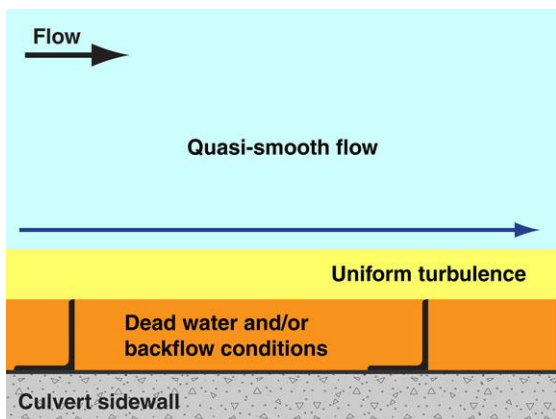
Semi-smooth flow for $L/k = 13.9$



Hyper-turbulent flow for $L/k = 10.4$



Uniform hyper-turbulent flow for $L/k = 6.95$



Quasi-smooth flow for $L/k = 3.47$

Flow conditions during periods of low velocity

- The effective protection that baffles can provide is expected to vary with the flow velocity in the culvert.
- When flow velocities are low, say < 1 m/s, the length of the shadow region downstream of a baffle reduces in size (i.e. the rate of flow expansion increases); however, due to this low velocity, it is easier for fish to swim past a baffle.

The effects of increasing flow velocity

- As the flow velocity increases, the length of the shadow region increases, but the degree of turbulence increases, and it becomes more difficult for fish to swim past a baffle.

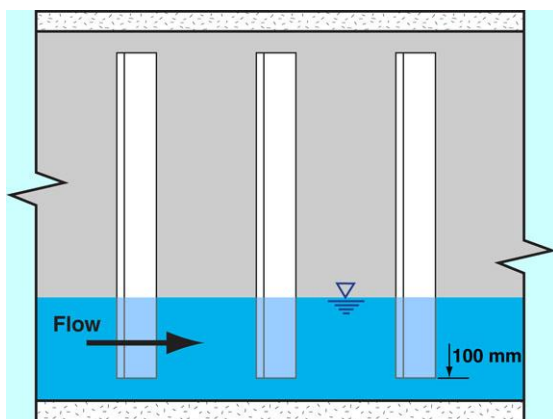
Flow conditions during high velocity

- During periods of high flow velocity, say greater than 4 m/s within a culvert, a full boundary layer can engulf the baffled sidewall.
- Fish can find great protection downstream of a baffle, but getting around the baffle (i.e. entering the high velocity flow) can be extremely difficult, except for fish with a body length exceeding 500 mm.

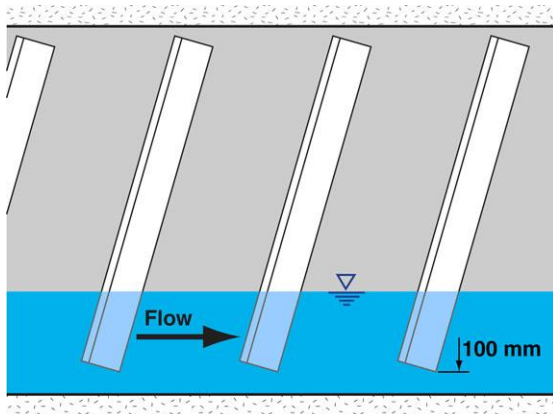
Extreme conditions

- At high flow velocities it is possible for the boundary layer to extend beyond the width of the baffles; however, flow velocities are still expected to be too high for most fish.

Additional information



Vertical, full-height baffles

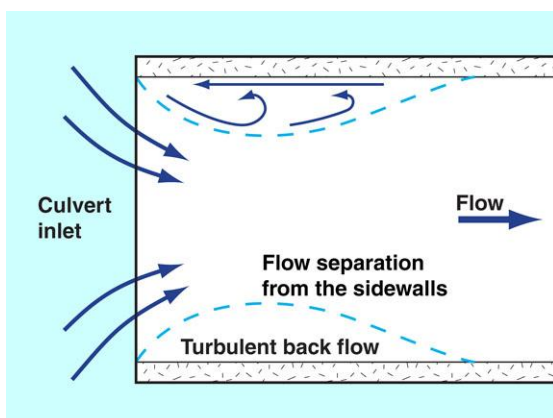


Inclined baffles



Photo supplied by Catchments & Creeks Pty Ltd

Flow separation at culvert inlet (Qld)



Hydraulic conditions at culvert inlet

Vertical baffles

- The use of vertical baffles allows better interaction between the baffles placed on the wingwalls and the internal-cell baffles.

Inclined baffles

- It is expected that inclined baffles will be less likely to trap and hold large woody debris, but this has not been proven.
- Field tests conducted by Queensland Main Roads concluded (verbal communication) that tilting the baffles did not decrease the effective fish passage compared to vertical baffles (a 'good' outcome).
- Of course, the use of staggered short-length baffles, or spoiler baffles, can also reduce the risk of debris blockage.

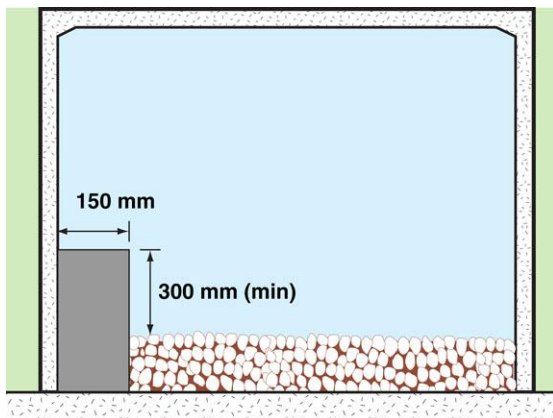
Potential changes in baffle spacing at culvert inlet and outlet

- The author questions the currently (2025) adopted spacing of the baffles at the upstream end of the culvert.
- The currently adopted baffle spacing is two (2) times the baffle width (k).
- The author recommends a baffle spacing of four (4) times the baffle width (k).

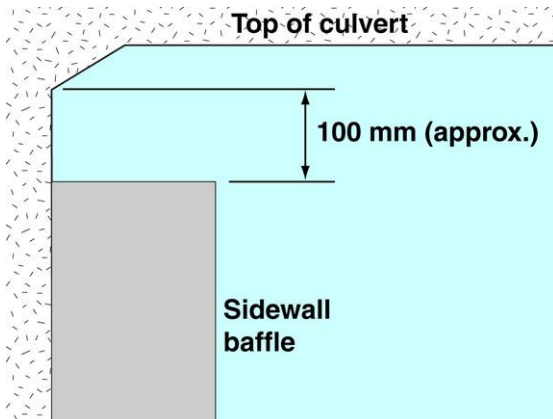
Flow conditions at culvert entry

- At the inlet of a typical culvert there is the strong possibility that flow separation will occur.
- This means there is likely to be flow reversal in this region.

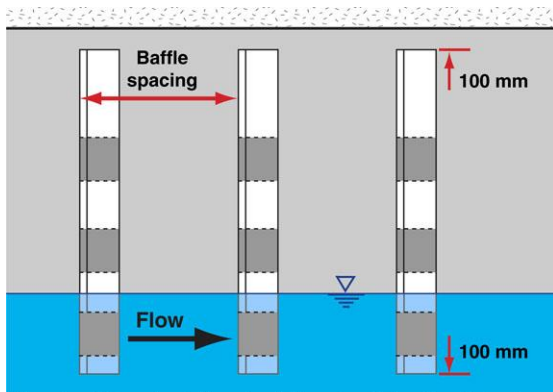
F3 - Vertical Position



Half-height baffle



Maximum height (side view)



Spacing from the culvert floor

Introduction

- Some authors recommend that sidewall baffles should extend to a height of just 500 mm because most fish passage occurs in flows less than 500 mm deep.
- This assumption supports the use of L-shaped corner baffles.
- The author questions this assumption, especially if the culvert is subjected to sedimentation problems.

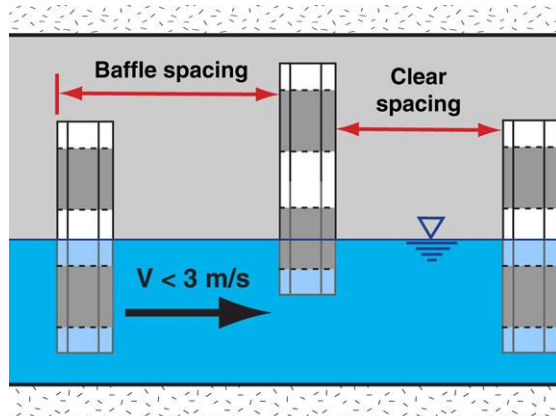
Proximity to the culvert roof

- Recommended maximum height of sidewall baffles is 100 mm below the culvert roof, or the corner chamfer, whichever the case may be.

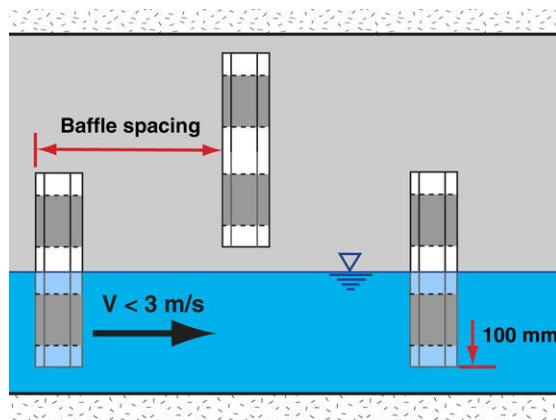
Spacing from the culvert floor

- Recommended maximum height of 100 mm above the culvert floor, or the expected permanent sediment elevation, whichever the case may be.

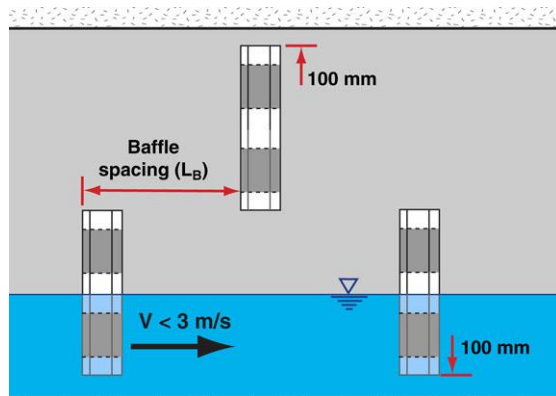
The vertical positioning of short-length baffles



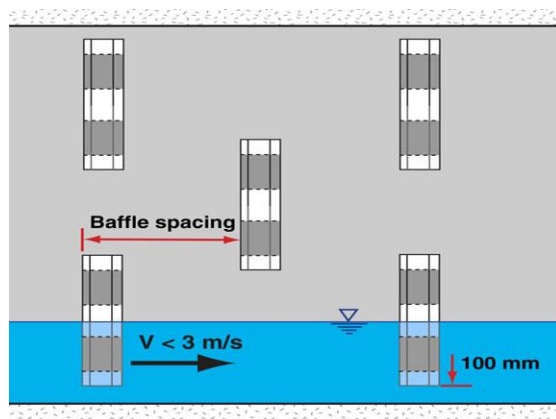
Low-height culvert



Slightly higher culvert



Even higher culvert



Tall culvert

Low-height culverts

- Baffles staged in height, one 100 mm above the culvert floor (or the expected permanent sediment elevation, whichever the case may be), and the next a 100 mm below the roof.

Note: For broad-width concrete baffles, the actual baffle spacing (L_B) is the clear spacing (L_C) plus the depth of the baffle (D_B).

The baffle's depth (side width) is its thickness in the direction of flow.

Slightly higher culverts

- For a slightly higher culvert, the baffles should be staged in height, one baffle located 100 mm above the culvert floor, and the next 100 mm below the roof.
- The amount of overlap between consecutive baffles will depend on the height of the culvert, and the length of the baffles.

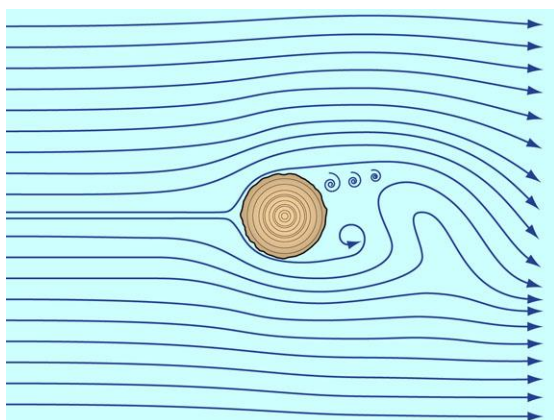
Even higher culverts

- As the culvert height increases, the upper row of baffles should be no more than 200 mm above the lower row of baffles, otherwise, a third row of baffles will be required.

Tall culverts

- The top row of baffles located 100 mm below the roof.
- The bottom row of baffles located 100 mm above the culvert floor, or the expected permanent sediment elevation, whichever the case may be.
- An upper row of baffles no higher than 200 mm above the immediate lower row of baffles.

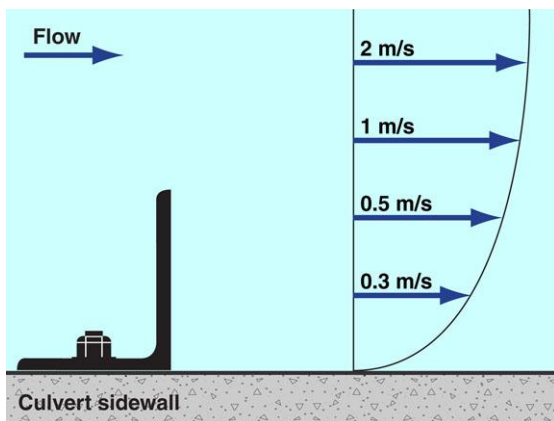
F4 - Turbulence



Turbulent flow

Introduction

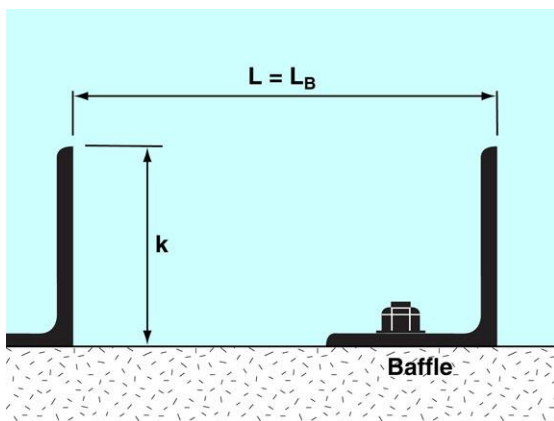
- With regards to fish passage, there are two critical hydraulic parameters:
 - the local flow velocity
 - the degree of turbulence within the flow.
- Turbulence is important for the following reasons:
 - the general comfort of the fish, and its desire to continue moving through a culvert
 - the potential for the fish to be pushed against the culvert or baffle.



Boundary layer thickness

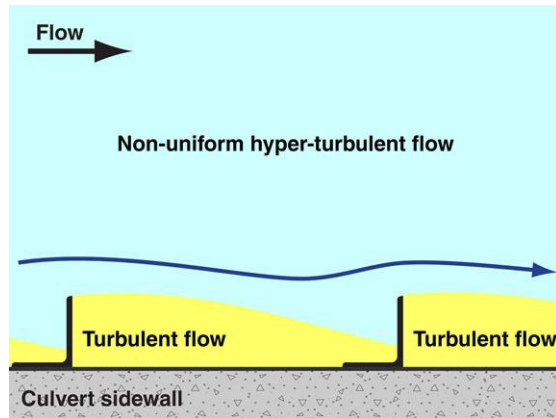
Fluid mechanics

- The science of fluid mechanics can tell us several things about baffles that are relevant to fish passage, including:
 - the thickness of the boundary layer adjacent to the outer edge of any roughness unit is likely to be similar in size to the thickness of the roughness units
 - this means the total width of the boundary layer (relative to the sidewall) is likely to be twice the thickness of the roughness units
 - the thickness of the boundary layer can be affected by the shape of the baffle; however, this effect is reduced because the flow profile around a single baffle interacts with the adjacent baffles
 - if the average flow velocity in the culvert is **low** (say, < 2 m/s), then the size of the turbulence can be large, but its severity is low
 - if the average flow velocity in the culvert is **high** (say, > 3 m/s), then the size of the turbulence can be small, but its severity is usually high.

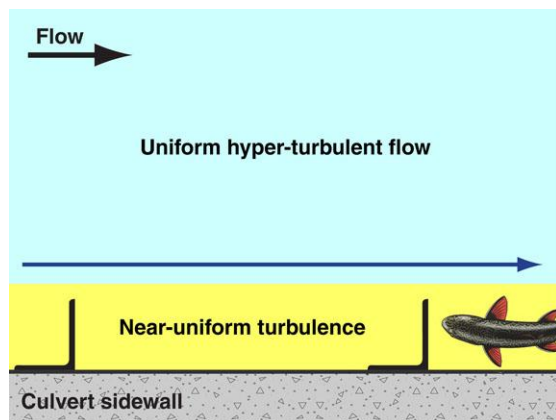


Terminology

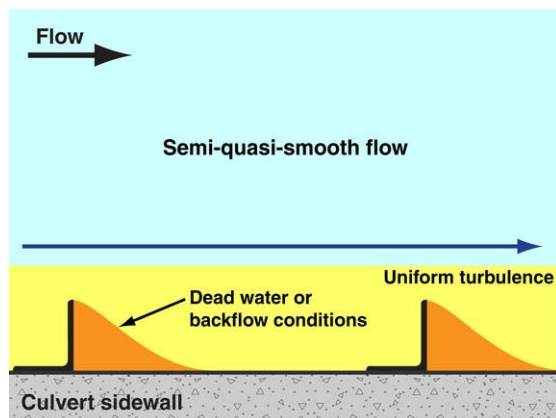
Flow conditions between consecutive baffles



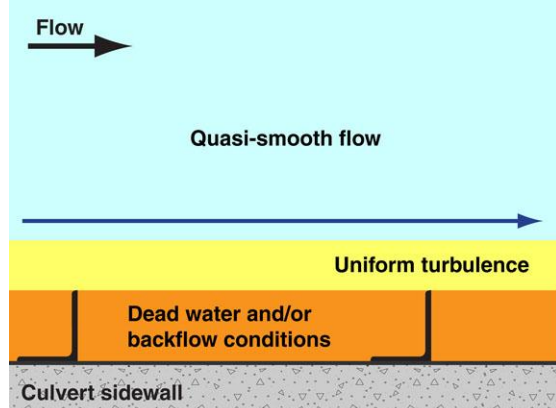
Hyper-turbulent flow for $L/k = 10.4$



Uniform hyper-turbulent flow for $L/k = 6.95$



Semi-quasi-smooth flow for $L/k = 5.21$



Quasi-smooth flow for $L/k = 3.47$

Introduction

- Numerous hydraulic studies have been performed on roughness units.
- In these examples, the 'yellow' areas represent 'shadow zones' downstream of the baffles where the turbulence can be large in size, but low in severity.

Legend:

- L = distance between baffles
- k = height (or really the projected depth/width) of the baffles.

Uniform hyper-turbulent flow

- For the [uniform hyper-turbulent flow](#) condition, the individual wakes intermingle resulting in a uniform layer of turbulence covering the baffles.
- Fish may be able to rest within the areas of turbulent flow formed downstream of baffles than are spaced 5 to 10 times the baffle depth ($5 < L/k < 10$).

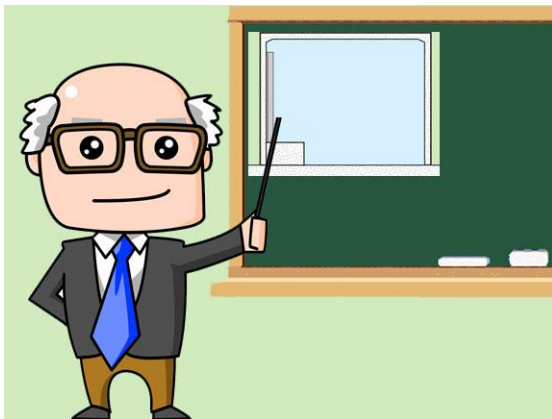
Semi-quasi-smooth flow

- In the [semi-quasi-smooth flow](#) condition a trapped vortex (shown in yellow) forms downstream of the baffle, but does not fully fill the space between the baffles.
- The [orange regions](#) represent 'dead water' zones, or regions where backflow is expected.
- Field test (Tim Marsden, 2015) observed fish pointing downstream in this zone, meaning they were pointing into the backflow.

Quasi-smooth flow

- We know that if a vortex forms downstream of a baffle, the vortex will prefer to rotate as a near perfect circle, which can influence the location where the vortex forms.
- A vortex is simply well-organised turbulence where the water rotates around a central axis.
- The windbreak study showed that if the baffle spacing is reduced to just 2.5 times the baffle depth, then a single circulating eddy can form between two baffles.

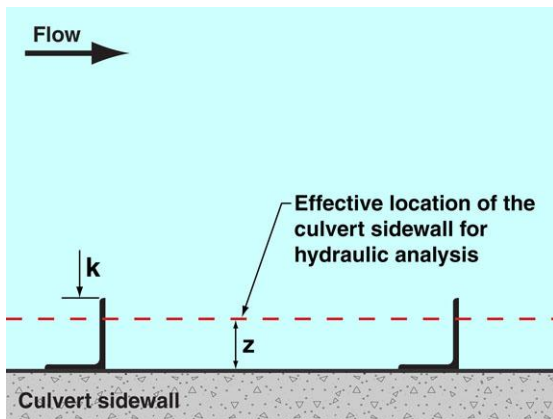
F5 - Hydraulic Analysis



Hydraulics professor

Introduction

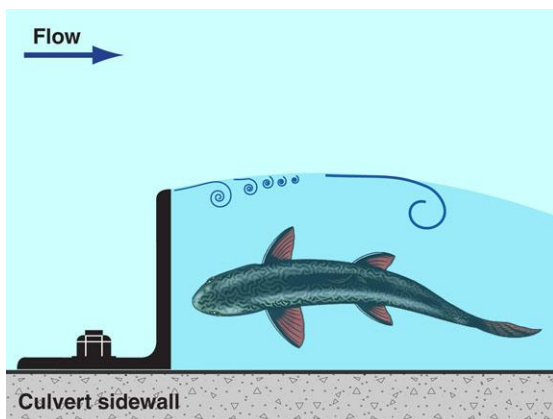
- The two hydraulic issues discussed in this appendix are:
 - the effective flow width changes caused by the introduction of sidewall baffles
 - the effective Manning's roughness of a baffled sidewall.



Effective width of dead water zone (z)

The effective flow width changes caused by the introduction of sidewall baffles

- Ideally, the hydraulic analysis of a baffled culvert cell must assume that any continuous dead water region formed between the baffles, is excluded from the effective flow area.
- This means that the effective width (W) must be reduced by the distance ' z ' determined from an appropriate formula.
- However, in a typical culvert analysis, this correction is usually not performed.

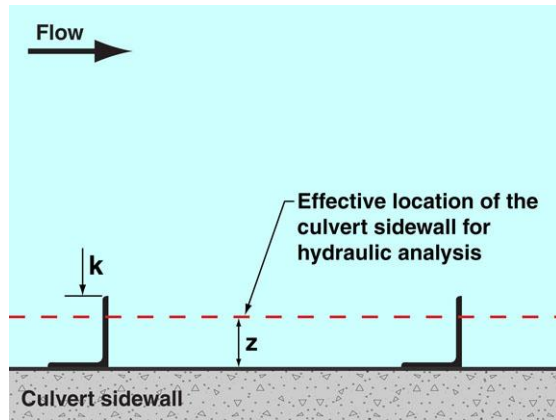


Fish resting area

The effective Manning's roughness of a baffled sidewall

- Even though the hydraulic roughness of a baffled wall would vary with the shape of the baffles, a simplified equation (F1) has been developed in order to estimate the effective Manning's roughness of the sidewall.
- In order to determine the overall Manning's roughness of the culvert cell, a 'complex' Manning's roughness needs to be determined, as discussed in Step 10 of Part 1 of this document.

Effective flow width of a baffled culvert cell



Effective width of dead water zone (z)

Hydraulics

- If the parameter 'z' is taken as the effective location of the culvert sidewall (as used in hydraulic analysis), and 'k' is the projected width of the baffles, and 'L' is the spacing of the baffles, then the parameter 'z' can be determined from Table F5.

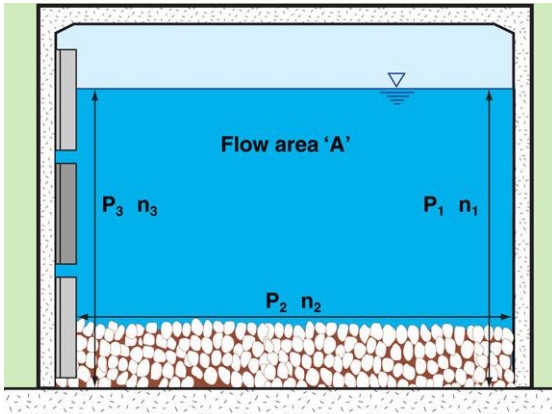
where:

- L = the clear spacing L_c
- k = the baffle's protrusion width
- z = reduction in effective flow width.

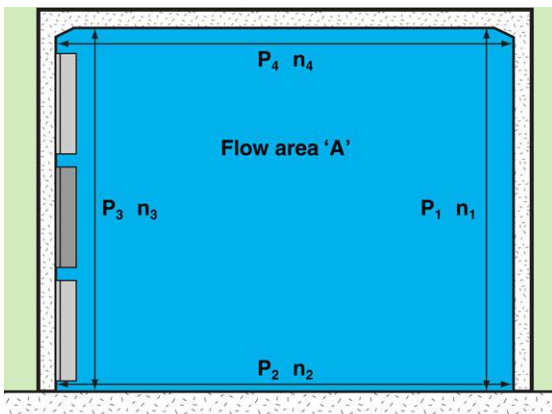
Table F5 – Values of parameter 'z'

L/k	10	6	5	4	< 4
z/k	0.40	0.62	0.77	1.0	1.0

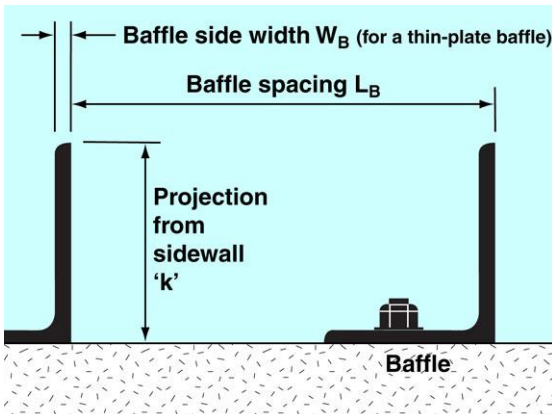
Effective Manning's roughness of a baffled sidewall



Partial-full flow conditions



Culvert flowing full



Terminology

Table F6 - Manning's roughness of a baffled sidewall with baffle spacing, LB=2			
R	Ratio of hydraulic radius of flow to baffle width (R/L)		
(m)	5	10	20
0.25	0.04	0.03	0.02
0.5	0.04	0.03	0.02
1.0	0.04	0.03	0.02
1.5	0.04	0.03	0.02
2.0	0.04	0.03	0.02
2.5	0.04	0.03	0.02
3.0	0.04	0.03	0.02
4.0	0.04	0.03	0.02
5.0	0.04	0.03	0.02

Table F7 - Manning's roughness of a baffled sidewall with baffle spacing, LB=4			
R	Ratio of hydraulic radius of flow to baffle width (R/L)		
(m)	5	10	20
0.25	0.04	0.03	0.02
0.5	0.04	0.03	0.02
1.0	0.04	0.03	0.02
1.5	0.04	0.03	0.02
2.0	0.04	0.03	0.02
2.5	0.04	0.03	0.02
3.0	0.04	0.03	0.02
4.0	0.04	0.03	0.02
5.0	0.04	0.03	0.02

Table F8 - Manning's roughness of a baffled sidewall with baffle spacing, LB=6			
R	Ratio of hydraulic radius of flow to baffle width (R/L)		
(m)	5	10	20
0.25	0.04	0.03	0.02
0.5	0.04	0.03	0.02
1.0	0.04	0.03	0.02
1.5	0.04	0.03	0.02
2.0	0.04	0.03	0.02
2.5	0.04	0.03	0.02
3.0	0.04	0.03	0.02
4.0	0.04	0.03	0.02
5.0	0.04	0.03	0.02

Table F9 - Manning's roughness of a baffled sidewall with baffle spacing, LB=8			
R	Ratio of hydraulic radius of flow to baffle width (R/L)		
(m)	5	10	20
0.25	0.04	0.03	0.02
0.5	0.04	0.03	0.02
1.0	0.04	0.03	0.02
1.5	0.04	0.03	0.02
2.0	0.04	0.03	0.02
2.5	0.04	0.03	0.02
3.0	0.04	0.03	0.02
4.0	0.04	0.03	0.02
5.0	0.04	0.03	0.02

Table F6 to F9 (over page)

Introduction

- The following analysis is based on Knight, D.W. and Macdonald, J.A., 1979. *Hydraulic Resistance of Artificial Strip Roughness*. ASCE Vol 105 HY6, June 1979, pp675-690. American Society of Civil Engineers, USA.
- Knight and Macdonald (1979) developed the following Manning's roughness equation (Equation F1)

$$n = (R/6) / 19.0 * \log_{10} [C * (R/k)] \quad (F1)$$

Equation parameters

- n = Manning's roughness of the baffled sidewall
- R = Hydraulic radius of the culvert cell = A/P [m]
- A = Cross-sectional area of the water flow within the culvert cell [m²]
- P = Wetted perimeter of the water flow within the culvert cell [m]
- C = Equation parameter that depends on the baffle spacing term (k/L)
- L = The horizontal spacing of the baffles = L_B [m]
- k = The projected width of the baffle (including any spacing between the baffle and the culvert sidewall) [m].

Equation parameter 'C'

- The relationship between the equation parameter (C) and the inverse of the baffle spacing term (k/L) is given by:

$$C = 116 * (k/L)^2 - 27.4 * (k/L) + 2.422 \quad (F2)$$

Manning's roughness of a baffled sidewall

- The Manning's roughness for a culvert sidewall lined with rectangular, two-dimensional (strip) roughness units as determined from the work of Knight and Macdonald (1979) is presented in tables F6 to F9.

Table F6 – Manning’s roughness of a baffled sidewall with baffle spacing: $L/k = 2$

R (m)	Ratio of hydraulic radius of flow to baffle depth (R/k)				
	5	10	15	20	30
0.25	0.02	0.02	0.02	0.02	0.02
0.5	0.02	0.02	0.02	0.02	0.02
1.0	0.03	0.02	0.02	0.02	0.02
1.5	0.03	0.03	0.02	0.02	0.02
2.0	0.03	0.03	0.02	0.02	0.02
2.5	0.03	0.03	0.03	0.02	0.02
3.0	0.03	0.03	0.03	0.02	0.02
4.0	0.03	0.03	0.03	0.03	0.02
5.0	0.04	0.03	0.03	0.03	0.03

Table F7 – Manning’s roughness of a baffled sidewall with baffle spacing: $L/k = 4$

R (m)	Ratio of hydraulic radius of flow to baffle depth (R/k)				
	5	10	15	20	30
0.25	0.04	0.03	0.03	0.02	0.02
0.5	0.04	0.03	0.03	0.03	0.02
1.0	0.05	0.04	0.03	0.03	0.03
1.5	0.05	0.04	0.03	0.03	0.03
2.0	0.05	0.04	0.04	0.03	0.03
2.5	0.05	0.04	0.04	0.04	0.03
3.0	0.05	0.04	0.04	0.04	0.03
4.0	0.06	0.05	0.04	0.04	0.03
5.0	0.06	0.05	0.04	0.04	0.04

Table F8 – Manning’s roughness of a baffled sidewall with baffle spacing: $L/k = 6$

R (m)	Ratio of hydraulic radius of flow to baffle depth (R/k)				
	5	10	15	20	30
0.25	0.06	0.04	0.03	0.03	0.03
0.5	0.06	0.05	0.04	0.04	0.03
1.0	0.07	0.05	0.04	0.04	0.03
1.5	0.08	0.05	0.05	0.04	0.04
2.0	0.08	0.06	0.05	0.04	0.04
2.5	0.08	0.06	0.05	0.05	0.04
3.0	0.09	0.06	0.05	0.05	0.04
4.0	0.09	0.06	0.05	0.05	0.04
5.0	0.09	0.07	0.06	0.05	0.05

Table F9 – Manning’s roughness of a baffled sidewall with baffle spacing: $L/k = 10$

R (m)	Ratio of hydraulic radius of flow to baffle depth (R/k)				
	5	10	15	20	30
0.25	0.07	0.05	0.04	0.03	0.03
0.5	0.08	0.05	0.04	0.04	0.03
1.0	0.08	0.06	0.05	0.04	0.04
1.5	0.09	0.06	0.05	0.05	0.04
2.0	0.09	0.06	0.05	0.05	0.04
2.5	0.10	0.07	0.06	0.05	0.04
3.0	0.10	0.07	0.06	0.05	0.05
4.0	0.11	0.07	0.06	0.05	0.05
5.0	0.11	0.07	0.06	0.06	0.05

Research by The University of Queensland (Lang, X. & Chanson, H., 2020)

AUSTRALASIAN JOURNAL OF WATER RESOURCES
2020, VOL. 24, NO. 2, 248–256
https://doi.org/10.1080/13241583.2020.1824367



ARTICLE

How full-height sidewall baffles affect box culvert capacity: balancing fish passage and discharge requirements

Xinqian Leng and Hubert Chanson

^{*}School of Civil Engineering, The University of Queensland, Brisbane, Australia; [†]Laboratoire TREFLE, Presently: Université de Bordeaux, I2M, Pessac, France

ABSTRACT

Low-level river crossings and culverts deliver valuable transportation and hydraulic control services to the society, but have negative impacts in terms of upstream fish passage. Recently, full-height sidewall baffles have been imposed in north-eastern Australia to assist upstream passage of small-bodied fish in box culverts, although the impact on the culvert discharge capacity was ignored. Detailed physical modelling was conducted under controlled flow conditions in a near-fullscale culvert barrel channel, equipped with such full-height sidewall baffles. The results provide a quantitative assessment of the impact of full-height sidewall baffles on the discharge capacity of box culverts. Applications were developed for single- and multi-cell box culverts, and practical implications are discussed.

ARTICLE HISTORY

Received 1 February 2020
Accepted 23 August 2020

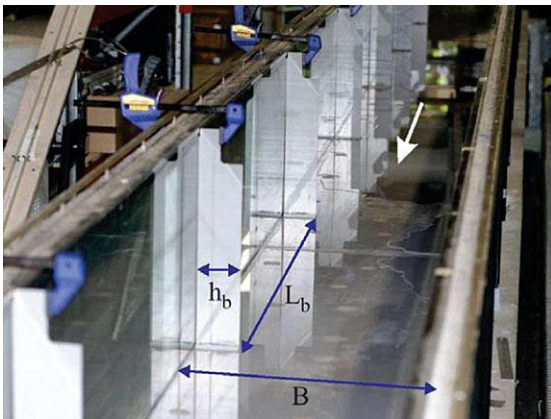
KEYWORDS
Box culverts; sidewall baffles; upstream fish passage; discharge capacity; low-velocity zone; maintenance

1. Introduction

Low-level river crossings, including culverts (Figure 1 (a)), are important for delivering a range of valuable socioeconomic services, including transportation and hydrological control. These structures are also known to have negative impacts on freshwater river system morphology and ecology, including the blockage of upstream fish passage, particularly weak-swimming

culvert barrel channel, equipped with such full-height sidewall baffles. The measurements delivered a fine characterisation of the hydrodynamics of the baffled channel, acting as a box culvert barrel. The results provide a quantitative assessment of the impact of full-height sidewall baffles on the discharge capacity of box culverts. Applications are later developed for both multi- and single-cell box culverts.

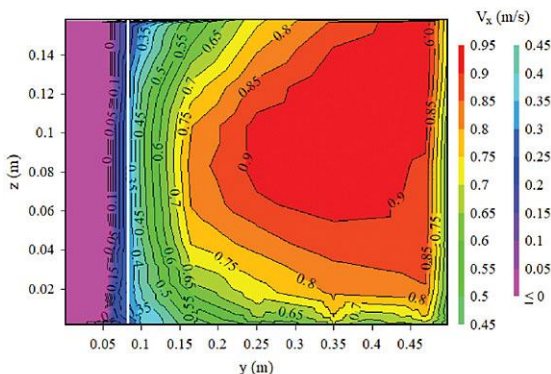
Leng & Chanson, 2020



Leng & Chanson (Figure 1)



Leng & Chanson (Figure 2)



Leng & Chanson (Figure 5)

How full-height sidewall baffles affect box culvert capacity: balancing fish passage and discharge requirements

- Xinqian Leng and Hubert Chanson
- School of Civil Engineering, The University of Queensland.
- Australasian Journal Of Water Resources, 2020, Vol. 24, No. 2, 248–256.

Testing flume

- Parameters defined.

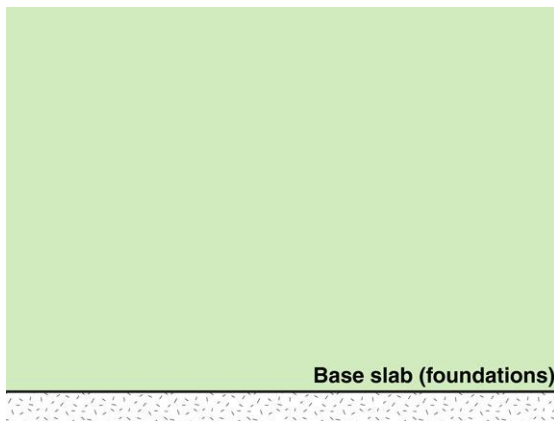
Hydraulic test

- Note that a space exists between the baffle and the sidewall.

Flow velocity profile

- Typical test result.

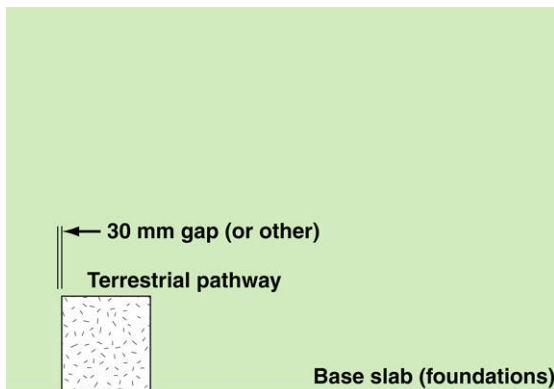
F6 - Possible Construction Steps



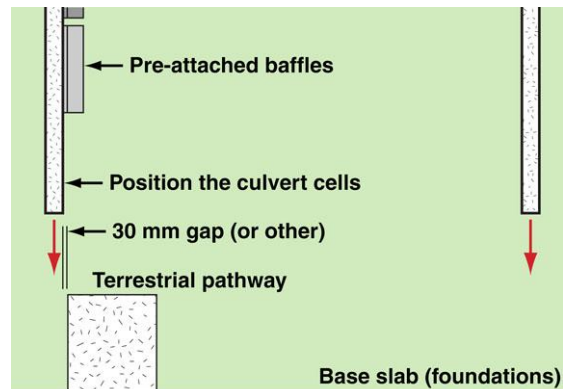
Foundations

Construction steps

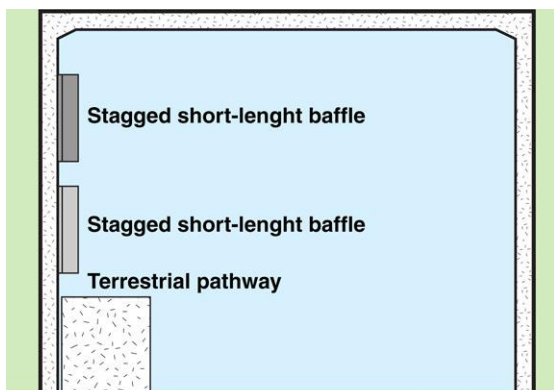
- It is not the intent of this document to specify a certain construction procedure.
- Presented simply as a guide; the following procedure could be followed:
 - form foundations (the base slab)
 - form the terrestrial pathway
 - attach baffles to the individual culvert cells prior to installation
 - install culvert cells
 - install the lizard run (alternatively, install in sections prior to cell placement).



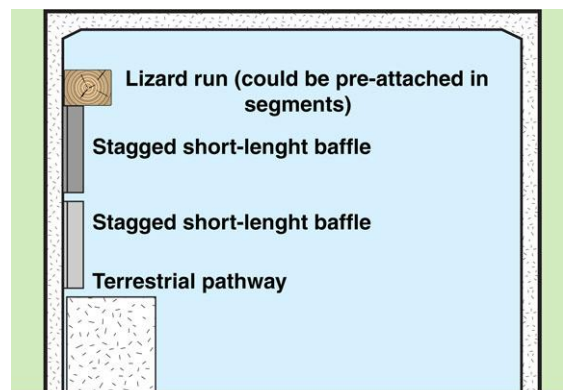
Terrestrial pathway



Placement of culvert cells



Placement of culvert cells



Install elevated lizard run

