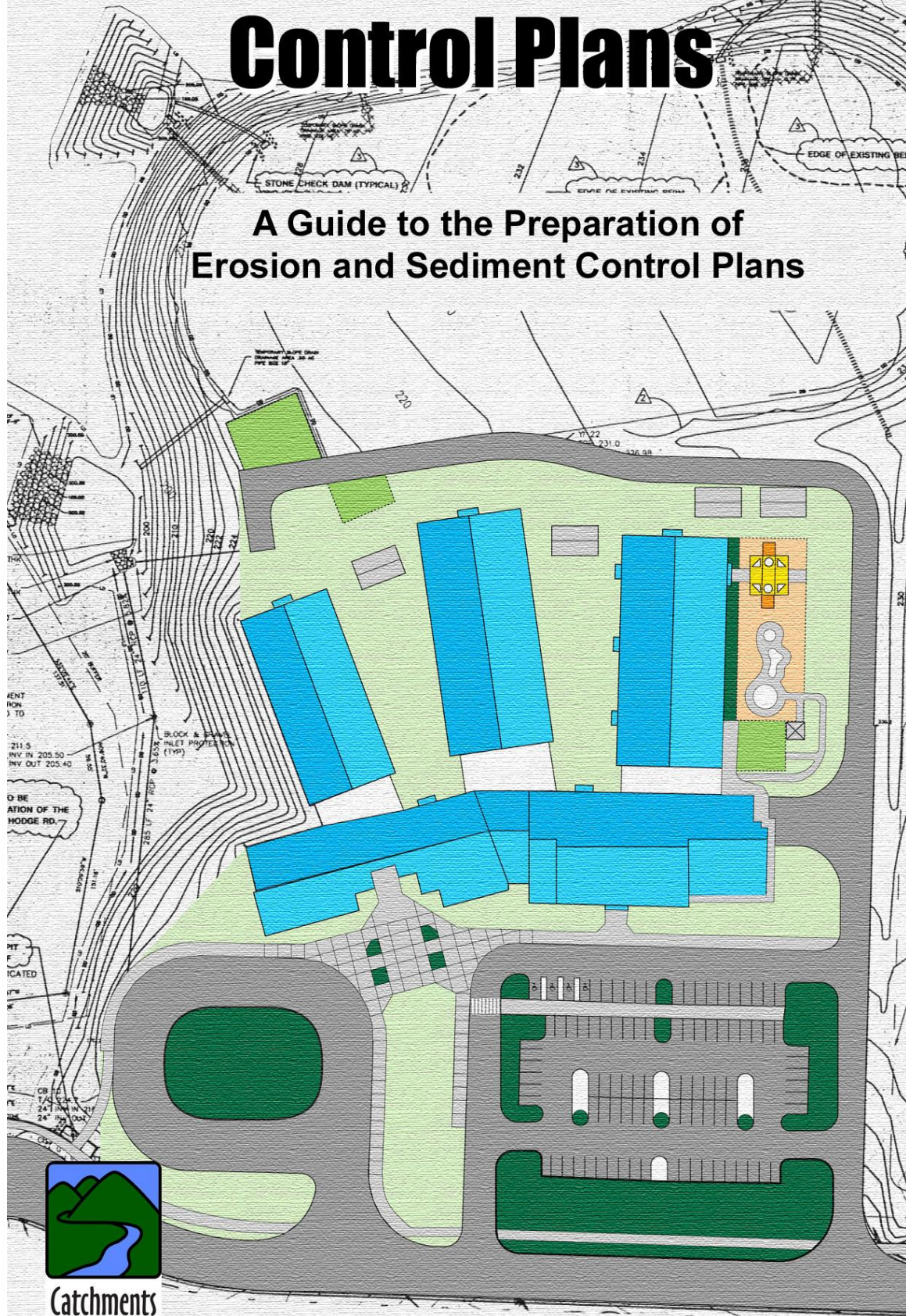


# Erosion and Sediment Control Plans

A Guide to the Preparation of  
Erosion and Sediment Control Plans



Catchments  
& Creeks

Version 2, 2026

# **Erosion and Sediment Control Plans**

## **A Guide to the Preparation of Erosion and Sediment Control Plans**

Version 2, May 2026

Written and illustrated by: Grant Witheridge, Catchments and Creeks

Published by: Catchments and Creeks, Bargara, Queensland

Except as permitted under copyright laws, no part of this publication may be reproduced within another publication without the prior written permission of the publisher.

Permission, however, is granted for users to:

- store the complete document on a database, but not isolated parts of the document
- print all, or part, of the document, and distribute such printed material to a third party
- distribute the complete document in electronic form to a third party, but not isolated parts of the document.

All diagrams are supplied by Catchments and Creeks and remain the ownership of Catchments & Creeks. No diagram or photograph may be reproduced within another publication without the prior written permission of the Director of Catchments and Creeks.

This document should be referenced as:

Witheridge 2026, *Erosion and Sediment Control Plans – A Guide to the Preparation of Erosion and Sediment Control Plans*. Catchments and Creeks, Bargara, Queensland

Key words: erosion and sediment control, erosion and sediment control plans, construction schedule, construction drainage plans, ESC Plans, ESCP.

Copies of this document may be downloaded from: [www.catchmentsandcreeks.com.au](http://www.catchmentsandcreeks.com.au)

Cover: The original Erosion and Sediment Control Plan prepared for Hodge Road Elementary School, Wake County, North Carolina, USA in 1994; however, with drawings of buildings and car park added as an overlay.

© Catchments & Creeks, 2026

### **Disclaimer**

Significant effort has been taken to ensure that this document is representative of current best practice erosion and sediment control; however, the author cannot and does not claim that the document is without error, or that the recommendations presented within this document will not be subject to future amendment.

To be effective, erosion and sediment control measures must be investigated, planned, and designed in a manner appropriate for the given work activity and site conditions.

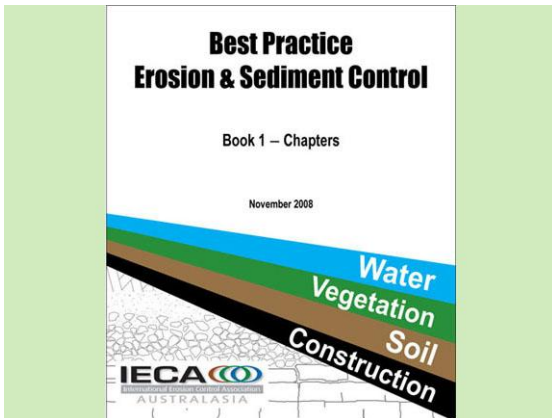
No warranty or guarantee, express, implied, or statutory is made as to the accuracy, reliability, suitability, or results of the methods or recommendations.

The author shall have no liability or responsibility to the user or any other person or entity with respect to any liability, loss, or damage caused, or alleged to be caused, directly or indirectly, by the adoption and use of any part of the document, including, but not limited to, any interruption of service, loss of business or anticipatory profits, or consequential damages resulting from the use of the document.

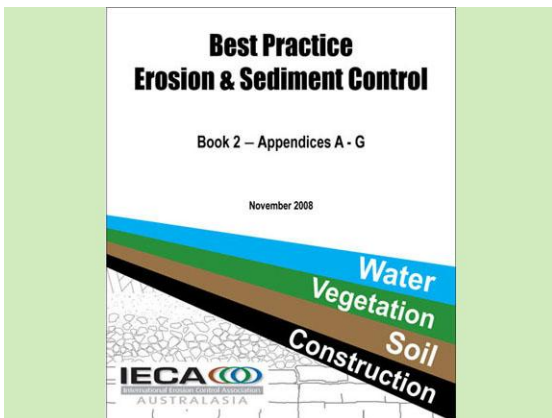
Specifically, adoption of the recommendations and procedures presented within this document will not guarantee:

- (i) compliance with any statutory obligations
- (ii) compliance with specific water quality objectives
- (iii) avoidance of environmental harm or nuisance.

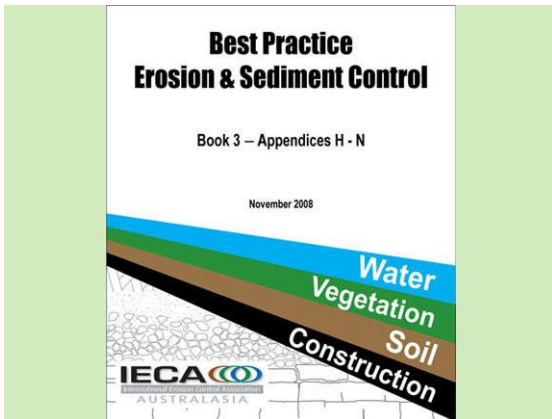
## Principal reference documents



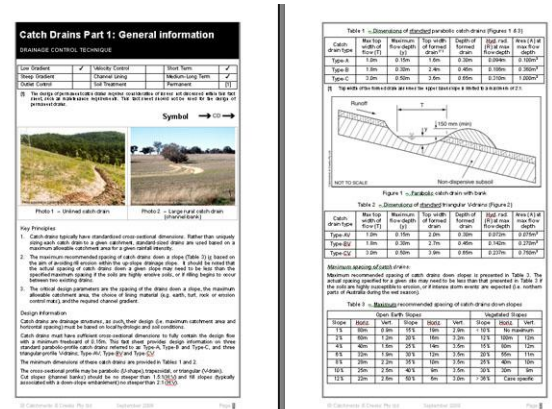
IECA (2008) – Book 1



IECA (2008) – Book 2



IECA (2008) – Book 3



ESC Technique Fact Sheets

### Best Practice Erosion & Sediment Control. International Erosion Control Association, (IECA) Australasia Chapter, 2008

1. Introduction
2. Principles of erosion and sediment control
3. Site planning
4. Design standards and technique selection
5. Preparation of plans
6. Site management
7. Site inspection
8. Bibliography

### Book 2: Appendices

- A. Construction site hydrology and hydraulics
- B. Sediment basin design and operation
- C. Soils and revegetation
- D. Example plans
- E. Soil loss estimation
- F. Erosion hazard assessment
- G. Model code of practice

### Book 3: Appendices

- H. Building sites
- I. Instream works
- J. Road and rail construction
- K. Access tracks and trails
- L. Installation of services
- M. Erosion processes
- N. Glossary of terms
- P. Land-based pipeline construction
- X. Index (Books 1 to 3)

### Book 4 design fact sheets are grouped as:

- Drainage control measures
- Erosion control measures
- Sediment control measures
- De-watering sediment control measures
- Instream work practices

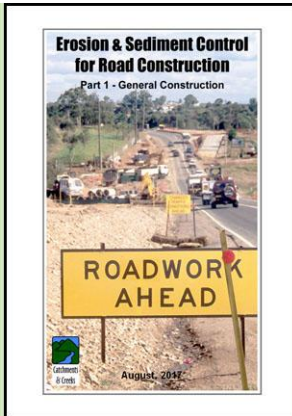
### Download the fact sheets from:

[www.austieca.com.au](http://www.austieca.com.au)

[www.catchmentsandcreeks.com.au](http://www.catchmentsandcreeks.com.au)

Standard Drawings are also available.

## Associated *Catchments and Creeks* documents

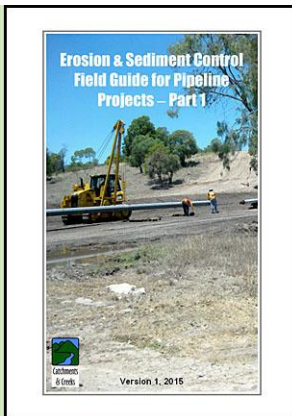


**Field Guide for Road Construction**

### *Erosion & Sediment Control Field Guide for **Road Construction***

Parts 1 and 2.

Witheridge, G.M. 2017, Catchments and Creeks Pty Ltd., Brisbane, Queensland.



**Field Guide for Pipeline Projects**

### *Erosion & Sediment Control Field Guide for **Pipeline Projects***

Parts 1 and 2.

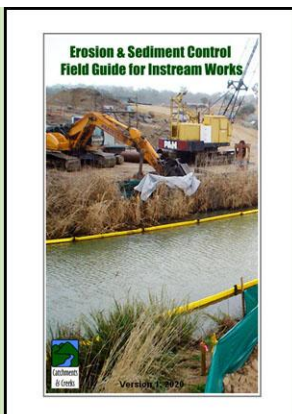
Witheridge, G.M. 2015, Catchments and Creeks Pty Ltd., Brisbane, Queensland.



**Construction Site Sediment Basins**

### *Construction Site **Sediment Basins***

Witheridge, G.M. 2022, Catchments and Creeks Pty Ltd., Bargara, Queensland.



**Field Guide for Instream Works**

### *Erosion & Sediment Control Field Guide for **Instream Works***

Witheridge, G.M. 2020, Catchments and Creeks Pty Ltd., Bargara, Queensland.

<b>Contents</b>	<b>Page</b>
Purpose of document	7
About the author	7
Introduction	7
Types of Erosion and Sediment Control Plans	8
Design team	9
The aim of erosion and sediment control	10
Problems to avoid when preparing an ESCP	11
Suggested ESCP technique codes	15
<b>1. Preliminary and Conceptual Erosion and Sediment Control Plans</b>	
Introduction	18
Conceptual Erosion and Sediment Control Plans	20
Generic Erosion and Sediment Control Plans	21
Hodge Road Elementary School, Knightdale, North Carolina, USA	22
<b>2. Preparation of Erosion and Sediment Control Plans</b>	
Introduction	29
Possible contents of an ESCP	30
Development of plans that can adapt to changing seasons	31
Balancing drainage, erosion, and sediment controls	32
Suggested steps in the development of an ESCP	34
Case Study - Hodge Road Elementary School background information	35
Step 1 - Review local issues, concerns and site constraints	37
Step 2 - Review the development layout	39
Step 3 - Review soil data	41
Step 4 - Prepare a cut and fill plan	43
Step 5 - Prepare a Construction Drainage Plan	45
Step 6 - Locate traffic entry/exit points and associated ESC measures	47
Step 7 - Locate and protect the site office and stockpile areas	49
Step 8 - Identify potential areas of non-disturbance	52
Step 9 - Review access roads and temporary watercourse crossings	53
Step 10 - Determine the required sediment control standard	55
Step 11 - Locate major sediment traps	60
Step 12 - Review proposed staging of works	67
Step 13 - Control 'clean' water run-on and runoff	68
Step 14 - Control erosion within all drains	71
Step 15 - Control 'dirty' water runoff	75
Step 16 - Control soil erosion on all disturbed areas	78
Step 17 - Establish sediment traps within the development	82
Step 18 - Control sediment runoff at the property boundary	96
Step 19 - Define the final limits of disturbance	99
Step 20 - Prepare the site revegetation/rehabilitation plan	100
Step 21 - Prepare the installation sequence	102
Step 22 - Specify emergency ESC measures	104
Step 23 - Prepare the Monitoring and Maintenance Program	106
Step 24 - Prepare Inspection and Test Plans	107
Step 25 - Supporting documentation	109

ESCP signature box	110
Construction contracts	111
Case Study – Hodge Road Elementary School, Final ESCP	112
Case Study – Hodge Road Elementary School, Alternative ESCP	114
Example technical notes	115
<b>3. Road Construction</b>	
Introduction	124
Key issues on road construction projects	125
Construction of a local road	126
Construction of a neighbourhood road	127
Construction of a dual carriageway	128
Assessing the need for a sediment basin	129
Locating major sediment traps	130
Case Study – Road construction over a piped drainage line	131
<b>4. Culvert and Bridge Construction</b>	
Introduction	136
Issues	137
Site issues that can influence the construction procedure	138
Road construction across a drainage line (non-waterway)	139
Site issues that can influence the crossing of waterways	141
Use of cofferdams	142
Culvert construction	143
Fish passage considerations	144
Culvert construction using isolation barriers ( <a href="#">Examples 1 &amp; 2</a> )	145
Types of isolation barriers	146
<a href="#">Example 3</a> - Culvert construction with public bypass road	147
<a href="#">Example 4</a> - Sediment basins located within the road corridor	148
Sediment controls for road construction over waterways	150
Example bridge construction	152
<b>5. Instream Work Practices</b>	
Introduction	156
Consideration of alternative work procedures	157
Pipe crossings of waterways	159
Erosion and Sediment Control Plans	162
Erosion and Sediment Control Plan (example template)	163
Case Study - Creek bank stabilisation, Grovely, Qld	164
<b>6. Erosion and Sediment Control Plan Checklist</b>	169
<b>7. Glossary of terms</b>	178

## Purpose of document

This document has been prepared specifically to:

- provide training for ESC practitioners on the preparation of Erosion and Sediment Control Plans
- provide examples of Erosion and Sediment Control Plans (ESCPs); however, none of the plans presented in this document are suitable as actual construction plans—the detail shown on the example plans has been altered to make it suitable for presentation as an A4-sized diagram.

The photos presented within this document are intended to represent the current topic of discussion. These photos are presented for the purpose of depicting either a preferred or discouraged outcome (as the case may be). In some cases the photo may not represent current best practice, but is simply the best photo available to the author at the time.

The caption and/or associated discussion should **not** imply that the site shown within the photograph represents either good or bad land management practice. The circumstances, site conditions and history of each site are not known in each case, and may not be directly relevant to the current discussion. This means that there may be a valid site-specific reason why the designer chose the control device or treatment method depicted in the photo.

## About the author

Grant Witheridge is a [retired](#) civil engineer with both Bachelor and Masters degrees from the University of NSW (UNSW). He has over 40 years experience in the fields of hydraulics, creek engineering and erosion & sediment control, during which time he has worked for a variety of federal, state and local governments, as well as private organisations.

Grant is the principal author of such publications as the IECA (Australasia) *Best Practice Erosion and Sediment Control (2008)* documents and revising of the *Queensland Urban Drainage Manual (2007, 2013 & 2017)*. In 2010 Grant was presented with the IECA (International) *Sustained Contributor Award*.

## Introduction

The appropriate design of erosion and sediment control (ESC) measures does not end with the production of an [Erosion and Sediment Control Plan \(ESCP\)](#). The process of updating the ESCP as site conditions change must continue until stable land conditions are achieved.

ESCPs are prepared specifically for the purpose of detailing the proposed erosion and sediment control measures for a particular building or construction site. Typically these plans detail only short-term measures. Permanent sediment control, stormwater management, and landscaping measures are normally detailed within the site's Stormwater Management and Landscaping Plans.

As a complete package, an ESCP may consist of several components including plans and supporting documentation. The ESCP package may consist of the following:

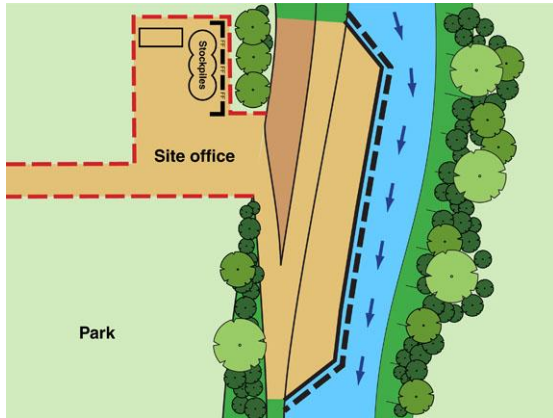
- Erosion and Sediment Control Plans
- Supporting documentation
- Specifications and construction details for ESC measures.

### Terminology:

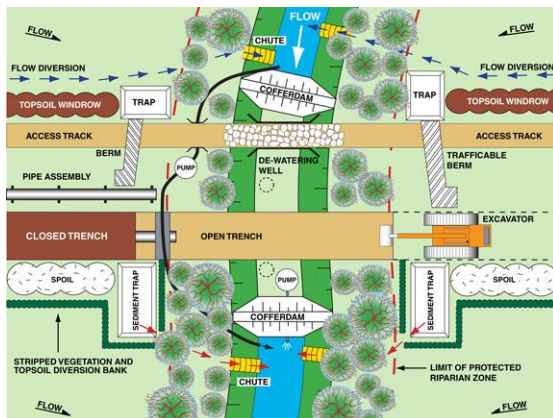
Erosion and Sediment Control Plan (ESCP) is the term most commonly used to describe those plans that demonstrate proposed erosion and sediment control practices. These plans, however, can attract a variety of different names within different authorities, including Soil Erosion and Drainage Management Plans (SEDMPs), Soil and Water Management Plans (SWMPs), Soil Erosion and Sediment Control Plans (SESCPs), Erosion and Sediment Control Programs (ESC Programs) and Conceptual Erosion and Sediment Control Plans.

An Erosion and Sediment Control Plan checklist is provided at the end of the document.

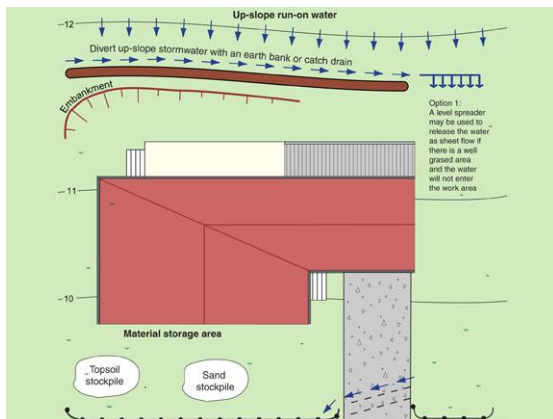
## Types of Erosion and Sediment Control Plans



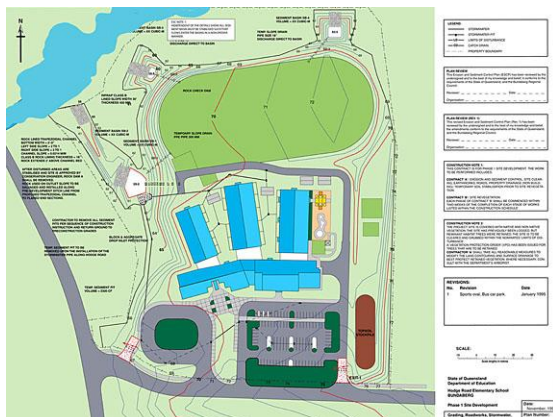
Conceptual ESCP for instream works



Generic ESCP for minor pipe crossing



Building site ESCP



Site Specific ESCP

### Conceptual ESCPs

- Conceptual Erosion and Sediment Control Plans are prepared when a proposed development is considered to be high risk.
- If, during the **planning stage** of a development, it has been identified that the proposal could result in significant environmental harm, then the developer may be asked to demonstrate that there is a potential solution to this issue.
- These conceptual plans are typically modified during the design phase.

### Generic ESCPs

- Generic ESCPs present the types of ESC measures that are considered appropriate for those **low-risk** maintenance and construction activities that are **regularly** carried out by councils and utility companies.
- Examples of such work include:
  - replacement of stormwater pits
  - repair of pipe failures
  - road and drainage maintenance.

### Building site ESCPs

- Most building site ESCPs are very simple plans that generally do not need to be prepared by a certified ESC professional (check with your local authority).
- These plans are unlikely to contain supporting documentation.
- The focus of these plans can be on simply reducing the generation of mud, and its possible transportation off the site.
- **Building site ESCPs are not discussed in this document.**

### Site Specific ESCPs

- Site Specific ESCPs are normally prepared by Certified Professionals in Erosion and Sediment Control (CPESC).
- It is the preparation of these plans that forms the basis of this document.

### Terminology:

- **ESC** means 'erosion and sediment control'
- **ESCP** and **ESC Plan** means 'Erosion and Sediment Control Plan'.

## Design team



**Construction personnel**



**Engineering professionals**



**Scientific officers**



**Site inspection**

## Construction personnel

- The preparation of *Erosion and Sediment Control Plans* for construction projects is typically not a one-person task.
- To avoid expensive, impractical, or ineffective outcomes, the design team should include a range of experts.
- **Key** to the production of practical outcomes is the inclusion of advice from people experienced in construction procedures, i.e. achieving a practical outcome.

## Engineering advice

- Individual engineers specialise in different fields of engineering, and not all engineers have appropriate construction experience.
- Engineering advice is typically required on:
  - catchment hydrology and hydraulics
  - geotechnical engineering and embankment design (e.g. basins)
  - engineering issues relating to specialist activities such as waterway crossings.

## Science advice

- Specialist advice may be required on the following issues:
  - soil science
  - fish passage and fish biology
  - environmental protection
  - waterway ecology
- The knowledge base found within the soil science profession is different from that found within geotechnical engineering; however, specialist consultancies typically employ both professionals.

## Revegetation advice

- Revegetation contractors are different from landscape architects and botanists.
- Some revegetation contractors specialise solely in the operation of planting/seeding equipment, while others may also have detailed knowledge of plant selection and soil conditioning.
- The knowledge base and experience of the revegetation contractor will have a **significant** influence on both the rate of plant establishment, and the long-term revegetation outcomes.

## The aim of erosion and sediment control



Knowing what is the right thing to do



Photo supplied by Catchments & Creeks Pty Ltd.

Coarse sediment trapped on-site



Photo supplied by Catchments & Creeks Pty Ltd.

Sand-based waterway



Photo supplied by Catchments & Creeks Pty Ltd.

This shows 60% coverage of the soil

### Introduction

- One of the hardest things to learn in the erosion and sediment control industry is that the primary aim is:
  - not to solely minimise the release of sediment, but instead . .
  - to **minimise environmental harm**.
- Of course, many people will point out that minimising environmental harm requires construction sites to minimise the release of sediment, but consider the following.

### Consider this example

- If an active construction site were to install numerous **effective** sediment fences across a work site, then at best they may capture 90% of the coarse sediment released within the work site.
- However, such an approach would likely capture no more than 10% of the clay-sized particles (i.e. the turbidity).
- Now if 90% of the environmental harm is caused by turbidity, then those sediment fences would have only prevented only 9% of the environmental harm!

### Understanding what it is that you are trying to protect

- Releasing '**sand**' into a sand-based waterway is unlikely to cause harm, but releasing silts, clays or turbidity into the same waterway would cause harm.
- Releasing '**turbidity**' into an arid waterway, that is 'naturally' very turbid, is unlikely to cause harm, but releasing coarse sediment into such waterways could block the channel and cause the diversion of flood flows, which could increase the potential for flood damage.

### Looking down-slope, and downstream of the work site

- You cannot determine what is important by only observing the construction site.
- Minimising soil loss from a work site, or a farm, is an admirable goal, which can be achieved with just 70% cover of the soil.
- However, in **some** environments, minimising environmental harm can require as much as 90%, or even 100% coverage of all soils in order to minimise raindrop impact erosion, and the release of highly-turbid runoff.

## Problems to avoid when preparing an ESCP



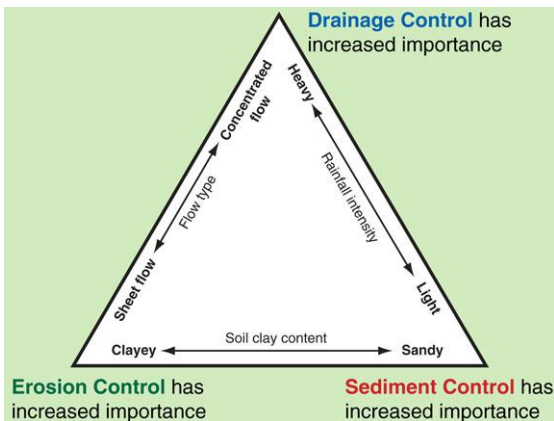
Photo supplied by Brisbane City Council

**Appropriate use of a straw bale**



Photo supplied by Catchments & Creeks Pty Ltd

**Turbid water in neighbour's farm dam!**



Erosion Control has increased importance  
Sediment Control has increased importance

**Drainage, erosion and sediment control**



Photo supplied by Catchments & Creeks Pty Ltd

**Inappropriate use of sediment fences**

### Introduction

- Firstly it is important to remember that there is almost always an exception to every rule.
- The 'common problems' discussed over the following pages are presented for general discussion only.
- These statements (rules) should not be taken as absolute facts, because **there is almost always an exception to every rule.**

### The wrong focus

- It is common for practitioners to focus on minimising the release of sediment.
- However, the real focus should be on minimising the risk of **environmental harm.**
- It is important to understand what the actual threats are to downstream environments—is it 'sand', 'silt, or 'clay'?
- There is little value in trapping all the coarse sediment in sediment traps if the real harm is being caused by the clays released by raindrop impact erosion.

### Using all three tool boxes

- Erosion and Sediment Control Plans should **not** focus solely on the deployment of sediment control measures.
- Without effective **drainage control**, most sediment control measures will fail during a heavy rainfall.
- Even though most sediment controls are ineffective during heavy rainfall, it is important that these devices **do not structurally fail** and release their trapped sediment during such storm events.

### Excessive use of sediment fences

- There is an informal, but often stated observation, that a well-prepared ESCP will have very few sediment fences.
- Inexperienced ESC practitioners can commence the drafting of their ESCP by positioning sediment fences along most of the property boundaries, and along all road reserves.
- Such excessive use of sediment fences is:
  - ineffective, and
  - financially wasteful.

## Problems to avoid when preparing an ESCP



Photo supplied by Catchments & Creeks Pty Ltd

**Sediment fence located in bushland**

### Placing sediment controls inside non-disturbance areas

- When preparing an Erosion and Sediment Control Plan, non-disturbance areas usually appear on the base plan as empty spaces of 'white', possibly with the exception of a few land contour lines.
- Unless appropriately identified, it can be easy to forget that these 'empty' spaces represent retained vegetation.
- This can lead designers to mistakenly place sediment controls within these areas, which is a No-no!



Photo supplied by Catchments & Creeks Pty Ltd

**Severe erosion on a newly grassed area**

### Ignoring the potential harm caused by raindrop impact erosion

- I have had land owners claim that their deforested land is not subject to soil erosion because:
  - the land is very flat, and
  - the USLE's LS-factor = 0.0
- However, the facts are that any soil that is exposed to raindrop impact, no matter how 'flat,' or 'compact,' the soil is, will be subject to erosion, and potentially the release of turbid runoff.

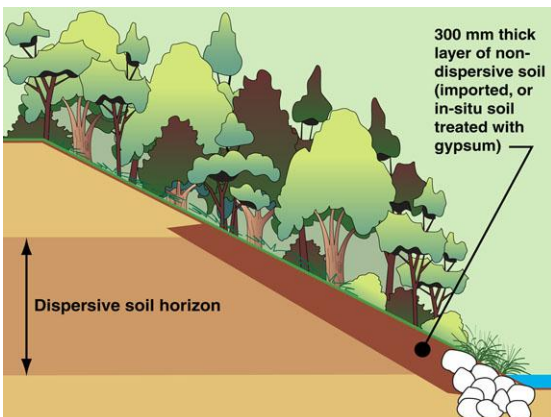


Photo supplied by Catchments & Creeks Pty Ltd

**Fully exposed road batter**

### Confusing 'erosion control' objectives with 'site revegetation'

- Too many work sites have **finished earthworks** that are left exposed to erosion simply because the earthworks contract, and/or the ESCP, specifies that:
  - erosion control measures consist solely of site revegetation, and
  - site revegetation is to be performed by a separate contractor.
- ESCPs must identify what erosion control measures must be applied prior to site revegetation/long-term stabilisation.



**Stabilisation of a dispersive soil**

### Failing to document the appropriate treatment of dispersive soils

- The exact location of dispersive soils may not be known at the time the proposed works are being designed.
- When detailing site revegetation, bank stabilisation, or even topsoil placement, it is often assumed that the exposed soils are non-dispersive.
- ESCPs must include technical notes that inform contractors of the steps that need to be taken if dispersive soils are identified on the work site.

## Problems to avoid when preparing an ESCP



Photo supplied by Catchments & Creeks Pty Ltd

**Approaching storm**

### Failure to document what ESC measures are required if the site is active during the wet season

- There are some regions of Australia, and parts of the world, where there are periods within a year when rainfall is highly unlikely to occur.
- In these regions it is common for ESC requirements to be relaxed during these dry periods because the risk of environmental harm is so low.
- However, ESCPs must include notes on preparing the site for wet weather.



Photo supplied by Catchments & Creeks Pty Ltd

**Temporary access road**

### Failure to identify temporary construction activities and the ESC measures

- If the ESC Plan is being prepared over a base plan that shows only the **final** layout of the development, then it is possible for the design team to miss such things as:
  - site office and car park
  - soil stockpiles and borrow pits
  - material storage areas
  - temporary access roads.
- This photo shows a temporary access road with no ESC measures specified.



Photo supplied by Catchments & Creeks Pty Ltd

**Inappropriate on-grade inlet control**

### Failure to identify the different treatment of 'sag' and 'on-grade' stormwater pits

- Roadside stormwater pits can either be located at low points on a road (sags), or along a grade (on-grade pits).
- During the construction phase it is common for 'drop inlet sediment traps' to be installed adjacent to, or around, these stormwater inlets.
- Unfortunately, many ESCPs fail to identify which type of sediment traps are required around each type of kerb inlet.

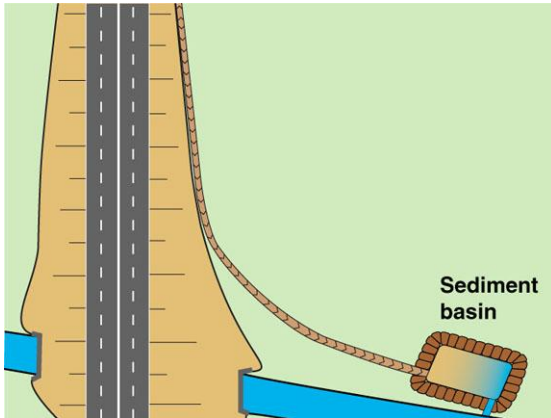


**Complex road construction**

### Preparing a single ESCP when the site has several major stages of earthworks

- Multi-stage earthworks require a separate ESCP for each stage of earthworks.
- The movement of 'dirty' water runoff can change significantly as new and old embankments are constructed or removed.
- For example, existing roadways may ultimately be removed, but while they remain in place they can alter the movement of water across the work site.

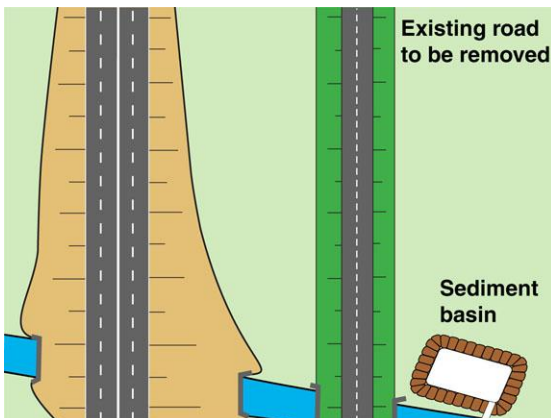
## Problems to avoid when preparing an ESCP



Proposed ESC layout (old road not shown)

### The Problem!

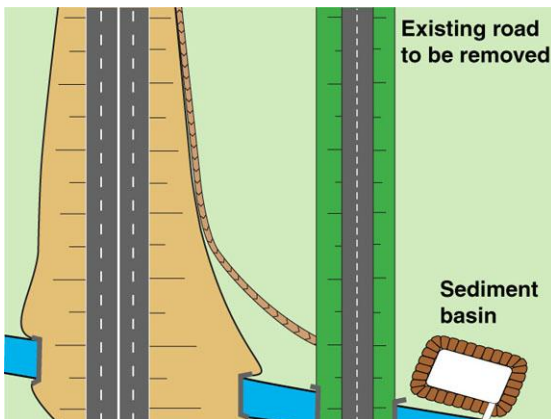
- Erosion and Sediment Control Plans are often prepared with only the **final** development layout being used as the base drawing.
- Consider this example, which mimics an actual case.
- The project involved the construction of a new highway parallel to the existing highway, which will be removed upon completion of the new road.



Actual site with sediment basin built

### During construction of the new highway, the old road may be required to remain open to the public

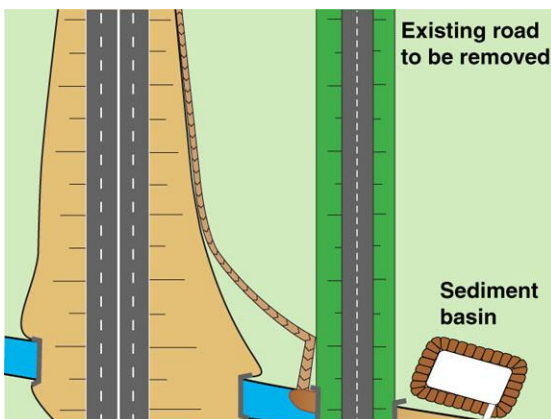
- In order to prepare an effective Erosion and Sediment Control Plan, the base plan must include information on the existing road embankment.
- If the existing road embankment is not identified on the base plan, then it is difficult to know where water will flow.



Construction of dirty water drain

### The problem

- The resulting outcome was a sediment basin separated from the active construction area by the existence of the old roadway.
- This sediment basin (which would have been fully funded under the earthworks contract) was only active after the old road had been removed.



Resulting sediment flow into waterway

### The outcome

- The outcome was an amended ESCP, and the funding of new sediment controls.
- Bad news for the ESCP designer.
- Bad news for the government.
- Good (financial) reward for the earthworks contractor!

## Suggested ESCP technique codes

The following ESCP technique codes are provided only as a suggestion (not mandatory).

**Table 1a – A to Z of ESC technique identification codes**

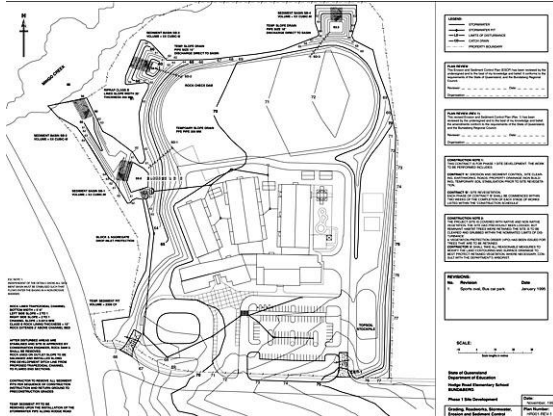
Code	Technique	Technique grouping
BB	Brushwood Barrier	Sediment Control (Supplementary)
BA	Block & Aggregate Drop Inlet Protection	Sediment Control (Type 2)
BFM	Bonded Fibre Matrix	Erosion Control
BZ	Buffer Zone	Sediment Control (Type 1, 2 or 3)
CB	Compost Berm	Sediment Control (Type 2)
CBT	Compost Blanket	Erosion Control
CCS	Cellular Confinement System	Drainage & Erosion Control
CD	Catch Drain	Drainage Control
CDT	Check Dam Sediment Trap	Sediment Control (Supplementary)
CH	Chute	Drainage Control
CST	Coarse Sediment Trap	Sediment Control (Type 3)
Dam	Cofferdam	Instream Control – flow control
DB	Flow Diversion Bank	Drainage Control
DC	Diversion Channel	Drainage Control
Dust	Dust Control	Erosion Control
ECB	Erosion Control Blanket	Erosion Control
ECM	Erosion Control Mats	Drainage Control – channel lining
EX	Excavated Drop Inlet Protection	Sediment Control (Type 3)
Exit	Construction Exit	Sediment Control (Supplementary)
Exit	Rock Pad	Sediment Control (Supplementary)
Exit	Vibration Grid	Sediment Control (Supplementary)
Exit	Wash Bay	Sediment Control (Supplementary)
FB	Filter Bag	De-watering Sediment Control (Type 2)
FD	Fabric Drop Inlet Protection	Sediment Control (Type 3)
FF	Filter Fence	De-watering Sediment Control (Type 3)
FP	Filter Pond	De-watering Sediment Control (Type 2)
FR	Fibre Roll	Drainage & Sediment Control (Sup.)
FS	Filter Sock	Sediment Control (Type 2 or 3)
FSC	Floating Silt Curtain	Instream Control – flow control
FT	Filter Tube	De-watering Sediment Control (Type 2)
FTB	Filter Tube Barrier	Instream Control (Type 2)
FTD	Filter Tube Dam	De-watering & Sediment Control (Type 2)
FW	Fabric Wrap Drop Inlet Protection	Sediment Control (Type 3)
G	Gravelling	Erosion Control
GB	Gully Bag	Sediment Control (Supplementary)
GC	Grass Lining	Drainage Control – channel lining
GEO	Geosynthetic Lining	Drainage Control – channel lining
GFB	Grass Filter Bed	De-watering Sediment Control (Type 3)
GFS	Grass Filter Strip	Sediment Control (Supplementary)
GP	Grass Pavers	Erosion Control
HA	Hard Armouring	Drainage Control – channel lining
IB	Isolation Barrier	Instream Control – flow control
Log	Geo Log	Instream Control – flow control

**Table 1b – A to Z of ESC technique identification codes (continued)**

<b>Code</b>	<b>Technique</b>	<b>Technique grouping</b>
LS	Level Spreader	Drainage Control
M	Light Mulching	Erosion Control
MA	Mesh & Aggregate Drop Inlet Protection	Sediment Control (Type 2)
MB	Mulch Berm	Sediment Control (Type 2)
MH	Heavy Mulching	Erosion Control
MR	Rock Mulching	Erosion Control
MSB	Modular Sediment Barrier	Instream Control (Type 3)
MST	Modular Sediment Trap	Sediment Control (Type 3)
OG	Kerb Inlet Trap – On-Grade Inlets	Sediment Control (Supplementary)
OS	Outlet Structure	Drainage Control
OW	Spill-Through Weir	Sediment Control (component)
Poly	Polyacrylamide	Erosion Control
PST	Portable Sediment Tank	De-watering Sediment Control (Type 2/3)
R	Revegetation	Erosion Control
RA	Rock & Aggregate Drop Inlet Protection	Sediment Control (Type 2)
RC	Rock Check Dam	Drainage Control
RFD	Rock Filter Dam	Instream & Sediment Control (Type 2)
RM	Rock Mattress Lining	Drainage Control – channel lining
RR	Rock Lining	Drainage Control – channel lining
RRC	Recessed Rock Check Dam	Drainage Control
SA	Kerb Inlet Trap – Sag Inlets	Sediment Control (Supplementary)
SB	Sediment Basin	Sediment Control (Type 1)
SBB	Straw Bale Barrier	Sediment Control (Type 3)
SBC	Sandbag Check Dam	Drainage Control
SBS	Soil Binder	Erosion Control
SD	Slope Drain	Drainage Control
SEP	Settling Pond	De-watering Sediment Control (Type 2)
SF	Sediment Fence	Sediment Control (Type 3)
SFB	Sediment Fence Isolation Barrier	Instream Control – flow control
SFC	Sediment Filter Cage	Instream Control (Type 3)
SGB	Stiff Grass Barrier	Sediment Control (Supplementary)
SP	Sump Pit	De-watering Sediment Control (Type 2)
SR	Surface Roughening	Erosion Control
SS	Sediment Trench	Sediment Control (Type 2)
ST	Sediment Trap	Sediment Control
STP	Stilling Pond	De-watering Sediment Control (Type 1)
SW	Sediment Weir	Instream & Sediment Control (Type 2)
T	Turfing	Drainage & Erosion Control
TBC	Temporary Bridge Crossing	Drainage Control
TCC	Temporary Culvert Crossing	Drainage Control
TD	Temporary Downpipe	Drainage Control
TDC	Triangular Ditch Check	Drainage Control
TFC	Temporary Ford Crossing	Drainage Control
TRM	Turf Reinforcement Mat	Drainage Control – channel lining
TS	Temporary Seeding	Erosion Control
TWC	Temporary Watercourse Crossing	Drainage Control
UST	U-Shape Sediment Trap	Sediment Control (Type 3)

# **1. Conceptual and Generic Erosion and Sediment Control Plans**

## Introduction

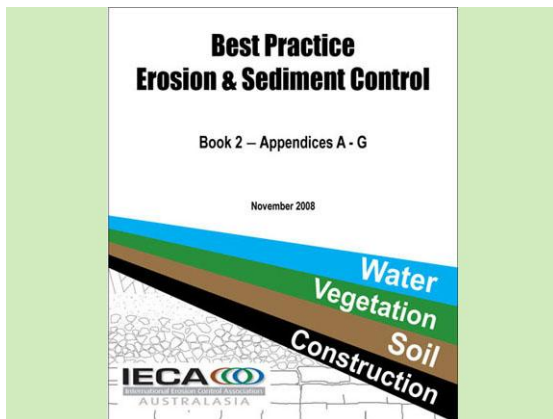


Preliminary ESCP for the Case Study site

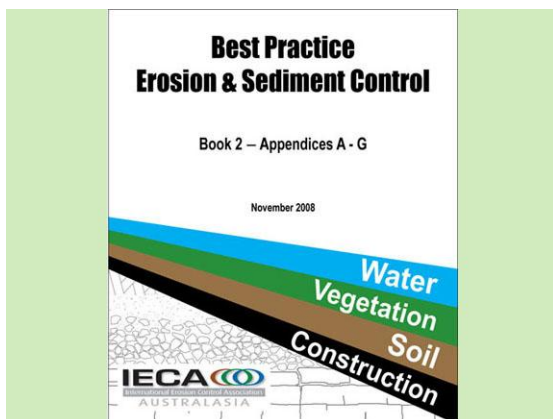


Photo supplied by Catchments & Creeks Pty Ltd

Replacement of telegraph pole



IECA (2008) – Appendix E



IECA (2008) – Appendix F

## Conceptual ESCPs

- Conceptual Erosion and Sediment Control Plans (ESCPs) are prepared when a proposed development is considered to be high risk.
- The final ESCP can be significantly different from the Conceptual ESCP, but the key outcomes must still be achieved.
- The plan (left) presents the Conceptual ESCP for the Case Study site that will be used throughout this and the following chapter.

## Generic ESCPs

- Generic ESCPs present the types of ESC measures that are considered appropriate for regular, low-risk construction and maintenance activities.
- Examples of such work include:
  - replacement of stormwater pits
  - replacement of power/telegraph poles
  - repair of pipe failures
  - road and drainage maintenance.

## Risk assessment

- The 'risk' (or environmental risk, or soil loss hazard) associated with a specific land disturbance is usually assessed in one of two ways (IECA Aust., 2008):
  - Universal Soil Loss Equation (USLE)
  - Erosion Hazard Assessment Form.
- An example Erosion Hazard Assessment Form is provided over the page.
- A simplified alternative to an erosion hazard assessment form is the TASK number.

## TASK number

$$H = T \cdot A \cdot S \cdot K$$

where:

H = Numerical value of the TASK number

T = Duration of soil disturbance [months]

A = Total area of soil disturbance

S = Slope factor (IECA Aust., 2008)

K = Soil erosivity factor (USLE K-factor).

- A high-risk site will have a TASK number that exceeds 200, or some other value specified by the regulator.

**Table 2 – Example Erosion Hazard Assessment Form**

Condition	Points	Score	Trigger value
<b>AVERAGE SLOPE OF DISTURBANCE AREA</b> <ul style="list-style-type: none"> <li>not more than 3% [3% . 33H:1V]</li> <li>more than 3% but not more than 5% [5% = 20H:1V]</li> <li>more than 5% but not more than 10% [10% = 10H:1V]</li> <li>more than 10% but not more than 15% [15% . 6.7H:1V]</li> <li>more than 15%</li> </ul>	0 1 2 4 6		<b>4</b>
<b>SOIL CLASSIFICATION GROUP</b> <ul style="list-style-type: none"> <li>GW, GP, GM, GC</li> <li>SW, SP, OL, OH</li> <li>SM, SC, MH, CH</li> <li>ML, CL, or if <i>imported fill</i> is used, or if soils are untested</li> </ul>	0 1 2 3		
<b>EMERSON (DISPERSION) CLASS NUMBER</b> <ul style="list-style-type: none"> <li>Class 4, 6, 7, or 8</li> <li>Class 5</li> <li>Class 3, (default value if soils are untested)</li> <li>Class 1 or 2</li> </ul>	0 2 4 6		<b>6</b>
<b>DURATION OF SOIL DISTURBANCE</b> <ul style="list-style-type: none"> <li>not more than 1 month</li> <li>more than 1 month but not more than 4 months</li> <li>more than 4 months but not more than 6 months</li> <li>more than 6 months</li> </ul>	0 2 4 6		<b>6</b>
<b>AREA OF DISTURBANCE</b> <ul style="list-style-type: none"> <li>not more than 1000 m<sup>2</sup></li> <li>more than 1000 m<sup>2</sup> but not more than 5000 m<sup>2</sup></li> <li>more than 5000 m<sup>2</sup> but not more than 1 ha</li> <li>more than 1 ha but not more than 4 ha</li> <li>more than 4 ha</li> </ul>	0 1 2 4 6		<b>4</b>
<b>WATERWAY DISTURBANCE</b> <ul style="list-style-type: none"> <li>No disturbance to a watercourse, open drain or channel</li> <li>Involves disturbance to a constructed open drain or channel</li> <li>Involves disturbance to a natural watercourse</li> </ul>	0 1 2		<b>2</b>
<b>REHABILITATION METHOD</b> Percentage of area (relative to total disturbance) revegetated by seeding without light mulching (i.e. worst-case revegetation method). <ul style="list-style-type: none"> <li>not more than 1%</li> <li>more than 1% but not more than 5%</li> <li>more than 5% but not more than 10%</li> <li>more than 10%</li> </ul>	0 1 2 4		
<b>RECEIVING WATERS</b> <ul style="list-style-type: none"> <li>Saline waters only</li> <li>Freshwater body (e.g. creek or freshwater lake or river)</li> </ul>	0 2		
<b>SUBSOIL EXPOSURE</b> <ul style="list-style-type: none"> <li>No subsoil exposure except of service trenches</li> <li>Subsoils are likely to be exposed</li> </ul>	0 2		
<b>EXTERNAL CATCHMENTS</b> <ul style="list-style-type: none"> <li>No external catchment</li> <li>External catchment diverted around the soil disturbance</li> <li>External catchment not diverted around the soil disturbance</li> </ul>	0 1 2		
<b>ROAD CONSTRUCTION</b> <ul style="list-style-type: none"> <li>No road construction</li> <li>Involves road construction works</li> </ul>	0 2		
<b>pH OF SOILS TO BE REVEGETATED</b> <ul style="list-style-type: none"> <li>more than pH 5.5 but less than pH 8</li> <li>other pH values, or if soils are untested</li> </ul>	0 1		
(Conceptual ESCP required for a score of 17 or greater) <b>Total score =</b>			

## Conceptual Erosion and Sediment Control Plans



Small development site



Large development site



Large development site



Soil testing

### Low-risk sites

- There is no standard way for regulators to manage high-risk and low-risk sites.
- Typically (in the author's opinion) if the site has been assessed as **low-risk**, then:
  - the project can move onto the detail design phase without further discussion on ESC issues at the planning phase
  - when the final ESCP is submitted for approval, the plan will likely be reviewed by a general development assessment officer.

### High-risk sites (planning phase)

- If a site has been assessed as high-risk during the **planning phase** (i.e. during land rezoning, or preliminary design approval), then:
  - a Conceptual ESCP should be requested
  - the Conceptual ESCP should be prepared by an ESC specialist
  - the developer may be asked to demonstrate that there is a feasible means of constructing the project.

### High-risk sites (detail design phase)

- If a site has been assessed as high-risk during the **detailed design phase** (i.e. at the stage of final plan approval), then:
  - the proposed ESCP should be prepared by an ESC specialist reviewed by a CPESC member.
- Risk assessments are normally carried out at **both** the planning and design stages because the site's risk can change significantly from the planning phase to the final design.

### Purpose of Conceptual ESCPs

The purpose of a Conceptual ESCP is to:

- Ensure appropriate soil data is collected, and site constraints are identified.
- Ensure key ESC issues are discussed during the planning phase.
- Allow regulatory authorities to voice their concerns before a development proposal progresses too far.
- Allow the developer to demonstrate that there is a feasible means of constructing the project without causing harm.

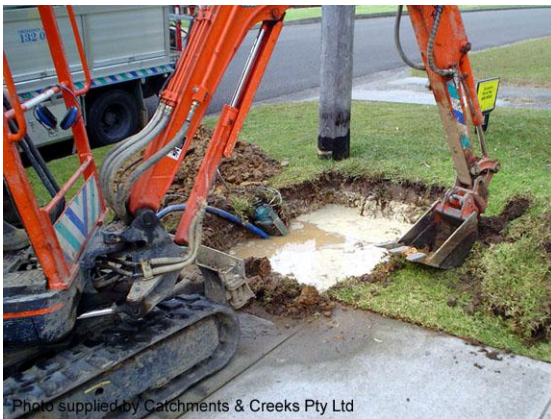
## Generic Erosion and Sediment Control Plans



**Private driveway crossing of a creek**

### Construction of minor waterway crossings

- Most maintenance and construction activities that are conducted within a waterway must be approved, and regulated, by some level of government.
- However, it is not an efficient use of public funds for governments to review **every** work activity; consequently, **some** authorities prepare **Deemed To Comply** instructions and associated ESC Plans that can be used for those works they deem to be minor work activities.



**Emergency repair to broken pipeline**

### Minor works conducted by utility providers

- Generic ESC Plans could be developed for work activities such as:
  - replacement of telegraph poles
  - connection of new homes to water and sewerage
  - repair of pressure pipe failures
  - replacement of pipe valves
  - construction of small service buildings
  - minor pipe crossings of waterways
  - trenching new cables.



**Replacement of roadside stormwater pit**

### Council drainage works

- Generic ESC Plans could be developed for work activities such as:
  - replacement of stormwater pits
  - connection of new homes to services
  - construction of traffic-calming islands
  - construction of pedestrian crossings
  - installation of traffic barriers
  - replacement of roadside kerb and channel.



**De-silting of a stormwater drain**

### Regular maintenance work in waterways

- Generic ESC Plans could be developed for work activities such as:
  - de-silting storm drains
  - weeding storm drains
  - post-flood silt and debris removal from waterway crossings
  - post-flood creek bank repairs
  - construction of footbridges, ford crossings and minor culverts
  - removal of woody weeds from riparian zones.

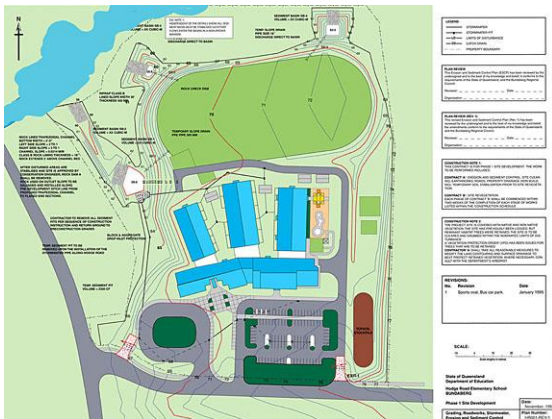
## Hodge Road Elementary School, Knightdale, North Carolina, USA



Hodge Road Elementary School, NC

### The real site

- Hodge Road Elementary School is located off Mingo Bluff Boulevard in Knightdale, Wade County, North Carolina, USA.
- Hodge Road passes down the western side of the school.
- The author visited the construction site on 6<sup>th</sup> April, 1995 with an officer from the North Carolina Department of Natural Resources and Community Development.
- The original ESCP (shown on the cover) was prepared for the site in 1994.



Adopted site conditions

### The use of Hodge Road as a Case Study

- The Case Study may be based on a real site, but all the support documentation presented within the Case Study has been **invented** by the author for the purpose of preparing this training document.
- Consequently, the following plans do **not** represent the actual site conditions observed in Wade County, NC.
- In developing an ESCP for this site, the author has tried to mimic, but not copy, those measures **adopted** on the actual school site.



Figure 1 – Hodge Road Elementary School, Wade County, North Carolina (Google image)

# Case Study – Hodge Road Elementary School Conceptual ESCP

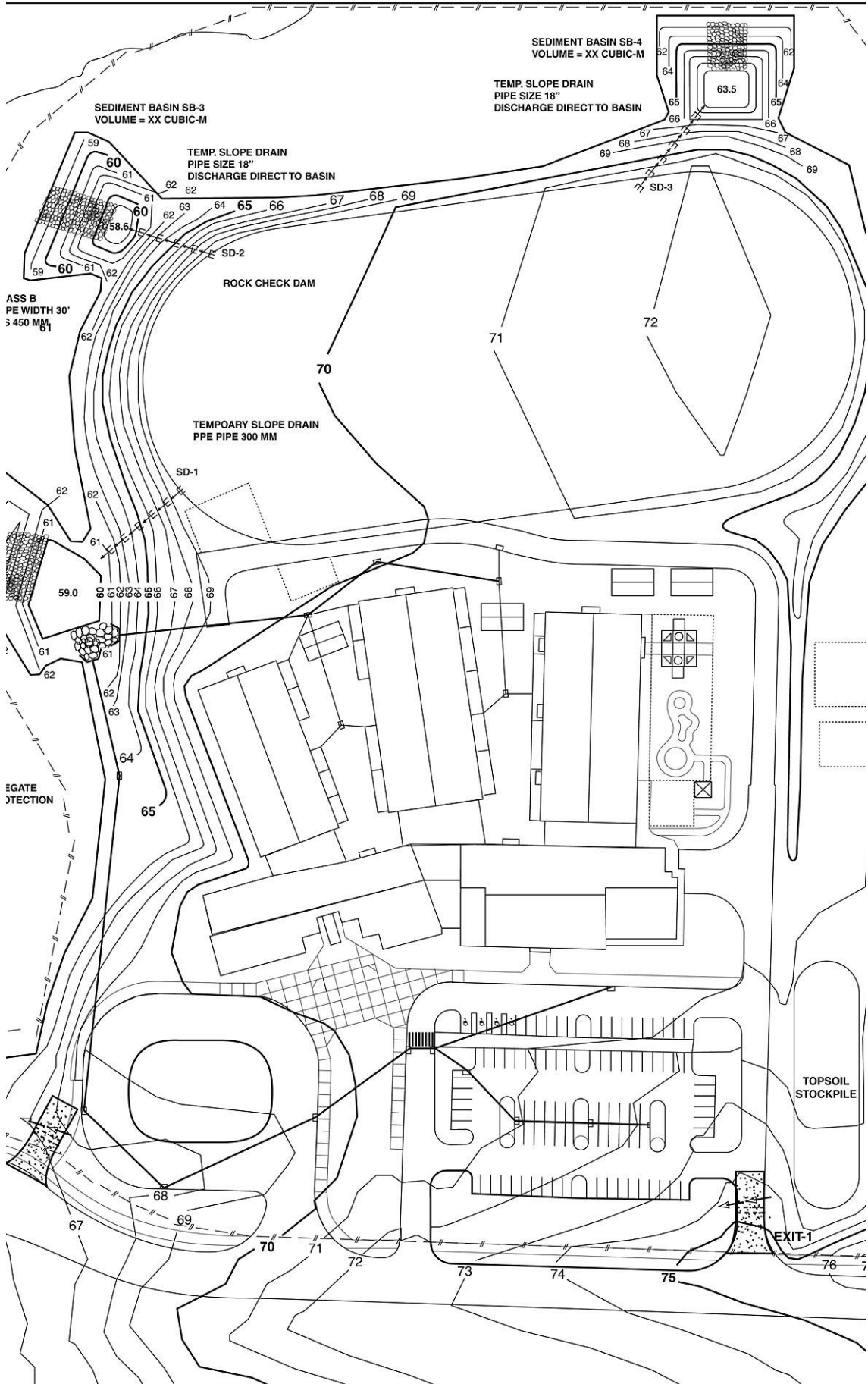


Figure 2 – Conceptual Erosion and Sediment Control Plan

**Hodge Road Elementary School, Knightdale, North Carolina, USA**



**School entrance (2022)**



**Western entrance (pick-up / drop-off circuit)**



**Entrance to car park**



**Eastern entrance with school bus parking on right**

**Table 3 – Hodge Road School Erosion Hazard Assessment Form**

Condition	Points	Score	Trigger value
<b>AVERAGE SLOPE OF DISTURBANCE AREA</b> <ul style="list-style-type: none"> <li>not more than 3% [3% . 33H:1V] 0</li> <li><b>more than 3% but not more than 5% [5% = 20H:1V] 1</b></li> <li>more than 5% but not more than 10% [10% = 10H:1V] 2</li> <li>more than 10% but not more than 15% [15% . 6.7H:1V] 4</li> <li>more than 15% 6</li> </ul>		1	4
<b>SOIL CLASSIFICATION GROUP</b> <ul style="list-style-type: none"> <li>GW, GP, GM, GC 0</li> <li>SW, SP, OL, OH 1</li> <li>SM, SC, MH, CH 2</li> <li><b>ML, CL, or if imported fill is used, or if soils are untested 3</b></li> </ul>		3	
<b>EMERSON (DISPERSION) CLASS NUMBER</b> <ul style="list-style-type: none"> <li>Class 4, 6, 7, or 8 0</li> <li>Class 5 2</li> <li><b>Class 3, (default value if soils are untested) 4</b></li> <li>Class 1 or 2 6</li> </ul>		4	6
<b>DURATION OF SOIL DISTURBANCE</b> <ul style="list-style-type: none"> <li>not more than 1 month 0</li> <li>more than 1 month but not more than 4 months 2</li> <li><b>more than 4 months but not more than 6 months 4</b></li> <li>more than 6 months 6</li> </ul>		4	6
<b>AREA OF DISTURBANCE</b> <ul style="list-style-type: none"> <li>not more than 1000 m<sup>2</sup> 0</li> <li>more than 1000 m<sup>2</sup> but not more than 5000 m<sup>2</sup> 1</li> <li>more than 5000 m<sup>2</sup> but not more than 1 ha 2</li> <li><b>more than 1 ha but not more than 4 ha (approximately 2.5 ha) 4</b></li> <li>more than 4 ha 6</li> </ul>		4	4
<b>WATERWAY DISTURBANCE</b> <ul style="list-style-type: none"> <li><b>No disturbance to a watercourse, open drain or channel 0</b></li> <li>Involves disturbance to a constructed open drain or channel 1</li> <li>Involves disturbance to a natural watercourse 2</li> </ul>		0	2
<b>REHABILITATION METHOD</b> Percentage of area (relative to total disturbance) revegetated by seeding without light mulching (i.e. worst-case revegetation method). <ul style="list-style-type: none"> <li><b>not more than 1% 0</b></li> <li>more than 1% but not more than 5% 1</li> <li>more than 5% but not more than 10% 2</li> <li>more than 10% 4</li> </ul>		0	
<b>RECEIVING WATERS</b> <ul style="list-style-type: none"> <li>Saline waters only 0</li> <li><b>Freshwater body (e.g. creek or freshwater lake or river) 2</b></li> </ul>		2	
<b>SUBSOIL EXPOSURE</b> <ul style="list-style-type: none"> <li>No subsoil exposure except of service trenches 0</li> <li><b>Subsoils are likely to be exposed 2</b></li> </ul>		2	
<b>EXTERNAL CATCHMENTS</b> <ul style="list-style-type: none"> <li><b>No external catchment 0</b></li> <li>External catchment diverted around the soil disturbance 1</li> <li>External catchment not diverted around the soil disturbance 2</li> </ul>		0	
<b>ROAD CONSTRUCTION</b> <ul style="list-style-type: none"> <li>No road construction 0</li> <li><b>Involves road construction works 2</b></li> </ul>		2	
<b>pH OF SOILS TO BE REVEGETATED</b> <ul style="list-style-type: none"> <li><b>more than pH 5.5 but less than pH 8 0</b></li> <li>other pH values, or if soils are untested 1</li> </ul>		0	
(Conceptual ESCP required for a score of 17 or greater) <b>Total score =</b>		<b>22</b>	<b>Triggered</b>

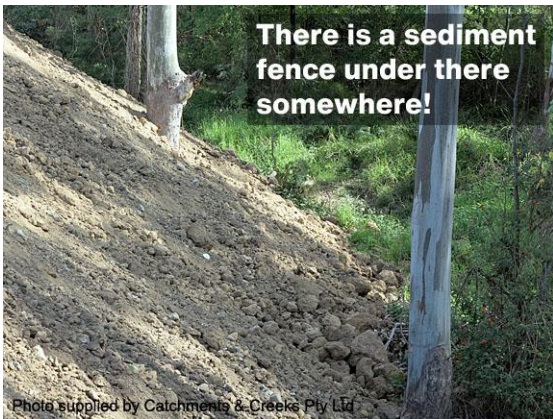
## Case Study – Hodge Road School (fictitious site conditions)



Potential site clearing

### Erosion Hazard Assessment Form

- The completed Erosion Hazard Assessment Form of the Case Study site is presented in Table 3.
- A total score of 22 was achieved for the original school layout, which incorporated a full-sized sports oval.
- A score greater than 17 would trigger this site as high risk.
- It is noted that the total area of soil disturbance, which approximates 2.5 ha, also triggers the site as high risk.



Buried trees and sediment fence

### Identified environmental concerns

- During planning negotiations between the Department of Education and the council, the following concerns were raised:
  - the proximity of the proposed sediment basins to the Mingo Creek, and
  - the sports oval batter that would extend up to the edge of the riparian zone.
- The photos shown left and below demonstrate the potential problems of constructing an earth batter adjacent to bushland ([unrelated construction site](#)).



Figure 3 – The problem of filling up to the edge of a ‘protected’ riparian zone

## Case Study – Hodge Road School (fictitious site conditions)



Revised sports oval design

### Revised school layout

- Given the concerns raised about the potential harm to Mingo Creek, and the risks to the highly-valued [Mingo Creek Trail](#), it was decided that a smaller sports oval would be constructed.
- The council was able to negotiate with the adjacent subdivision, which was also passing through the planning phase, to have their 10% open space contribution developed as a sports oval that could be use (leased) by the school.



Revised location of sediment basins

### Revised ESCP

- A new ESC Plan was prepared for the revised school layout.
- This revised plan could have been a Conceptual Plan prepared during the planning phase, or a construction plan developed during the design phase.
- The following chapter discusses, step by step, how such a plan could be developed.
- Readers should note that there is no single plan for such a site, and there is also no universally adopted method for developing an ESCP.

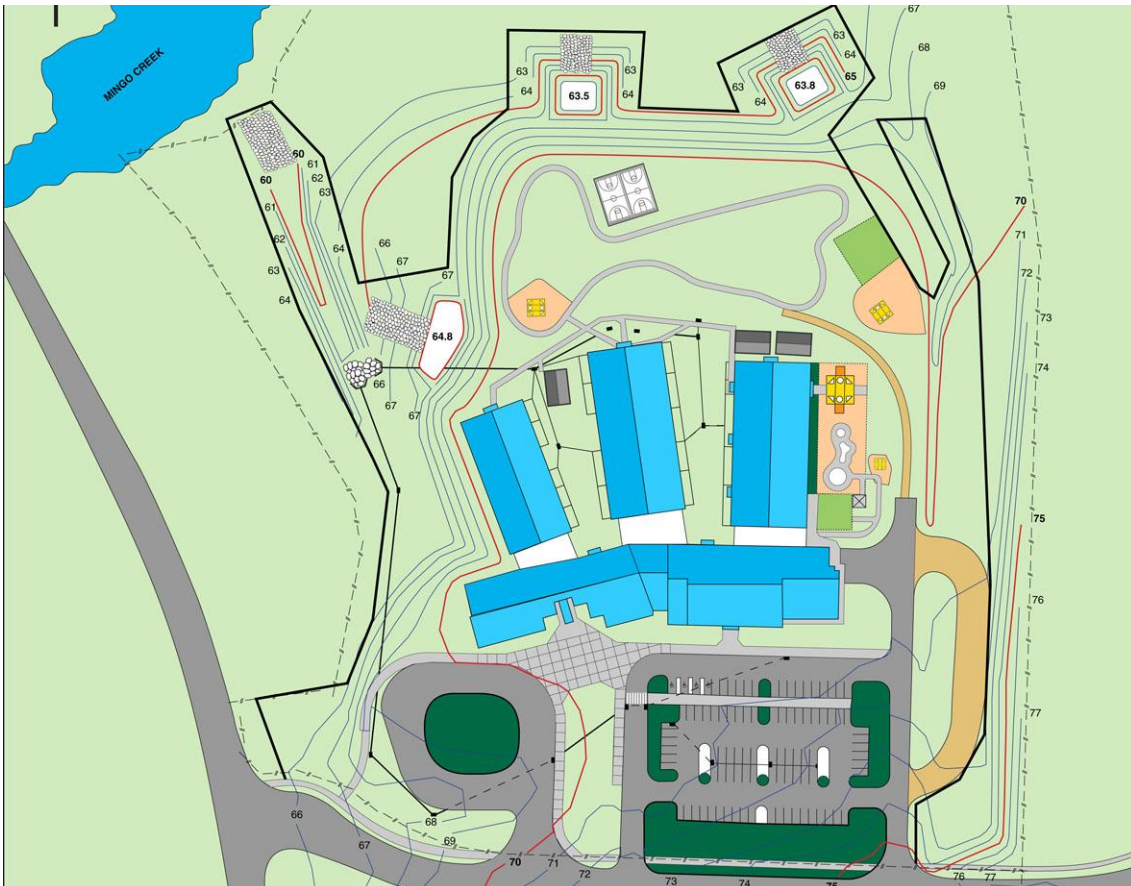


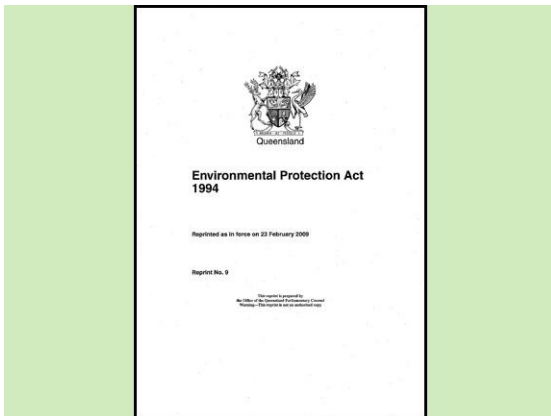
Figure 4 – Revised layout of the sports oval (not the final ESCP)

## **2. Preparation of Erosion and Sediment Control Plans**

## Introduction



Design office



Environmental legislation



Complex construction site (NSW)



Photo supplied by Catchments & Creeks Pty Ltd

Common sense gone missing!

## Introduction

- This chapter provides **just one possible procedure** for the preparation of Erosion and Sediment Control Plans.
- Not all of these design steps will be relevant on each site.
- Strict adherence to the order of design steps is not essential.

## Local rules and regulations

- This document is presented as a general guide.
- ESC designers should always be familiar with the **local** rules and regulations.
- ESC Plans must consider all relevant local, state and federal legislation, and industry codes of practice (if available).

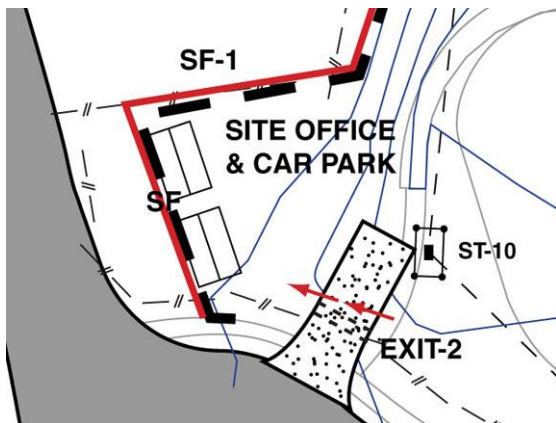
## The staging of earthworks

- The following procedure for the development of Erosion and Sediment Control Plans is based on:
  - a separate ESCP being developed for each stage of earthworks
  - the same procedure adopted each time a new plan is developed.
- It may seem logical to develop an ESCP in-line with the construction sequence; however, such an approach usually results in an excessive reliance on sediment control measures.

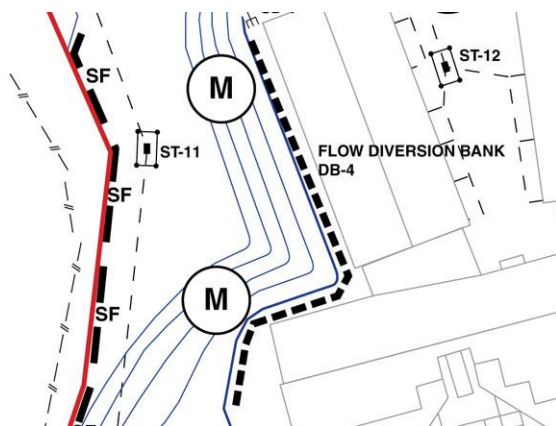
## A 'common sense' approach

- Erosion and sediment control practices are said to be at **'the cutting edge of common sense'**.
- Wherever possible, common sense must rule over **generic** solutions that are not tailored to the actual site conditions.
- No rule or recommendation should be allowed to overrule the application of a **site specific solution** that can be demonstrated to satisfy the principle objective of minimising environmental harm.

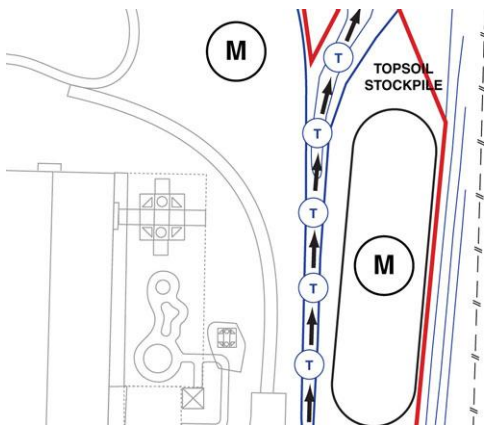
## Possible contents of an ESCP



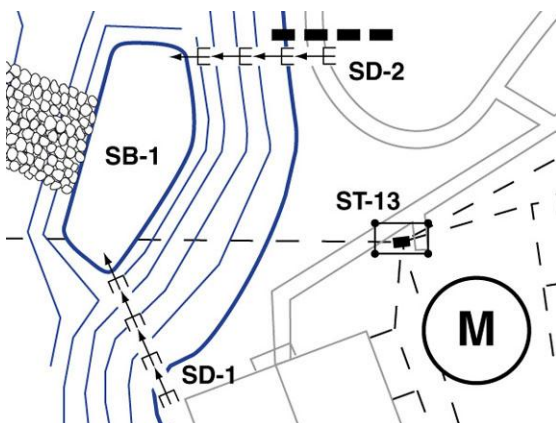
Site office



Drainage control measures



Erosion control measures



Sediment control measures

The type of information that is likely to be included on an Erosion and Sediment Control Plan includes:

- North point and plan scale.
- Site and easement boundaries.
- Construction access points.
- Site office, car park and stockpiles.
- Limits of disturbance.
- Retained / protected vegetation.
- Location of problem soils.
- Location of critical environmental values.
- Existing and final land contours.
- Construction Drainage Plans for each stage of earthworks (as an attachment).
- Staging of earthworks.
- Drainage, erosion and sediment control measures.
- Full design and construction details (e.g. cross-sections, minimum channel grades, channel linings,) for all drainage and sediment control devices, including Diversion Channels and Sediment Basins (as an attachment).
- Construction specifications for adopted ESC measures (as an attachment).
- Standard drawings of ESC measures (as an attachment).
- Site revegetation requirements (if not contained within separate plans).
- Site Monitoring and Maintenance Program (as an attachment).
- Technical notes, most commonly associated with:
  - erosion control measures required prior to site revegetation
  - specifications for temporary grass seeding
  - preparing the site for a storm
  - preparing the site for a site shutdown (e.g. Christmas shutdown)
  - protection of excavations and trenches if storms are expected overnight.
- Calculation sheets for the sizing of ESC measures (as an attachment).
- A completed Erosion and Sediment Control Plan checklist (as an attachment).

# Development of plans that can adapt to changing seasons



## Development of ESC Plans

### Example technical notes

This Section provides example technical notes for use on Erosion and Sediment Control Plans (ESCPs). Not all of the following notes will be applicable to each site. The following example technical notes may be modified as necessary to ensure applicability to a given site or construction activity.

It is the designer's responsibility to ensure that all technical notes incorporated into an ESCP are appropriate and any specified operational requirements, such as those specified within the development approval conditions.

#### General

1. Additional erosion and sediment control measures must be implemented and a revised Erosion and Sediment Control Plan (ESCP) must be submitted for approval in the event that site conditions change significantly from those outlined within the ESCP.
2. Additional erosion and sediment control measures must be implemented and a revised Erosion and Sediment Control Plan (ESCP) must be submitted for approval in the event that the requirements set out in the State "Register" of the ESCP, the local government ESC standard, or the State's environmental protection requirements (where applicable) change.
3. Where there is a high probability that serious or material environmental harm may occur as a result of implementing the site-specific additional erosion and sediment control measures, the ESCP must be amended to include all necessary and practicable measures to prevent or minimise such harm. Only those measures necessary to minimise or prevent environmental harm shall be considered on-site prior to approval of the amended Erosion and Sediment Control Plan (ESCP).
4. Where there is a high probability that serious or material environmental harm may occur as a result of implementing the site-specific additional erosion and sediment control measures, the ESCP must be amended to include all necessary and practicable measures to prevent or minimise such harm. Only those measures necessary to minimise or prevent environmental harm shall be considered on-site prior to approval of the amended ESCP (where applicable).

5. In circumstances where it is considered necessary to prepare an amended Erosion and Sediment Control Plan (ESCP), and where the delivery of such an amended ESCP or other measures to prevent or minimise such harm, upon approval of the amended ESCP, it shall be implemented in accordance with the amended plan.
6. Land clearing must be delayed as long as practicable and must be undertaken in conjunction with development of each stage overhead, unless otherwise approved (where applicable).
7. All reasonable and practicable efforts must be taken to delay the removal of, or disturbance to, existing ground cover (organic or inorganic) prior to land disturbing activities.
8. Bulk-tine clearing must occur in a manner that minimises disturbance to existing ground cover (organic or inorganic).

9. Bulk-tine clearing and grubbing of the site must be immediately followed by specified temporary stabilisation measures (e.g. temporary seeding, mulching) prior to commencement of each stage of construction.
10. Disturbance to natural environment (including bed and banks) and their associated riparian zones must be limited to the minimum practicable.
11. No land clearing shall be undertaken unless provided by the installation of adequate drainage and sediment control measures, unless such clearing is required for the purpose of installing such measures, in which case, only the minimum clearing required to install such measures shall occur.
12. Land clearing must be limited to 5m from the edge of proposed constructed works, 2m of essential construction traffic routes, and a total of 10m width for construction access, unless otherwise approved by the responsible authority.
13. Prior to land clearing, areas of protected vegetation, and significant areas of retained vegetation must be clearly identified (e.g. with high-visibility signs, or light fencing) for the purposes of minimising the risk of unnecessary land clearing.
14. All reasonable and practicable measures must be taken to minimise the removal of, or disturbance to, trees, shrubs and ground cover (organic or inorganic) that are considered to be retained.
15. All land clearing must be in accordance with the Federal, State and local government best practice "Protective" preservation requirements and/or policies.
16. Land clearing is limited to the minimum practicable during those periods when the erosion and sediment control measures are not in place.
17. Land clearing must not extend beyond that necessary to provide up to eight (8) metres of site access during those months when the proposed works activity is limited to 100 to 200 mm of rain (or 100 and 200 mm of rain, as applicable, and 1000 and 2000 mm of rain, as applicable).
18. Land clearing must not extend beyond that necessary to provide up to eight (8) metres of site access during those months when the daily or average rainfall is less than 50mm, and/or between 50 and 100mm, and/or between 100 and 200mm, and less than 20mm, if greater than 20mm, (whichever is applicable).

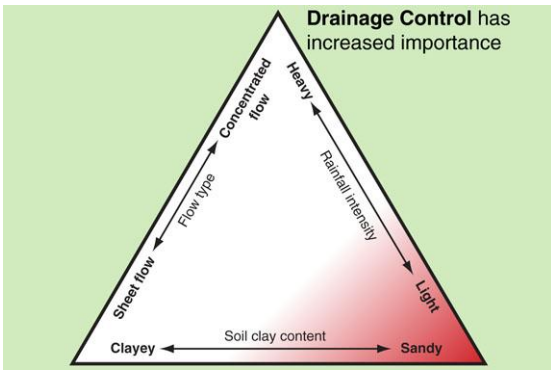
## Introduction

- In many cases the actual time of year the construction works commence will not be known at the time the Erosion and Sediment Control Plan is prepared.
- This means that the ESCP **may** need to be adaptive to both periods of extended dry weather, and periods of wet weather.
- **Technical notes** can be attached to a Plan to identify specific actions that will be required during certain weather conditions.

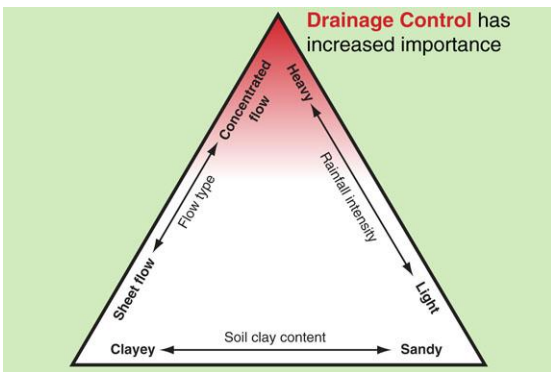
## Technical notes

- Standard technical notes can be developed for different climatic regions.
- These notes provide information on what ESC measures must be operational during certain months of the year.
- In Australia it can be **assumed** that:
  - north of Sydney there is going to be a wet and dry season
  - the Sydney latitude will have a near uniform rainfall risk throughout the year
  - south of Sydney, heavy rainfall will dominate the winter months.

## Technical notes



**A dry weather focus**



**A wet weather focus**

## A dry weather focus

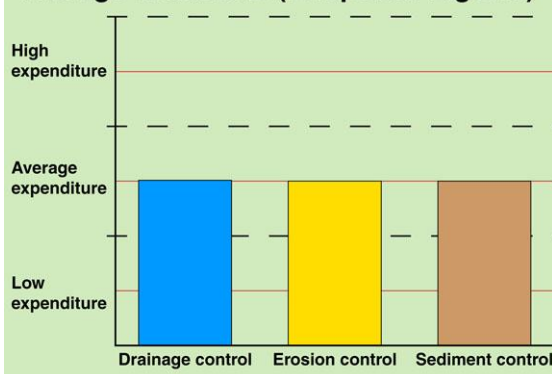
- During periods of extended dry weather, the ESCP should focus on:
  - sediment controls at site exit points
  - dust control
  - surface roughening, mulching, or the dry-seeding of finished soil surfaces
  - functional Type-3 sediment traps
  - establishment of an annual grass over finished soil surfaces, which can be allowed to die-off after 70% coverage of the soil is achieved.

## A wet weather focus

- During periods of extended wet weather, the ESCP should focus on:
  - ensuring all ESC measures remain operational
  - ensuring site drainage controls prevent damage to erosion and sediment control measures
  - separation of vehicle movement from the flow path of stormwater runoff
  - functional Type-1 & 2 sediment traps
  - control of raindrop impact erosion.

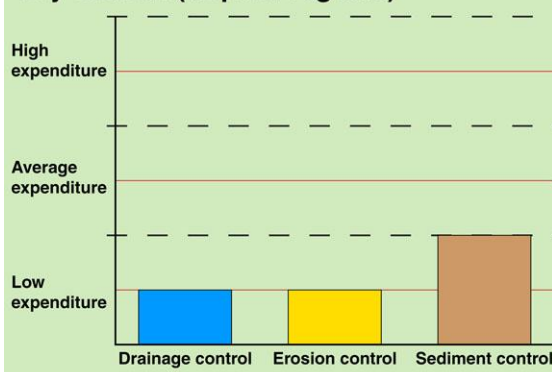
## Balancing drainage, erosion, and sediment controls

### Average conditions (Temperate regions)



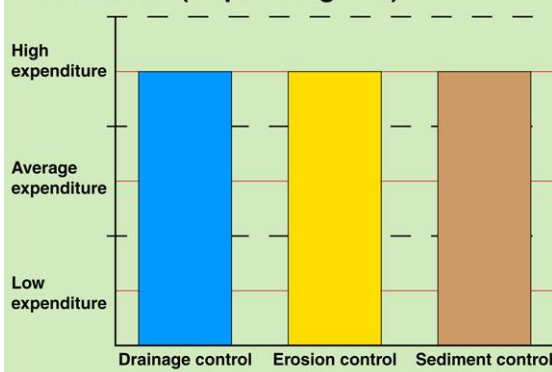
Average site conditions

### Dry Season (tropical regions)



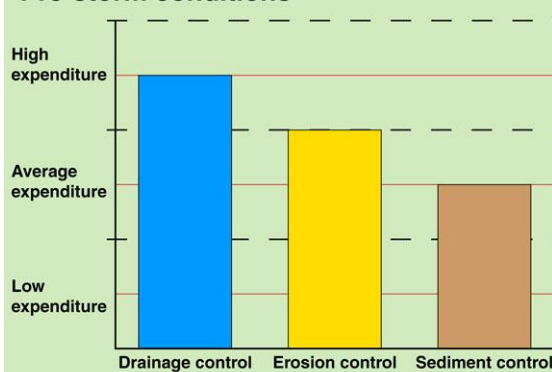
Dry season expenditure

### Wet Season (tropical regions)



Wet season expenditure

### Pre-storm conditions



Pre-storm maintenance

### Introduction

- The following examples demonstrate how drainage, erosion and sediment controls can vary in their intensity (or design standard) as weather conditions change.
- The term 'drainage control' refers only to the temporary drainage control measures that are required to be operational prior to construction of the permanent stormwater drainage system.
- The vertical axis is relative to the average expenditure for each of the three types of controls.

### Dry season ESC measures

- Not all regions experience well-defined wet and dry seasons.
- The application of Environmental Best Management Practice (EBMP) does not imply maximum control at all times, irrespective of the cost.
- Environmental Best Management Practice requires consideration of ESC practices that are applied both regionally, nationally and internationally, which means avoiding unnecessary expenditure if a potential environmental risk is not present.

### Wet season ESC measures

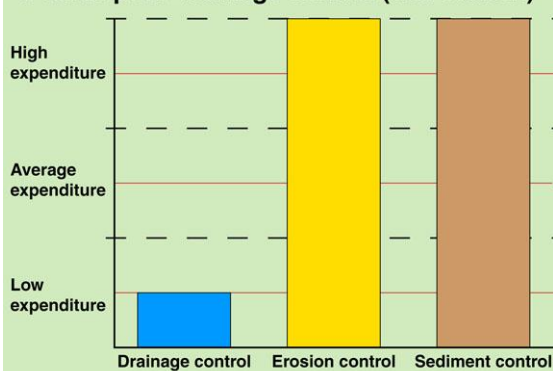
- It is a natural human response for construction personnel to focus on installing more sediment controls (e.g. sediment fences) if the existing sediment controls are being damaged by storms.
- However, the appropriate response by construction personnel should be to focus on fixing the drainage problems that are causing the sediment controls to be damaged or overloaded.
- Expenditure on all three control categories must increase during the wet season.

### Expenditure prior to an imminent storm

- If a storm is imminent, then the ESC measures should focus on:
  - maintenance of drainage controls
  - connection of finished sections of the permanent drainage system if the drainage area is clean, or the drainage system is connected to a sediment trap
  - turfing, not seeding
  - anchorage of erosion control blankets against strong winds
  - cover finished earthworks with topsoil.

## Balancing drainage, erosion, and sediment controls

### Cost of poor drainage control (wet season)

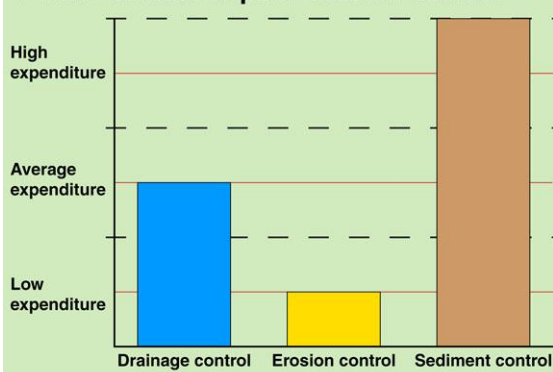


### Consequence of poor drainage control

### The cost of not having appropriate drainage controls

- If a construction site focused solely on erosion and sediment control measures, and not on temporary drainage control, then the likely outcomes would be:
  - increased expenditure on erosion control measures because the uncontrolled stormwater runoff would wash away mulch, seed, and blankets
  - increased expenditure on sediment control measures to de-silt and constantly repair sediment traps.

### Financial cost of poor erosion control

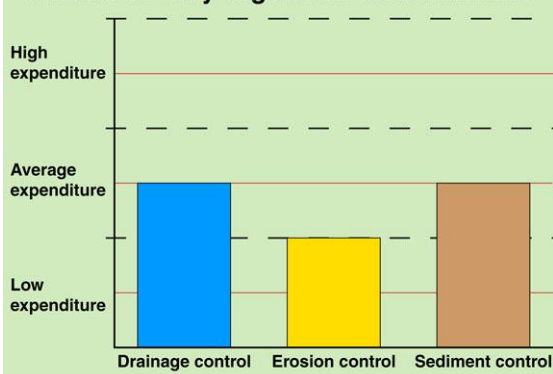


### Consequence of poor erosion control

### The cost of not having appropriate erosion controls

- If a construction site failed to apply adequate erosion control measures (because they believe such measures are attached to the revegetation contract), then the likely outcomes would be:
  - a significant increase in the expenditure on sediment control measures in order to meet the legislated coarse sediment and turbidity concentration limits placed on stormwater runoff.

### Benefits of early vegetation establishment

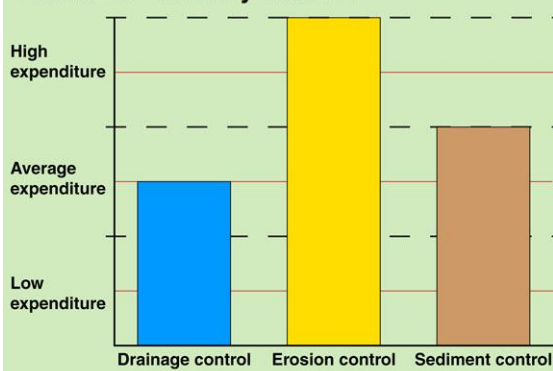


### Benefits of early site revegetation

### Financial benefit of early site revegetation

- If a construction site actively encouraged, and facilitated the early implementation of the site's landscape plan, then the likely outcomes would be:
  - reduced need for temporary erosion control measures
  - reduced expenditure on erosion control measures.
- Note: On some sites, the earthworks contractor will have no control over the timing of site revegetation.

### Focus on turbidity control

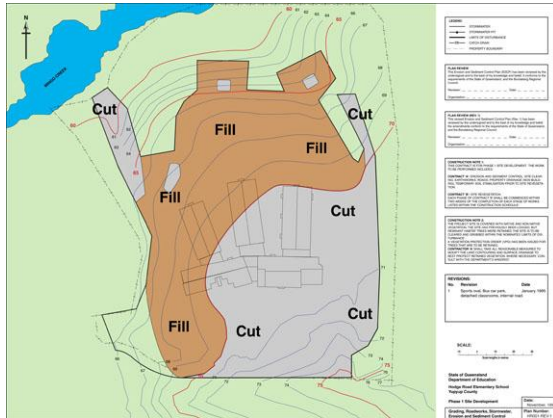


### Management of runoff turbidity

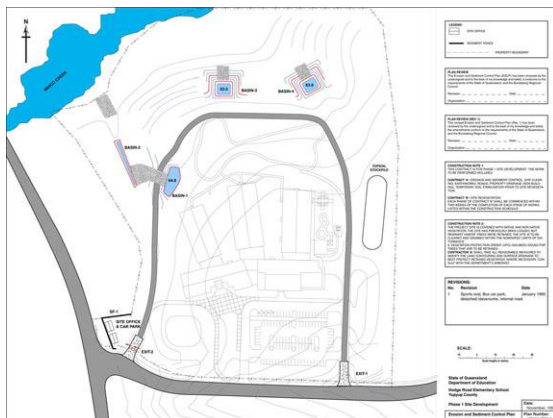
### Applying measures to control runoff turbidity

- Turbidity controls include:
  - minimising the duration of soil exposure
  - covering disturbed soils
  - Type A and B sediment basins.
- If, while reviewing each of the above bar graphs, you believed that there should never be a reduction in the expenditure on sediment control, then you are likely to be a person that pushes the industry towards a focus that is just on 'sediment control'.

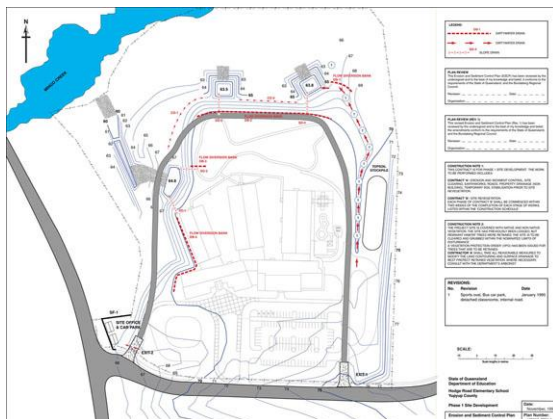
## Suggested steps in the development of an ESCP



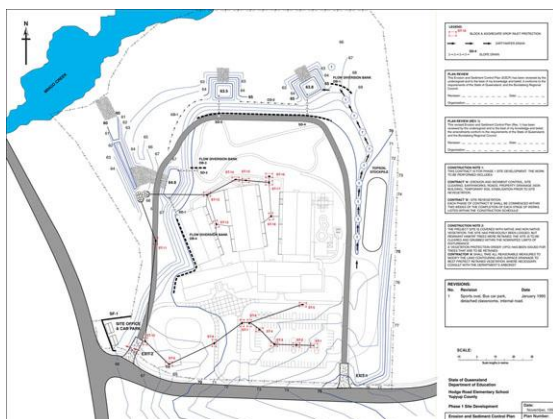
**Cut and fill plan**



**Placement of sediment basins**



**Placement of dirty water drainage**



**Placement of stormwater inlet traps**

## Suggested steps in the development of an Erosion and Sediment Control Plan

- Step 1 - Review local issues, concerns and site constraints
- Step 2 - Review the development layout
- Step 3 - Review soil data
- Step 4 - Prepare a cut and fill plan
- Step 5 - Prepare a Construction Drainage Plan
- Step 6 - Locate traffic entry/exit points and associated ESC measures
- Step 7 - Locate and protect the site office and stockpile areas
- Step 8 - Identify potential areas of non-disturbance
- Step 9 - Review access roads and temporary watercourse crossings
- Step 10 - Determine the required sediment control standard
- Step 11 - Locate major sediment traps
- Step 12 - Review proposed staging of works
- Step 13 - Control 'clean' water run-on and runoff
- Step 14 - Control erosion within all drains
- Step 15 - Control 'dirty' water runoff
- Step 16 - Control soil erosion on all disturbed areas
- Step 17 - Establish sediment traps within the development
- Step 18 - Control sediment runoff at property boundary
- Step 19 - Define the final limits of disturbance
- Step 20 - Prepare the site revegetation/rehabilitation plan
- Step 21 - Prepare the installation sequence
- Step 22 - Specify emergency ESC measures
- Step 23 - Prepare the Monitoring and Maintenance Program
- Step 24 - Prepare Inspection and Test Plans
- Step 25 - Supporting documentation

## Case Study – Hodge Road Elementary School background information



Photo supplied by Catchments & Creeks Pty Ltd

### Construction plans

#### Issued contracts (fictitious)

- The **assumed** construction contracts are:
  - School design and ESCP prepared by a design team working for the **Queensland Board of Education**.
  - Land clearing, earthworks, ESC, roads and drainage contract issued to **Tonka Tuff Pty. Ltd.**
  - Building fabrication contract issued to **Schools For Kids Pty. Ltd.**
  - Site revegetation contract issued to **Trees For Wildlife Pty. Ltd.**



### Mingo Bluff Boulevard

#### Existing site conditions

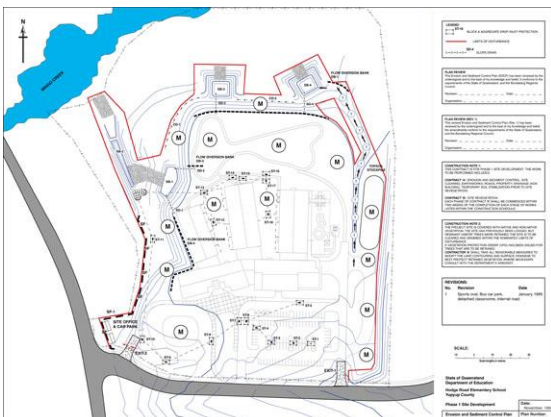
- On the original North Carolina site, Mingo Bluff Boulevard (the road south of the school) did not exist prior to the school's construction, which meant the site only had access from Hodge Road.
- Back in 1995, construction of the school included construction of that portion of Mingo Bluff Boulevard located in front of the school.
- **Case Study: It will be assumed that Mingo Bluff Boulevard already exists.**



### Framing of school building (1995)

#### Fabrication

- Fabrication of the school buildings commenced prior to the completion of the earthworks and complete site stabilisation.



### Case Study final ESCP (see page 112)

#### Hodge Road Case Study

- The final Erosion and Sediment Control Plan developed in this Case Study:
  - does not represent what the author would have prepared in 2023 if given a 'free hand'
  - does mimic the ESC measures adopted in real life on the 1995, North Carolina construction site
  - does represent typical 1995 ESC practices (but not 2023 ESC practices); however, the lessons gained from the Case Study are still the same.

**Case Study – Hodge Road Elementary School (the actual school site)**



**Figure 5 – Revised school layout based on planning approval (Google image)**

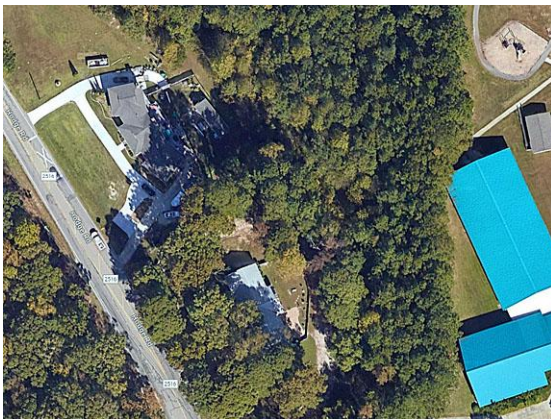
## Step 1 – Review local issues, concerns and site constraints



Mingo Creek

### Site issues and concerns

- Identify the key issues and concerns for the construction site, possibly relating to:
  - site topography, soils and vegetation
  - local environmental values, including fauna and flora, endangered species, waterway values, buffer zones, etc.
  - environmental risks identified within the site's planning reports.
- **Case Study:** Key assets are the protection of Mingo Creek, and the Mingo Creek Trail.



Down-slope properties

### Understand the relative importance of coarse and fine sediments

- Identify the relative importance of minimising the runoff of:
  - coarse sediments (sands and silts)
  - fine sediment (clays and turbidity)
  - wind-blown dust.
- **Case Study site:** Mingo Creek is known to be in a non-pristine (turbid) condition, but turbidity control has been identified as a key objective within the overall waterway catchment to prevent further degradation.

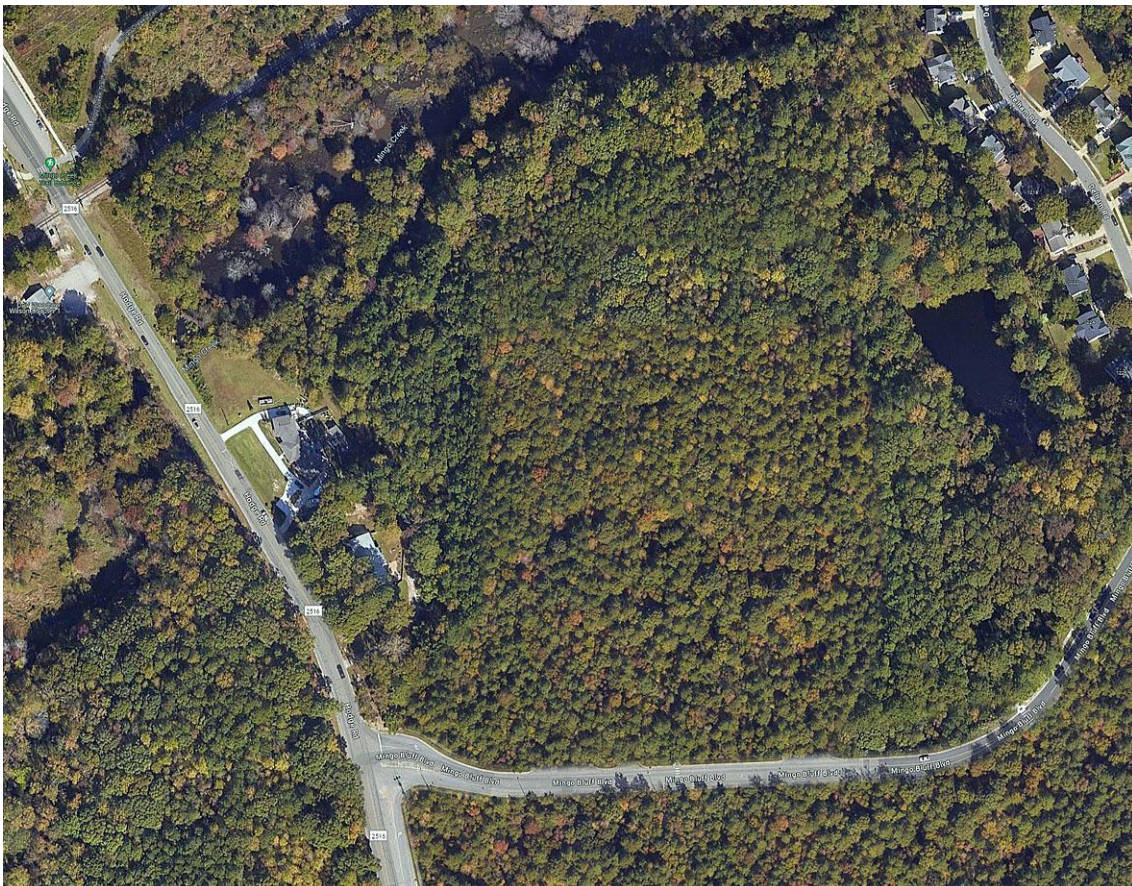
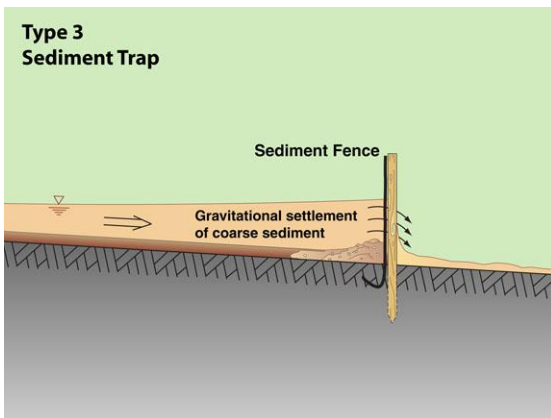


Figure 6 – Site conditions prior to land clearing for the Hodge Road school site

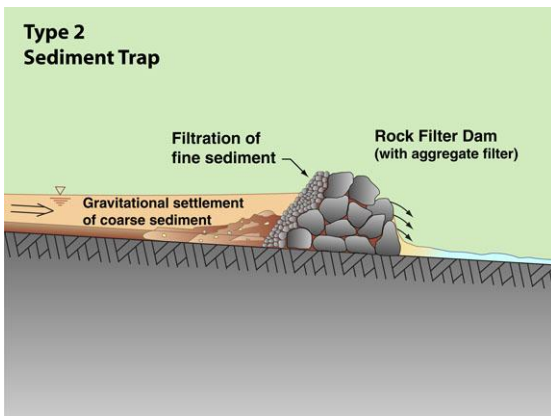
## Controlling the release of sand, silt, clay and turbidity



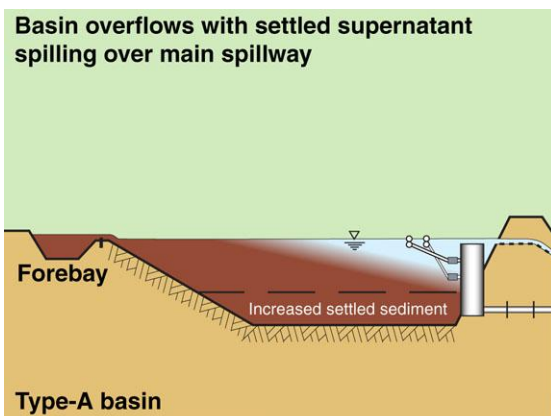
Settled clay, silt and sand



Hydraulic operation of a sediment fence



Rock filter dam with aggregate filter



Type A sediment basin

### Introduction

- Environmental protection requires:
  - looking up-slope, throughout the construction site, to see what types of pollutants are likely to be released from the work site
  - looking down-slope (or downstream) to develop an understanding of the environmental risk different pollutants may have on downstream habitats.
- On construction sites, the key pollutants are sand, silt, clay, turbidity and cement.

### Techniques for capturing 'sand'

- ESC measures that are effective at capturing sand-sized particles include:
  - Type 1, 2 & 3 sediment traps
  - any type of sediment basin
  - any sediment trap that encourages water to pool up-slope of the trap
  - sediment trenches
  - a sediment fence that is installed along a land contour (i.e. along a line of constant elevation).

### Techniques for capturing 'silt'

- ESC measures that are effective at capturing silt-sized particles include:
  - Type 1 & 2 sediment traps
  - any type of sediment basin
  - any sediment trap that encourages sediment-laden water to pass through an aggregate or geotextile filter
  - filter tubes
  - low-velocity sheet flow passing over a grassed filter bed.

### Techniques for minimising the release of 'clay, and/or capturing clay-sized particles'

- ESC measures that are effective at capturing clay-sized particles include:
  - Type 1 sediment traps
  - Type A, B & D sediment basins
  - any sediment trap that encourages sediment-laden water to pass through an earth filter
  - low-velocity sheet flow passing over unsaturated, porous soil.

## Step 2 – Review the development layout



Design office



Discussing design changes

### Look for avoidable construction issues

- This may appear to be an unrealistic step in the construction process—after all, how often does an Erosion and Sediment Control professional get to tell a design team that they should change the layout of the development?
- However, if we consider our Case Study, the design of the school, and the drafting of the Erosion and Sediment Control Plan (ESCP) were both prepared by a design team working directly for the Department of Education.
- One of the most important requirements of any ‘design’ is that it must be possible to build the proposed structure.
- The aim of this step is to identify any aspects of the civil design that may:
  - be impossible to build without causing unnecessary environmental harm
  - result in excessive expenditure on ESC measures in order to achieve the required ESC outcomes
  - or may be easy to redesigned, or relocated, in order to significantly lower the construction costs.

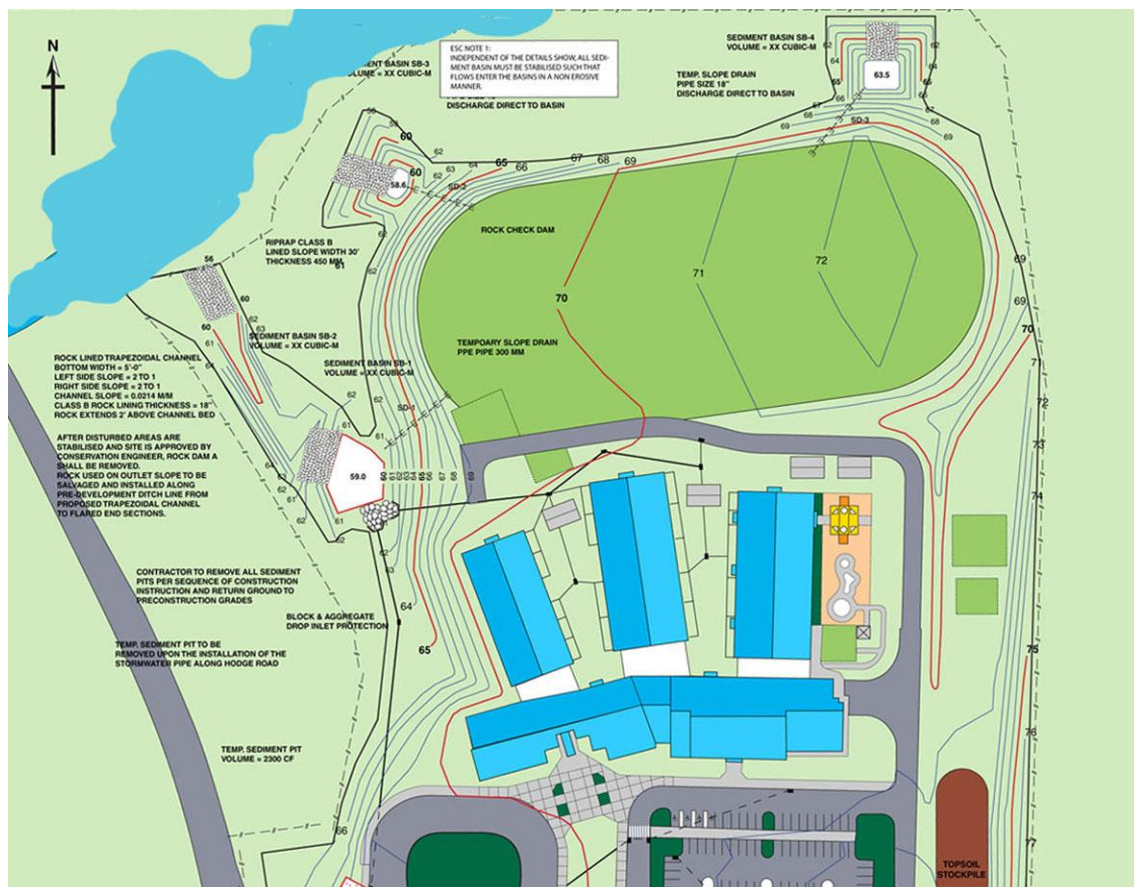


Figure 7 – Original school layout with full-sized sports oval (early draft ESCP)

## Review the development layout



School bus parking area

### Topsoil stockpile area

- Case Study: It was identified that the extent of land clearing would need to expand in order to make space for a large topsoil stockpile area.
- Topsoil could not be stockpiled on the sports oval because of the extensive earthworks required to form the oval.
- Also, it was decided that a separate school bus parking area would be established, thus increasing the number of car parking spaces in the main car park.



Revised design of a running track

### Sports oval

- The original design of the sports oval would have resulted in the formation of a fill batter that would have extended well into the riparian zone of Mingo Creek.
- Upon discussions with the Department of Education, and the council, it was agreed that an alternative location for the sports oval could be found as part of the new residential subdivision currently being approved to the east of the school.
- Consequently, the oval was replaced by a smaller running track.



Replacement of sealed road with dirt road

### Shorten the length of the internal road

- Because of the downsizing of the sports oval, the internal sealed road could be terminated just north of the bus parking area.
- An unsealed dirt road will now extend from the end of the running track.

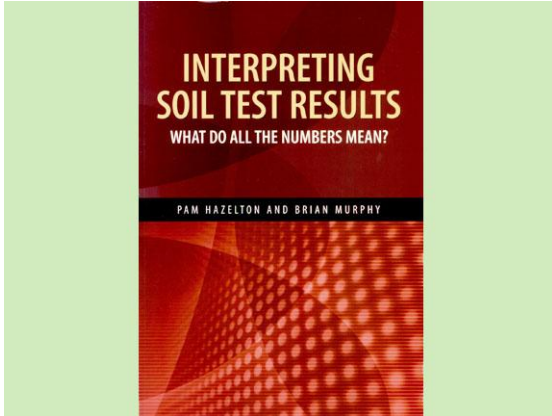


Rehabilitation of sediment basin, SB-4

### Rehabilitation of the sediment basins as part of the permanent stormwater design

- The two most northern sediment basins were identified as being suitable for conversion into bio-retention basins as part of the school's permanent stormwater treatment system, and the continued protection of Mingo Creek.
- Knowledge of this intended retention of these sediment basins will likely change the detailed design of these basins, as well as the connecting drainage network.

### Step 3 – Review soil data



Hazelton & Murphy (2007)

#### Review soil data

- The key issues to identify include:
  - location of **acid sulfate** soils
  - location of **clayey** soils
  - location of **dispersive** soils
  - location of **slaking** soils
  - location of **unstable** soils.
- If you need assistance understanding what the soil data means, then refer to Hazelton and Murphy, 2007, *Interpreting Soil Test Results*.



Photo supplied by Catchments & Creeks Pty Ltd

Hard, clayey soil (1995)

#### Hodge Road Case Study site

- The Department of Education had conducted soil testing during the planning phase, and a soil map has been supplied to all contractors.
- The soil type varies from:
  - non-dispersive clayey soil adjacent to Mingo Bluff Boulevard
  - slightly dispersive clayey soil along the eastern boundary
  - coarse alluvial soils adjacent Mingo Ck
  - no acid sulfate soils were detected.

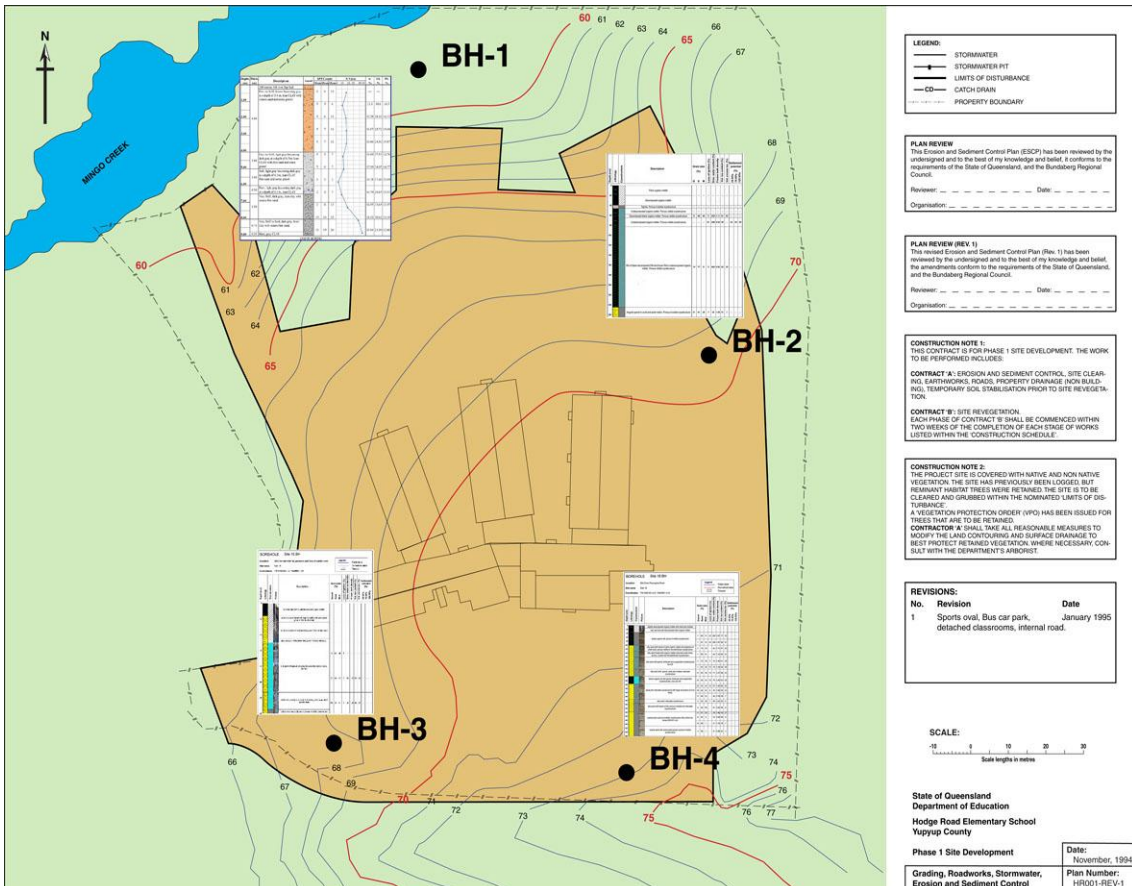


Figure 8 – Soil test bore hole locations for the Hodge Road school site

## Problematic soils



Photo supplied by Catchments & Creeks Pty Ltd

**Culvert damaged by acidic water**

### Acid sulfate soils

- Prior to disturbing any soils below an elevation of 5 m AHD, the soil should be tested for its acid sulfate potential.
- These soils could be acidic, or at least have the potential to become acidic if disturbed.
- Actual and potential acid sulfate soils must be managed in accordance with the local state-approved guidelines.



Photo supplied by Catchments & Creeks Pty Ltd

**'Fluting' erosion within a dispersive soil**

### Dispersive soils

- Ideally, the existence of dispersive soils should be identified during pre-construction soil tests, such as:
  - exchangeable **sodium** percentage > 6%
  - **Emerson** aggregate classes 1 to 5, note classes 3(2), 3(1) and 5 have a slight risk of dispersive problems.
- A simple field test such as the **Aggregate Immersion Test** (see over page) can be used as an on-site indicator of dispersive soils.



Photo supplied by Catchments & Creeks Pty Ltd

**Deep rilling within a sandy soil**

### Slaking soils

- When slaking or non-cohesive (sandy) soils first erode, the erosion is often (but not always) deeper than it is wide, and the sides of the rills are often near-vertical.
- This form of erosion can occur if the soil is:
  - a slaking soil
  - a non-slaking, sandy soil
  - a non-slaking, poorly compacted soil
  - a non-slaking soil that has a very low organic content.



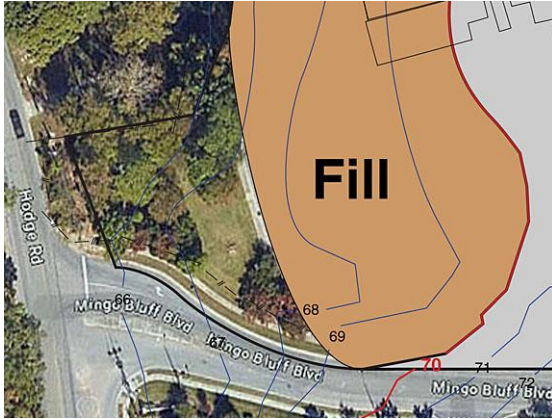
Photo supplied by Catchments & Creeks Pty Ltd

**Failure of earth batter (landslip)**

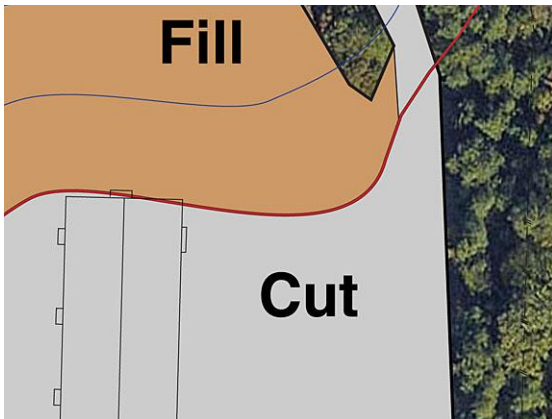
### Unstable soils

- Unstable soils would include areas of the work site that demonstrate a risk of landslip.
- Often these areas can be identified by:
  - long, deep cracks in the soil surface
  - tilted tree trunks.
- The identification of **saline soils** have not been included here because their adverse effect is more on site revegetation rather than on ESC measures.

## Step 4 – Prepare a cut and fill plan



Potential site office location



Potential site soil stockpile location

### Introduction

- A cut and fill plan can be a useful tool in the preparation of an ESCP.
- These plans can be used to:
  - identify the possible staging of earthworks
  - identify areas of low earthworks activity (i.e. along the junction of 'cut' and 'fill'), which can be useful in locating the site office, entry/exit points, and stockpiles
  - assist in the development of the Construction Drainage Plans.

### Hodge Road Case Study site

- The non-cut or fill area at the south-west corner of the property appears to be an ideal location for the placement of the site office and a site entry point.
- The area of land that forms the junction of 'cut' and 'fill' zones, and which is located near the eastern property boundary, may be suitable for the placement of a topsoil stockpile.

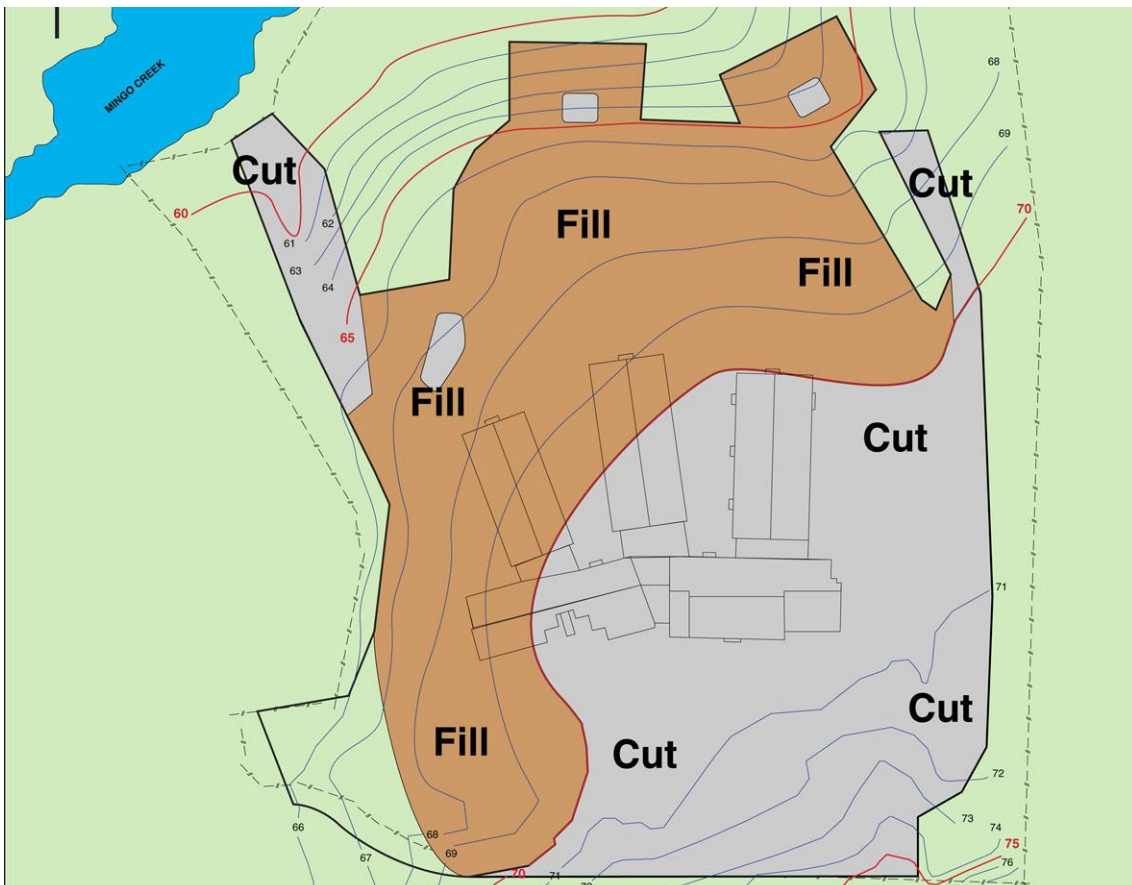
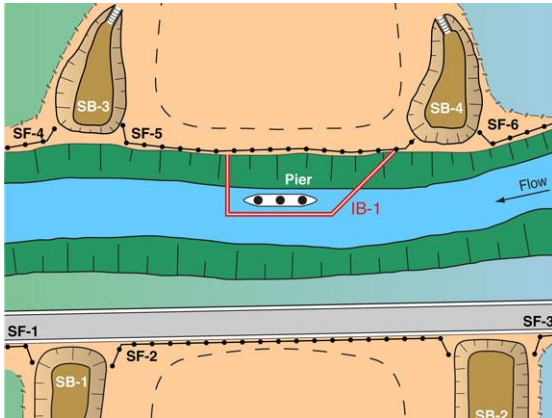
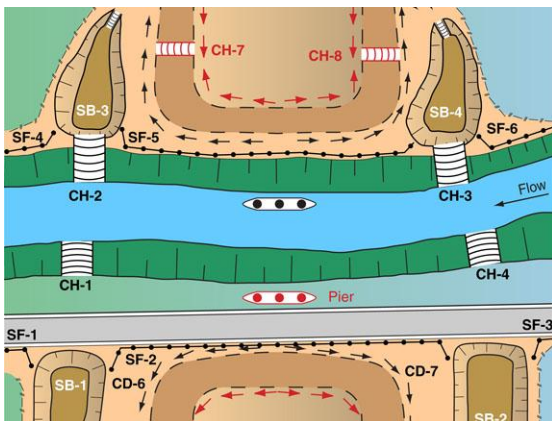


Figure 9 – Earthworks cut and fill plan for the Hodge Road school site

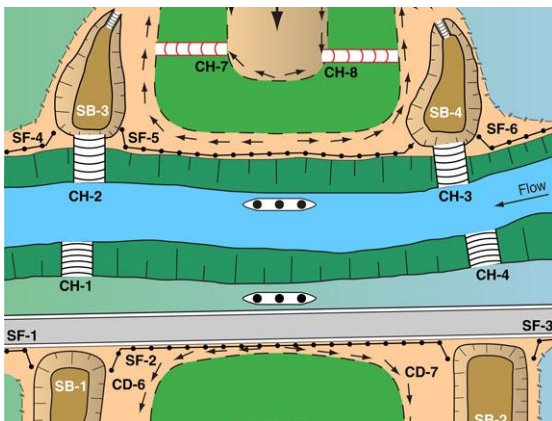
## A brief discussion about work sites with multi-stage earthworks



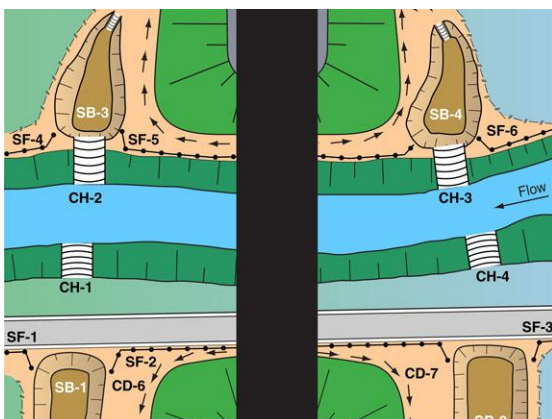
Stage 1



Stage 2



Stage 3



Stage 4

### Introduction

This bridge construction example is discussed in more detail in Chapter 4.

- There are generally two ways of presenting ESCPs for sites with complex earthworks:
  - it may be possible to place all ESC measures on one ESCP, and then use an [Installation Sequence](#) to identify when each ESC item needed, or
  - produce individual ESCPs for each stage of earthworks.

### Stage 2

- Stage 2 of this bridge construction focuses on controlling the movement of 'dirty' water through the site, and directing this runoff to sediment basins.

### Stage 3

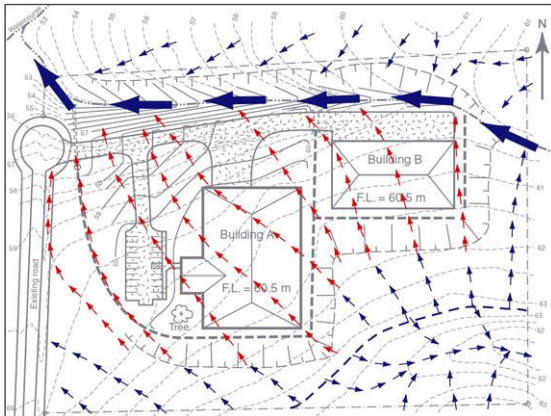
- Stage 3 of the earthworks focuses on stabilising any completed areas of earthworks.

### Stage 4

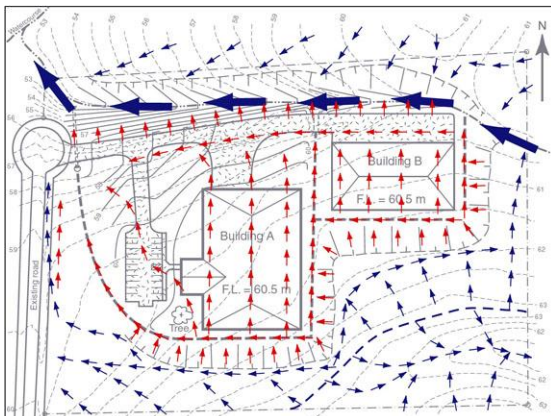
- Stage 4 focuses on those erosion and sediment controls that need to be operational while the bridge and roadway are being constructed.

Now, back to the general discussion about the preparation of ESC Plans.

## Step 5 – Prepare a Construction Drainage Plan



Drainage on factory site after land clearing



Drainage on factory site after earthwork

### Introduction

- **Construction Drainage Plans** differ from normal drainage plans because they refer to the **temporary** drainage conditions that are expected to exist during a given stage of the construction.
- Construction Drainage Plans may not need to be submitted as attachments to the ESCP.
- These drainage plans are only prepared for the purpose of assisting in the development of Erosion and Sediment Control Plans (ESCP).

### Construction Drainage Plans

- Ideally a Construction Drainage Plan is sketched for each phase of construction, and should show:
  - flow entry and exit points
  - areas of sheet and concentrated flow
  - sub-catchment boundaries
  - all permanent and temporary roads
  - all temporary and permanent drainage control measures expected to exist during that stage of earthworks.

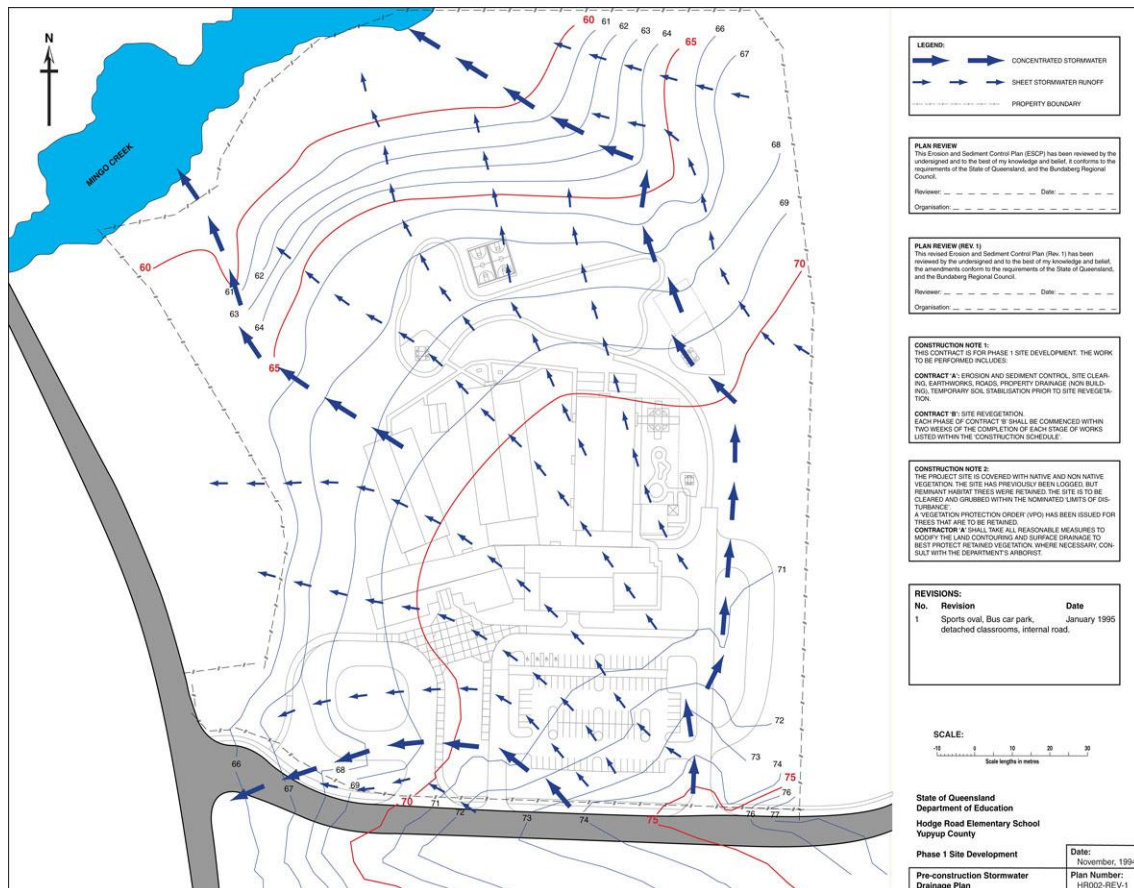


Figure 10 – Construction Drainage Plan for the Hodge Road school site

## Construction Drainage Plans



Site entry located on an overland flow path



Mud generated around a site office



Stockpile locate on an overland flow path



Access road located along a flow path

### Site entry/exit points

- If the work site is located up-slope of the public road, then it is likely that the site's access to this public road would form a low point on the work site.
- It is important to direct any stormwater runoff to a stable outlet, and along a travel path not shared by vehicles:
  - a flow diversion berm (speed bump) may be placed at the top of the access
  - a lined drainage chute may be formed down the side of the access road.

### Site office

- The site office, car park and material stockpiles should not be located along a concentrated overland flow path.
- ALL land acts as an overland flow path during heavy storms, but it is the travel path of **concentrated flows** that need to be avoided, not the areas of sheet flow.
- That said, any run-on water that is moving towards the site office should be diverted around the office compound.

### Stockpiles

- It may seem logical to locate soil stockpiles on 'flat' land, such as along the invert (low point) of a valley; however, this is also the most likely location for the travel path of concentrated overland flow.
- Stockpiles of erodible materials, such as sand and soil, are best located on slightly sloping ground, away from concentrated overland flow paths.

### Access roads/tracks

- Permanent roadways are often designed to act as overland flow paths during major storms.
- Temporary construction access roads and tracks are usually recessed into the earth due to topsoil removal, and possible ongoing soil compaction.
- All roads and tracks need to be marked on Construction Drainage Plans because these roads and tracks can cause the wanted, or unwanted, diversion of flows.

## Step 6 – Locate traffic entry/exit points and associated ESC measures



Photo supplied by Catchments & Creeks Pty Ltd

### Divided site entry and exit lanes



Photo supplied by Catchments & Creeks Pty Ltd

### Control of rocks carried from rock pads

### Site entry/exit points

- Restrict site access to the minimum number of entry/exit points.
- Entry/exit points are normally located away from areas of significant cut or fill.
- On large sites it may be desirable to provide a separate entry/exit point for light vehicles (i.e. cars) and one for heavy vehicles.
- Providing separate entry and exit lanes could allow some drivers to bypass the exit lane's sediment trap!
- Avoid placing site entry/exit points at the lowest elevation along the road frontage because this is likely to be a location where a major sediment trap needs to be constructed.
- If the site, or access road, is elevated above the public roadway, and if stormwater runoff from the work site is likely to wash across the entry/exit point towards the roadway, then a cross-berm (speed bump) needs to be formed across the entry/exit sediment trap to direct any site runoff towards an appropriate sediment trap.

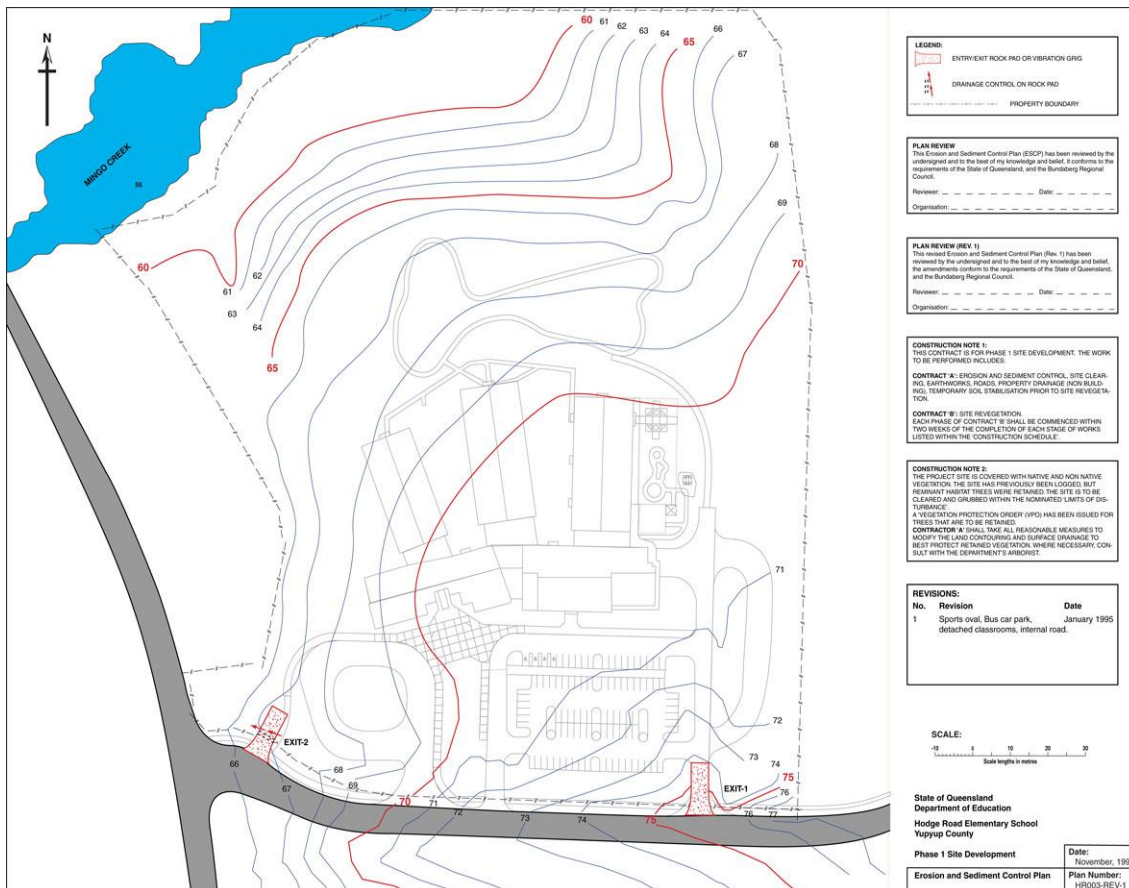


Figure 11 – Stabilised site entry/exit points for the Hodge Road school site

## Site entry and exit points



**Rock pad**

### Rock pads (Exit)

- Rock entry/exit pads are suitable for all soil types.
- The critical design parameter is the total void spacing between the rocks, within which the sediment is to be retained.
- Minimum 15 m length.
- The width of the rock pad is not critical.
- Requires a geotextile underlay.
- [Rock Pads](#) perform better than [Vibration Grids](#) during wet weather.



**Vibration grid**

### Vibration grids (Exit)

- Vibration grids are best suited to sandy soils.
- They can also be used in clayey soil regions to control sediment movement from heavy construction traffic during periods of dry weather.



**Vehicle wash-down area**

### Modified vibration grid design

- Welding reinforcing mesh over a standard vibration grid can reduce potential damage to construction vehicles caused by excessive vehicle vibration.
- Such surfaces can also be used as manual wash-down areas for both:
  - dirt, and
  - weed seed.



**Wash bay**

### Wash bays (Exit)

- Wash bays are preferred when:
  - working near fragile environments
  - when turbidity control is critical, or
  - when working with highly cohesive (sticky) clays.
- Wash bays generally need to operate as 'dry' vibration grids during periods of dry weather, otherwise the wash bay can lead to mud being generated on the access track, which can then be tracked off the site onto public roads.

## Step 7 – Locate and protect the site office and stockpile areas



Site entry and office



Office compound

### Site office

- The location of the site office, car park, stockpile, borrow pit, and material storage areas all need to be placed on the ESCP.
- The site office should be located close to the main site entry point so that visitors to the site are not forced to travel through the construction site before being informed that they are not allowed to travel, unaccompanied, through the construction site.
- Temporary drainage, erosion and sediment controls should be identified.

### Office compound

- These areas should be positioned:
  - away from overland flow paths
  - in such a location as to minimise overall land disturbance.
- If soil stockpiles are located near the site office or car park, then either:
  - place the stockpiles down-slope of the office and car park so that dirty water draining from the stockpiles does not generate mud within the compound, or
  - place appropriate drainage diversions.

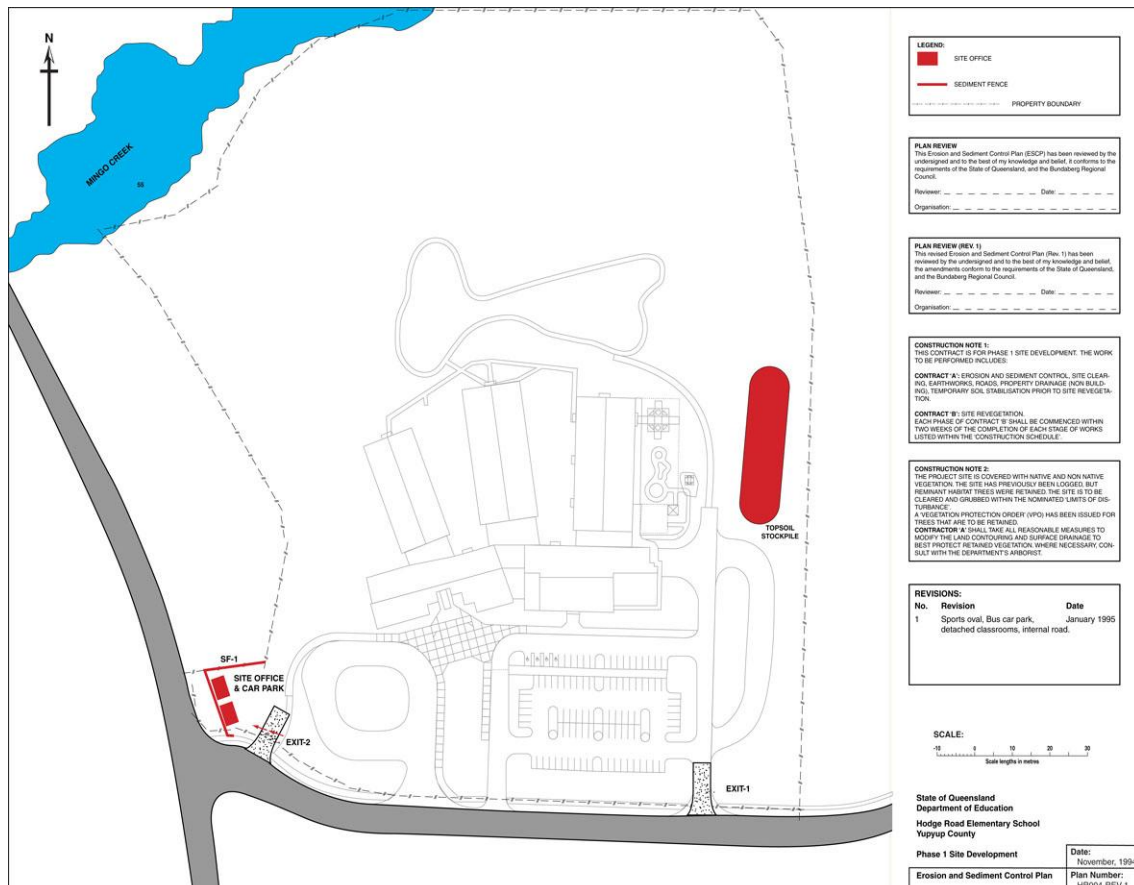


Figure 12 – Proposed site office, car park and stockpile areas

## Office compound



### Storage lock-up



### ESC materials



### Painting equipment cleaning



### Temporary stormwater drainage

### Equipment lock-up

- Consider the need for lock-up storage sheds.
- If needed, then space must be allocated for their use.

### ESC materials

- Allow for the storage of all necessary materials to establish and maintain the site's erosion and sediment control (ESC) measures.
- The materials shown left are [jute blanket](#) (top), [shade cloth](#) (not used for erosion or sediment control), and [filter cloth](#) (bottom).

### Wash-up areas

- Areas may need to be allocated for:
  - cement truck wash-out
  - disposal of excess concrete
  - disposal of collected sediment
  - cleaning of painting equipment
  - cutting ceramic tiles
  - cutting bricks, pavers and masonry blocks.

### Site office drainage

- Where appropriate, determine an appropriate method for disposing roof water discharging from the site offices.
- This water should be directed away from the work site and any common walking and access areas to minimise the generation of mud during wet weather.

## Stockpile management



**Topsoil stockpile placed on public roadway**



**Flow diversion using a catch drain**



**Long-term stockpile covered with jute**



**Sediment control down-slope of stockpile**

### Location of stockpiles

- Ensure that sand/soil/earth stockpiles are not located in a position where the material could cause harm, or be washed into a gutter, drain or water body.
- Do not locate stockpiles:
  - on a road pavement
  - within an overland flow path
  - adjacent to stream banks
  - within the 'drip zone' of protected trees (long-term stockpiles).

### Diversion of up-slope runoff

- Ensure, where necessary, a [Flow Diversion Bank](#), or [Catch Drain](#), is placed up-slope of a stockpile to direct excessive overland flow around the stockpile.
- Flow diversion around sand/soil/earth stockpiles is generally considered necessary when rainfall is possible and the up-slope catchment area exceeds 1500 m<sup>2</sup>.

### Erosion control measures

- Ensure that long-term stockpiles of material containing some degree of clayey matter (e.g. most soils) are:
  - ideally covered with an impervious cover (this may not always be practical)
  - covered with [Mulch](#) or temporary vegetation (grass) if not located within the drainage catchment of a sediment basin.
- If the stockpiled soil is to be used to form an embankment, then it is not desirable to add any form of organic matter to the soil.

### Sediment control measures

- Ensure an appropriate sediment control system is located down-slope of sand/soil earth stockpiles, such as:
  - [Filter Fence](#), or [Sediment Fence](#), for clayey soils
  - Woven [Sediment Fence](#) for washed sand
  - [Sediment Basin](#) wherever practical.

## Step 8 – Identify potential areas of non-disturbance



Photo supplied by Catchments & Creeks Pty Ltd

**Sediment fence located in bushland**

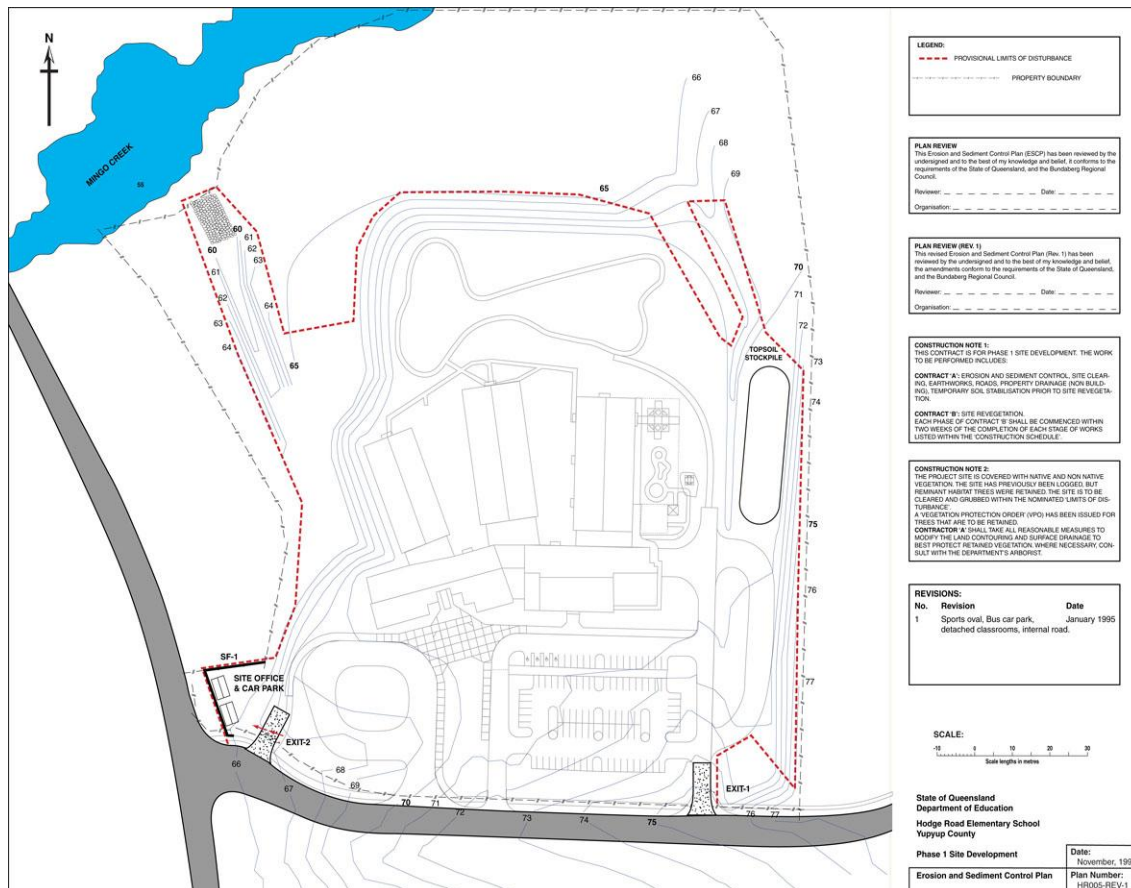


Photo supplied by Catchments & Creeks Pty Ltd

**Habitat tree located in a pipeline corridor**

### Explanation

- Obviously the final limits of disturbance can only be known after all ESC measures have been identified, including all sediment basins.
- However, at this stage it can be useful to mark out potential non-disturbance areas for the following reasons:
  - clear identification of protected vegetation (e.g. critical habitat trees)
  - to reduce the risk of placing an ESC measure within a potential non-disturbance area if an alternative location is available
  - avoid the placement of sediment fences across retained bushland, vegetation protection zones, or other non-disturbance areas
  - help identify potential construction problems where the proposed width of land disturbance will not allow adequate access for construction vehicles, or the space needed to perform the construction process.
- The final limits of disturbance will be identified in a later step.



**Figure 13 – First estimate of the limits of disturbance for the Hodge Road school site**

## Step 9 – Review access roads and temporary watercourse crossings



Temporary construction access road



Access road crosses between SB-1 & SB-2

### Introduction

- All temporary construction and access roads should be shown on the ESCP.
- All necessary drainage, erosion and sediment control measures associated with these roads should be shown on the ESCP, or in the technical notes.
- Where practical, allow stormwater to shed from these roads at regular intervals—this runoff should be directed towards an appropriate sediment trap.

### Hodge Road Case Study site

- There are no watercourse crossings on the school site; however, the temporary access road does pass between sediment basins SB-1 and SB-2.
- The rock-lined spillway of SB-1 will act as a stabilised 'ford' crossing as shown in the 1995 site photo (left).
- A dirty water table drain will be formed along the edge of this access road to direct sediment-laden water to sediment basins SB-1, SB-3 and SB-4.

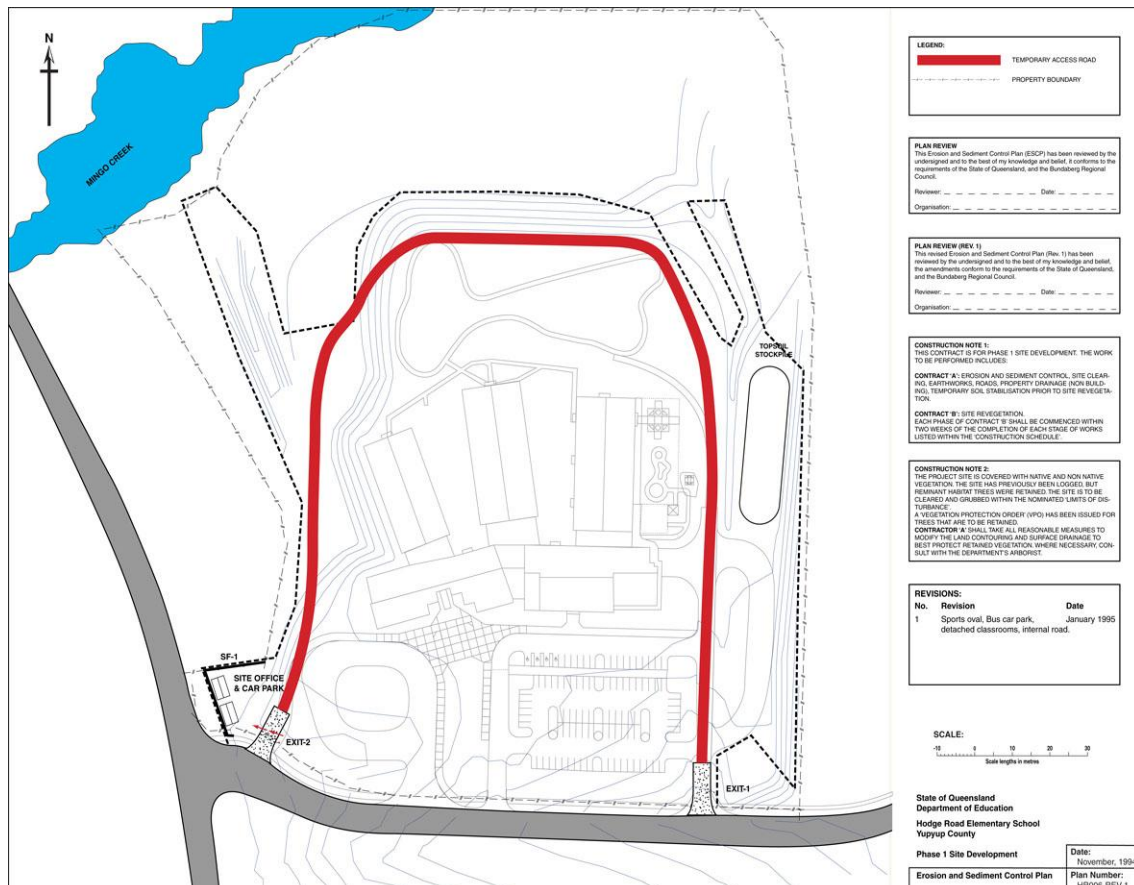


Figure 14 – Temporary, unsealed, construction access road on school site

## Temporary watercourse crossings



Photo supplied by Catchments & Creeks Pty Ltd

**Temporary access construction bridge**



Photo supplied by Catchments & Creeks Pty Ltd

**Temporary pipe culvert**



Photo supplied by Catchments & Creeks Pty Ltd

**Ford crossing of a sand-based creek**



Photo supplied by Catchments & Creeks Pty Ltd

**Barge crossing of a tidal inlet**

### Temporary bridge crossings (TBC)

- A temporary bridge crossing is used when it is important to maintain fish passage during the construction period.
- Pre-cast culvert bridging-slabs (left) can be used to form a bridge deck across narrow streams.
- It is important to control stormwater drainage on the access tracks leading to watercourse crossings to minimise sediment-laden water entering the watercourse.

### Temporary culvert crossings (TCC)

- Temporary culvert crossings are typically used on wide stream crossings.
- They are best used when fish passage is not critical; however, suitable fish passage can be achieved through appropriate culvert design.
- Recycled steel pipes are commonly used for this purpose.

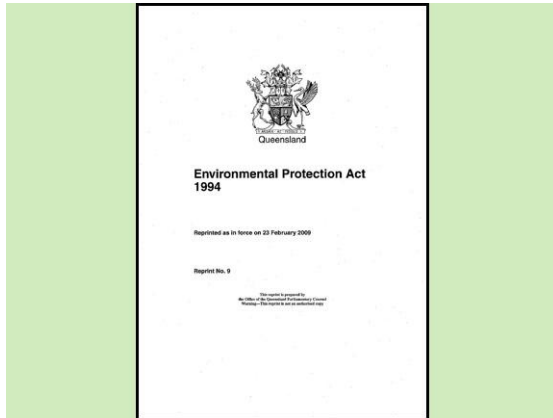
### Temporary ford crossings (TFC)

- Ford crossings are used on alluvial creek and dry-bed waterways when stream flows are not expected.
- The regular crossing of 'wet' creek beds by construction vehicles should be avoided.
- [Cellular Confinement Systems](#) can be used to stabilise dry sandy-bed crossings.

### Alternative waterway crossings

- A barge can be used as a mobile transportation system to cross estuaries and protected waterways.
- Barges can be used as a fixed bridge structure (left) to cross narrow estuary inlets.

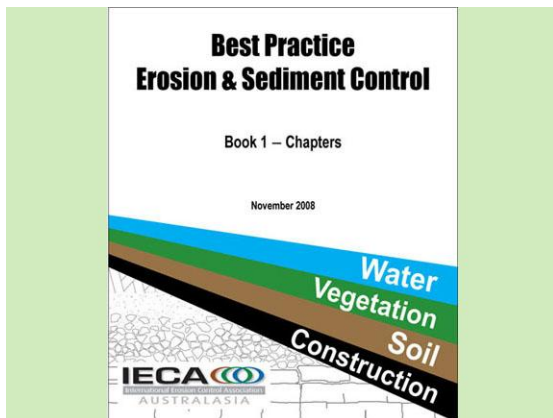
## Step 10 – Determine the required sediment control standard



Environmental legislation

### Introduction

- The sediment control standard can be:
  - specified in legislation
  - specified by the regulator
  - specified within an industry code
  - specified within an Environmental Impact Statement (EIS).
- The sediment control standard may be:
  - applied to the whole work site, or
  - applied individually to each drainage sub-catchment (**preferred**).



IECA (2008) – Book 1

### Hodge Road Case Study site

- Below is the sediment control standard presented in the 2008 edition of the IECA (Australasia) Best Practice ESC document (which is currently under review).
- Our Case Study site would attract a Type-1 sediment control standard.

### 4.5.1 Sediment control standard

In the absence of a locally adopted sediment control standard, Table 4.5.1 is presented as the default, best practice, sediment control standard.

Table 4.5.1 – Sediment control standard (default) based on soil loss rate

Area limit (m <sup>2</sup> ) <sup>[1]</sup>	Soil loss rate limit (t/ha/yr) <sup>[2]</sup>			Soil loss rate limit (t/ha/month) <sup>[3]</sup>		
	Type 1	Type 2	Type 3	Type 1	Type 2	Type 3
250	N/A	N/A	[4]	N/A	N/A	[4]
1000	N/A	N/A	All cases	N/A	N/A	All cases
2500	N/A	> 75	75	N/A	> 6.25	6.25
>2500	> 150	150	75	> 12.5	12.5	6.25

Notes: [1] Area is defined by the catchment area draining to a given location. The area does not include any “clean” water catchment that bypasses the sediment trap.

[2] Soil loss rate limit defines the maximum allowable soil loss rate from a given catchment area draining to a given sediment trap at any given instant within the construction phase.

[3] Soil loss rate limit defines the maximum allowable soil loss rate from a given catchment area draining to a given sediment trap at any given instant within a given month in those cases where the actual time of construction is regulated.

[4] Refer to the relevant regulatory authority for assessment procedures. The default standard is a Type 3 sediment trap.

Table 4.5.1 extracted from IECA (Australasia) Best Practice ESC (2008)

**Table 4 – Classification of sediment traps based on particle size**

Classification	Minimum particle size	Typical trapped particles
Type 1	<0.045 mm	Clay, silt and sand
Type 2	0.045 to 0.14 mm	Silt and sand <sup>[1]</sup>
Type 3	>0.14 mm	Sand
Supplementary	>0.42 mm	Coarse sand

[1] Technically, silt particles have a grain size between 0.002 and 0.02 mm, which means that only Type-1 sediment traps are likely to capture silt-sized particles. However, for general discussion purposes, it can be assumed that Type 2 systems capture a significant proportion of silt-sized particles.

**Table 5 – Default classification of sediment control techniques**

Type 1	Type 2	Type 3
<b>Sheet flow treatment techniques</b>		
<ul style="list-style-type: none"> <li>• Buffer Zone capable of infiltrating 100% of stormwater runoff or process water *</li> <li>• Infiltration basin or sand filter bed capable of infiltrating 100% of flow</li> </ul>	<ul style="list-style-type: none"> <li>• Buffer Zone * capable of infiltrating the majority of flows from design storms</li> <li>• Compost/Mulch Berm</li> </ul>	<ul style="list-style-type: none"> <li>• Buffer Zone *</li> <li>• Filter Fence</li> <li>• Modular Sediment Trap</li> <li>• Sediment Fence</li> </ul>
<b>Concentrated flow treatment techniques</b>		
<ul style="list-style-type: none"> <li>• Sediment Basin * (sized in accordance with design standard)</li> </ul>	<ul style="list-style-type: none"> <li>• Block &amp; Aggregate Drop Inlet Protection</li> <li>• Excavated Sediment Trap with Type 2 outlet</li> <li>• Filter Sock</li> <li>• Filter Tube Dam</li> <li>• Mesh &amp; Aggregate Drop Inlet Protection</li> <li>• Rock &amp; Aggregate Drop Inlet Protection</li> <li>• Rock Filter Dam</li> <li>• Sediment Trench *</li> <li>• Sediment Weir</li> </ul>	<ul style="list-style-type: none"> <li>• Coarse Sediment Trap</li> <li>• Excavated Drop Inlet Protection *</li> <li>• Excavated Sediment Trap with Type 3 outlet</li> <li>• Fabric Drop Inlet Protection</li> <li>• Fabric Wrap Field Inlet Sediment Trap</li> <li>• Modular Sediment Trap</li> <li>• Straw Bale Barrier</li> <li>• U-Shaped Sediment Trap</li> </ul>
<b>De-watering sediment control techniques (selection not based on soil loss rate)</b>		
<ul style="list-style-type: none"> <li>• Sediment Basin</li> <li>• Stilling Pond</li> </ul>	<ul style="list-style-type: none"> <li>• Filter Bag or Filter Tube</li> <li>• Filter Pond</li> <li>• Filter Tube Dam</li> <li>• Portable Sediment Tank *</li> <li>• Settling Pond *</li> <li>• Sump Pit</li> </ul>	<ul style="list-style-type: none"> <li>• Compost Berm *</li> <li>• Filter Fence *</li> <li>• Grass Filter Bed *</li> <li>• Hydrocyclone *</li> <li>• Portable Sediment Tank *</li> <li>• Sediment Fence</li> </ul>
<b>Instream sediment control techniques (selection not based on soil loss rate)</b>		
<ul style="list-style-type: none"> <li>• Pump sediment-laden water to an off-stream Sediment Basin, or a high filtration system</li> </ul>	<ul style="list-style-type: none"> <li>• Filter Tube Barrier</li> <li>• Modular Sediment Barrier*</li> <li>• Rock Filter Dam</li> <li>• Sediment Weir</li> </ul>	<ul style="list-style-type: none"> <li>• Modular Sediment Barrier*</li> <li>• Sediment Filter Cage</li> </ul>

\* Classification depends on design details.

## Types of sediment traps



**Sediment basin (Type 1)**



**Rock filter dam (Type 2)**



**Sediment fence (Type 3)**



**Sag inlet protection (Supplementary)**

### Type 1 sediment traps

- Within this document, sediment traps have been grouped into [Type 1](#), [Type 2](#), [Type 3](#) or [Supplementary](#) sediment traps.
- Type 1 sediment traps are designed to collect a full range of sediment particles down to less than 0.045 mm.
- In general, these traps target particle sizes from clay particles to sand grains.
- Type 1 sediment traps include [Sediment Basins](#) and some of the advanced filtration systems used in de-watering operations.

### Type 2 sediment traps

- Type 2 sediment traps are designed to capture sediments down to a particle size of between 0.045 and 0.14 mm.
- In general, these sediment traps target particle sizes from sands down to coarse silts.
- Type 2 sediment traps generally do **not** reduce turbidity levels (i.e. water clarity).
- Type 2 sediment traps include [Mulch Berms](#), [Rock Filter Dams](#), [Sediment Weirs](#) and [Filter Ponds](#).

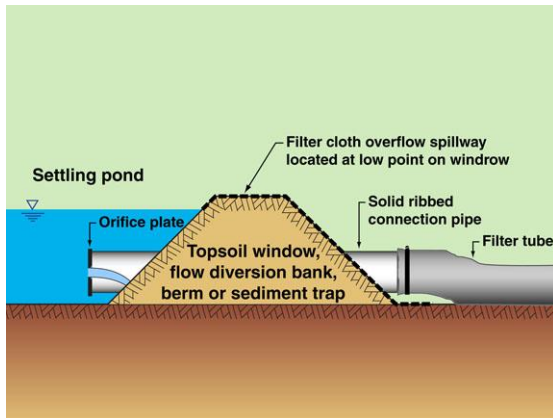
### Type 3 sediment traps

- Type 3 sediment traps are primarily designed to trap coarse-grained particles larger than 0.14 mm.
- These traps may capture some fines, but not as much as a Type 2 sediment trap.
- These traps include [Sediment Fences](#), [Buffer Zones](#) and some stormwater inlet protection systems.
- There should be **no** expectation of a change in water colour (turbidity) as flows pass through a Type 2 or 3 sediment trap.

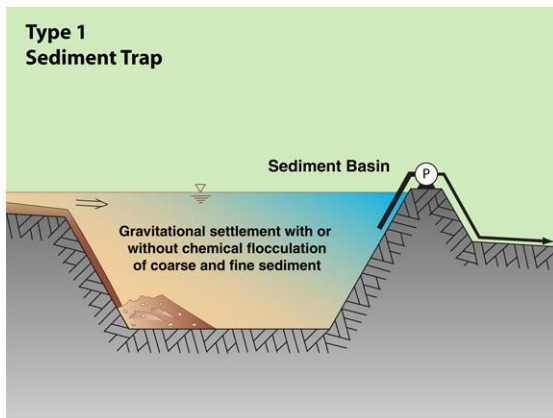
### Supplementary sediment traps

- Some sediment traps, such as [Grass Filter Strips](#) and most kerb inlet sediment traps, have such limited efficiency, or are so easily damaged by vehicles, that they can only be used to *supplement* a Type 1, 2 or 3 sediment trap.
- Even though these sediment traps are potentially unreliable, their use on urban construction projects is still considered to be a component of *'taking all reasonable measures to prevent or minimise environmental harm'*.

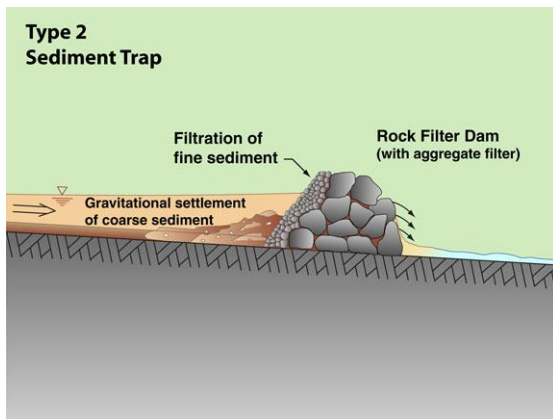
## Types of sediment traps



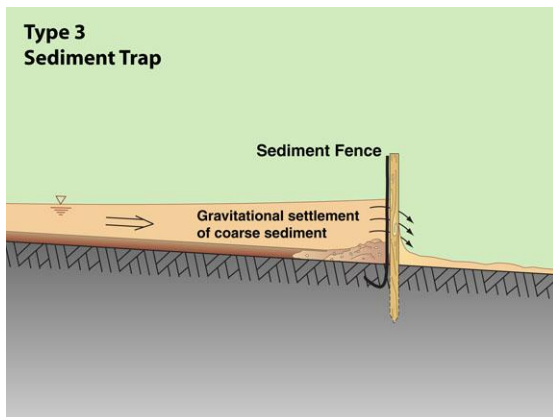
Sediment trap with filter tube outlet



Type 1 treatment system



Type 2 treatment system



Type 3 treatment system

## Mechanics of sediment traps

- The mechanics of sediment trapping can generally be categorised into the following groups:
  - ponding traps that primarily utilise gravity-induced particle settlement
  - extended detention settling basins
  - traps that utilise filtration processes to treat minor flows:
    - geotextile filters
    - sand and aggregate filters
    - compost filters.

## Type 1 sediment traps

- Type 1 sediment traps utilise either:
  - extended detention to encourage the settlement of clay-sized particles; or
  - super-fine, high-pressure filters.
- Sediment basins operate as either:
  - continuous-flow 'dry' basins; or
  - plug-flow 'wet' basins.
- High-pressure filters are normally only used during specialised de-watering operations.

## Type 2 sediment traps

- The key components of a Type 2 sediment trap are a 'settling pond' and the 'coarse-particle filter'.
- Just like a [Sediment Fence](#), a Type 2 sediment trap is designed to encourage the ponding of water up-slope of the trap.
- Gravity-induced settlement is then followed by a geotextile, aggregate, or compost filter.
- A [Compost Filter](#) is simply a compost berm or compost-filled 'sock'.

## Type 3 sediment traps

- Most Type 3 sediment traps are designed to slow the passage of water to such a degree that ponding occurs up-slope of the trap.
- It is this ponding of water that allows gravity-induced settlement of the coarser grained particles (i.e. sands).
- A sediment fence is **not** a 'filter'.
- A sediment fence is just a porous dam that encourages sediment-laden water to pond up-slope of the fence.

## Types of sediment filters



Photo supplied by Geofabrics Australasia

**Sand-filled filter sock**



Photo supplied by Catchments & Creeks Pty Ltd

**Rock filter dam with aggregate filter**



Photo supplied by Catchments & Creeks Pty Ltd

**Filter tube outlet on a Type 2 sediment trap**



Photo supplied by the Integrated Group

**Compost-filled filter sock**

## Types of sediment filters

- The filter media may consist of sand, aggregate, geotextile, or compost (straw-based filters are ineffective).
- Their primary purpose of such filters is usually to encourage the ponding of water (i.e. gravity settlement); however, some degree of filtration does occur.
- **Sand-based filters** are partially effective, have a low discharge rate, can quickly block with sediment, and can be difficult and messy to maintain.

## Aggregate filters

- The most important thing to know about aggregate filters is that they rely on the effects of partial sediment blockage in order to activate the filtration process.
- A filter formed from clean aggregate initially does **not** provide much filtration; at best it simply helps to slow water flow to encourage up-slope ponding.
- Only after sediments begin to partially block the filter do aggregate filters begin to work effectively, which means they are better used on long-term projects.

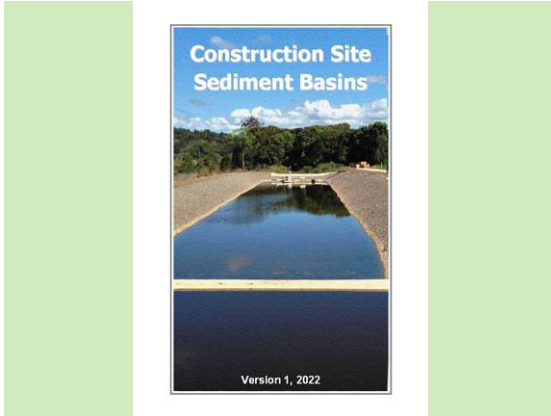
## Geotextile filters

- Geotextile filters utilise non-woven fabrics (woven fabrics should **not** be used).
- Most geotextile filters initially have a high flow rate, but sediment blockage can eventually reduce this to zero.
- The use of geotextile filters is preferred if the trap has a short operational period, or the capture of fine sediments is critical.
- Geotextile filters do not reduce turbidity, if the water goes in 'brown', it will come out 'brown'.

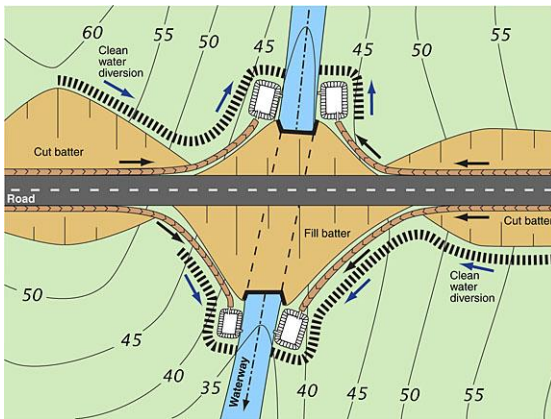
## Compost filters

- Compost filters use both **filtration** and **adsorption** processes to clean the through-flow.
- Compost filters can adsorb minor amounts of dissolved and fine particulate matter, such as metals.
- These filters generally perform better than most sand, aggregate, and geotextile filters, provided the filter remains undamaged, and flows are not allowed to bypass the filter (e.g. pass under the filter).

## Step 11 – Locate major sediment traps



Construction site sediment basins, 2022



Road construction over a waterway

### Locating sediment basins

- Issues to consider when locating sediment basins include:
  - the full size of the basin, including earth embankment, emergency spillway, and energy dissipater
  - possible incorporation of the basin into the site's permanent stormwater treatment system
  - maximising the collection of sediment-laden runoff generated within the site during the full construction period
  - ensuring the basin has suitable access for maintenance and de-silting.
- Do not locate a sediment basin within a waterway.
- If construction activities cross a waterway, then it is typical for there to be four basins, located each side of the waterway, and each side of the crossing.
- Case Study site:** To some degree, the basin layout shown below mimics the 1995 site conditions, which may have been suitable in 1995; however, basin design in 2023 would have been very different.

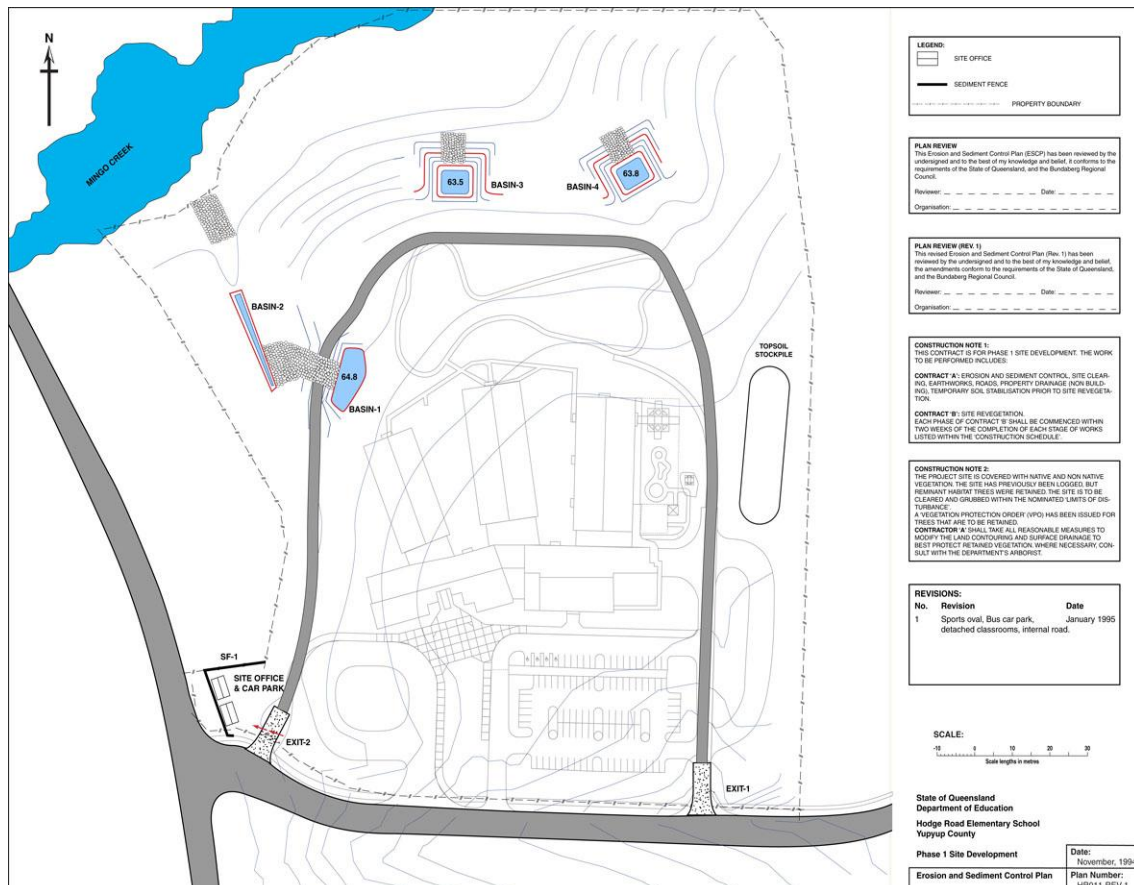
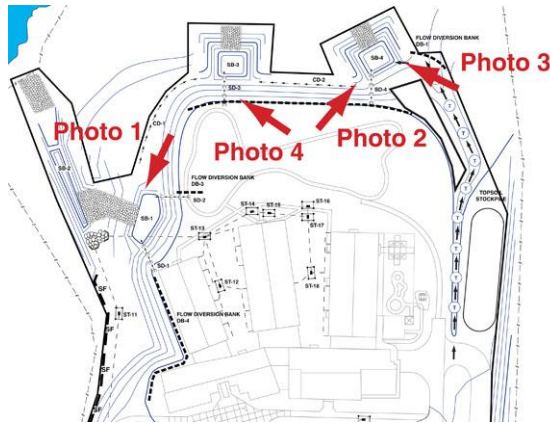


Figure 15 – Proposed sediment basins on the Hodge Road school site

## Hodge Road Elementary School (actual site conditions in 1995)



Direction of view of below photo

### Hodge Road Elementary School

- The actual Hodge Road School is located off Mingo Bluff Boulevard in Knightdale, Wade County, North Carolina, USA.
- The following photos were taken on the construction site on 6<sup>th</sup> April, 1995.
- The photos show:
  - sediment basin 1, a pre-treatment basin
  - sediment basin 3, partially hidden by a fill embankment and retained trees
  - sediment basin 4, with slope drain inlet and rock-lined emergency spillway.



Photo 1: Looking south towards sediment basin 1 and western access road (1995)



Photo 2: Sediment basin 4 (1995)

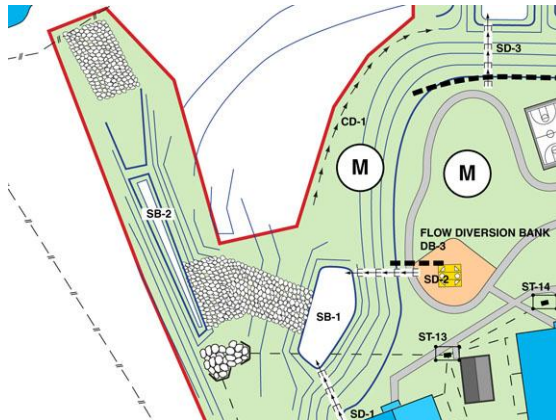


Photo 3: Sediment basin 4 (1995)



Photo 4: Looking north-west towards sediment basin 3 (partially hidden behind trees)

## Sediment basins operating in series

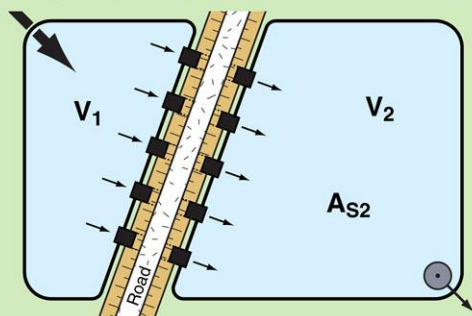


Sediment basins SB-1 and SB-2 in series

## Sediment basins operating in series

- **Case Study:** On the Case Study site it is proposed that SB-1 and SB-2 operate in series.
- Operating basins in 'series' means the water from one basin flows into the next basin, and so on.
- Several basins operating in series can have significantly less sediment trapping efficiency than a single basin, even though the series of smaller basins may have the same total surface area and volume as a single large basin.

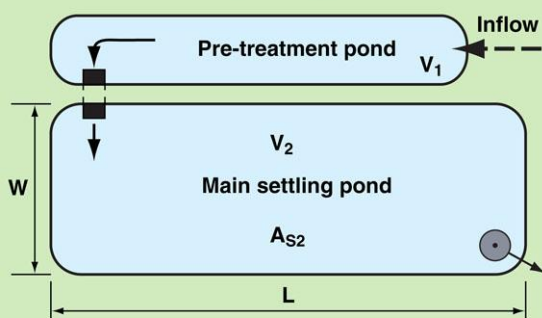
$$V_1 + V_2 = \text{Required minimum volume}$$



$$A_{S2} = \text{Required minimum surface area}$$

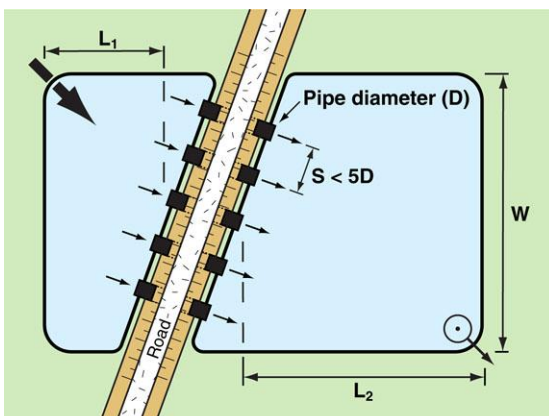
Divided Type A basin

$$V_1 + V_2 = \text{Required Type D volume}$$



$$A_{S2} = \text{Required Type C surface area}$$

Type C basin with pre-treatment pond



Divided Type C basin

## Circumstances where a series of divided basins can be used

- Basins that possibly could operate in series include:
  - Type A basins where the combined basin volume satisfies the minimum volume requirement, and at least one of the basins is able to satisfy the minimum surface area requirement.

## Further to the above

- Other basins that possibly could operate in series include:
  - Type D basins where at least one of the basins has sufficient surface area and length to width ratio to satisfy the requirements of a Type C basin.
    - The combined *settling volume* of the basins must not be less than that specified for a Type D basin.
  - A series of Type C or D basins where each settling pond is connected by several pipes evenly spaced across the basin.
    - Such a design must minimise the effects of inflow jetting from each pipe, and allow an even distribution of flow across the full basin width.
    - In such cases the minor sediment remixing that occurs as flow passes through the pipes is usually compensated by the improved hydraulic efficiency of the overall basin surface area.

## Sediment basin safety fencing



**Fenced sediment basin adjacent to a creek**



**Preparation of ESCP**



**Very steep and slippery bank slope**



**Type C sediment basin with grassed banks**

### Introduction

- Construction sites are often located in publicly accessible areas.
- In general it is not reasonable to expect a parent or guardian of a child to be aware of the safety risks associated with a near-by construction site.
- Thus fencing of a sediment basin may be warranted even if the basins are located adjacent to other permanent water bodies, such as a stream, lake, or wetland.

### Designer's responsibility

- Designers of sediment basins have a duty of care to investigate the safety requirements of the site on which the basins are to be constructed.

### Safety risks

- Responsibility for safety issues on a construction site ultimately rests with the site manager; however, each person working on a site has a duty of care to act in accordance with the state's work-place safety legislation.

### Turfing

- If public safety is a concern, and the basin's internal banks are steeper than 1:5 (V:H), and the basin is not intended to be fenced, then a suitable method of egress during wet weather must be installed.
- Examples of suitable egress include: a side ladder, steps cut into the bank, or at least one bank turfed for a width of at least 2 m from the top of bank to the toe of bank.

## Rock filter dams (RFD) – Type 2 sediment trap for concentrated flows



**Rock filter dam with aggregate filter**



**Rock filter dam with geotextile filter**



**Rock filter dam with aggregate filter**



**Excavated sediment trap and RFD**

### Use of rock filter dams

- A [Type 2](#) sediment trap.
- Rock filter dams can be used as sediment traps connected to the outlets of mulch berms and topsoil windrows.
- Rock filter dams wrapped in filter cloth can also be used as 'instream' sediment traps when working in ephemeral channels.

### Rock filter dam with geotextile filter (RFD)

- Rock filter dams are used in locations where it is impractical to construct a formal [Sediment Basin](#).
- The critical design parameter is the surface area of the settling pond, which needs to be maximised.
- The incorporation of filter cloth is the preferred construction technique if the removal of fine-grained sediment is critical.

### Rock filter dam with aggregate filter (RFD)

- Aggregate-based filtration systems are best used in sandy soil areas.
- Aggregate filters generally rely on the effects of partial sediment blockage to achieve their optimum filtration performance.
- These filters are normally used on long-term sediment traps, and sediment traps that are likely to be regularly de-silted.

### Sediment collection pits

- **Caution:** placing an excavated pit immediately up-slope of an 'aggregate filter' may reduce the filtration performance of the rock filter dam.
- It is noted that aggregate filters rely upon the partial blockage of the aggregate with coarse and fine sediments in order to commence the 'filtration' process.

## Sediment weirs (SW) – Type 2 sediment trap for concentrated flows



Photo supplied by Catchments & Creeks Pty Ltd

**Sediment weir (field inlet protection)**

### Use of sediment weirs

- A **Type 2** sediment trap
- Sediment weirs are used where space is limited (i.e. when space is not available for the construction of a **Rock Filter Dam**).
- Sediment weirs can be very effective in conditions of high flow rates where the sediment trap may be subjected to regular over-topping flows.
- They can also be used as a primary outlet structure on a Type 2 sediment basin (as is the case shown left).

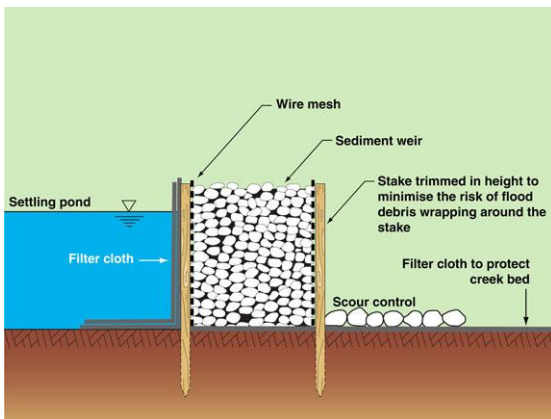


Photo supplied by Catchments & Creeks Pty Ltd

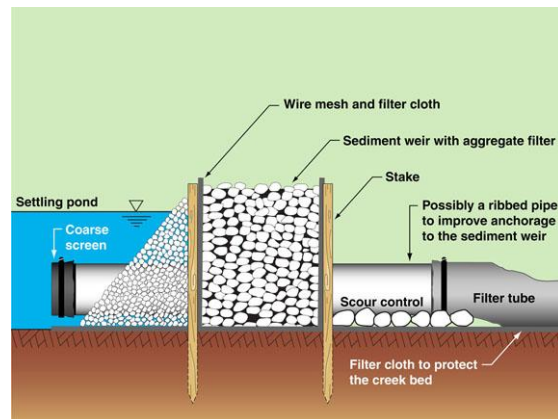
**Sediment weir**

### Use as an instream sediment trap

- Sediment weirs can be used as temporary instream sediment traps for construction works within drainage channels and minor waterways that are likely to experience only minor dry weather flows.
- **Filter Tubes** can be incorporated into the sediment weir to increase the treatable flow rate.
- The critical design parameter is the 'surface area' of the upstream settling pond, which needs to be maximised.



**Sediment weir with aggregate filter**



**Sediment weir with filter tube**



Photo supplied by Adam Pullen

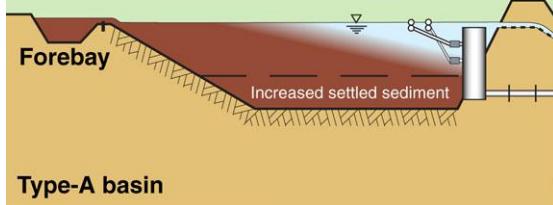
**Construction of a sediment weir**

### Construction difficulties

- Sediment weirs can also be used when crossing rural drainage lines.
- However, the time and labour costs of their installation makes them of questionable value for short-term construction disturbances.

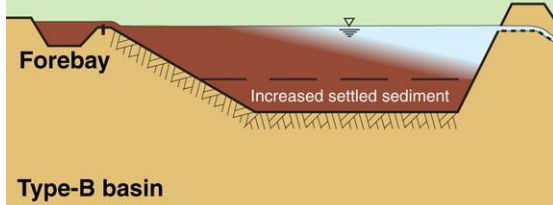
## Sediment basins (SB) – Type 1 sediment control

Basin overflows with settled supernatant spilling over main spillway



Low-flow decanting of a Type A basin

Basin overflows with settled supernatant spilling over main spillway



Overflow of a Type B basin



Type C sediment basin



Type D sediment basin

### Type A sediment basins

- A Type 1 sediment trap.
- Used on drainage catchments greater than 2500 m<sup>2</sup>.
- It is recommended that individual basins are limited to catchment areas less than 5 hectares.
- Used when the duration of the soil disturbance, within a given drainage catchment, exceeds 12 months.

### Type B sediment basins

- A Type 1 sediment trap.
- Used on drainage catchments greater than 2500 m<sup>2</sup>.
- Maximum recommended catchment area is 5 hectares.
- Used when the duration of the soil disturbance within a given drainage catchment does not exceed 12 months.
- Water can be retained in these basins for use on-site for revegetation watering and dust control.

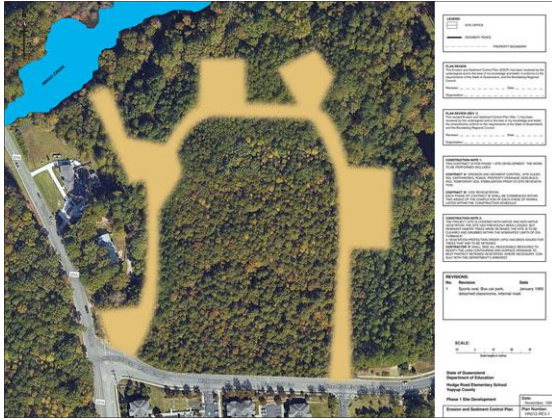
### Type C sediment basins

- Type C basins are used to treat the runoff from coarse-grained soils.
- These basins are free draining, which does not normally allow sufficient time for chemical flocculation, thus the sediment must have good settling properties.
- These are typically the smallest basins because of the fast settling properties of coarse-grained soils.
- Internal baffles may be needed to help control water flow through the basin.

### Use of Type D sediment basins

- Type D (dispersive soil) basins are best suited to fine-grained and/or dispersive soils.
- These basins retain inflows without free-draining, which allows time for chemical flocculation and particle settlement.
- These basins can be up to twice the size of Type C basins, but are significantly more effective at controlling turbidity.
- The development of Type A & B basins has effectively superseded the use of Type D basins.

## Step 12 – Review proposed staging of works



Initial site clearing

### Introduction

- This step in the development of an Erosion and Sediment Control Plan will not be relevant on all projects.
- The purpose of this step is to:
  - identify if there will be significant staging of earthworks
  - determine if a separate ESCP will be required for each stage of works
  - determine what sediment basins will need to be active during each stage of works.



Final site clearing

### Hodge Road Case Study site

- On the Case Study site, there will be only one stage of earthworks, which means all four sediment basins will need to be constructed prior to the start of earthworks.
- Initial site clearing should be restricted to those areas necessary to access and construct the sediment basins, site office compound, and stockpile areas.

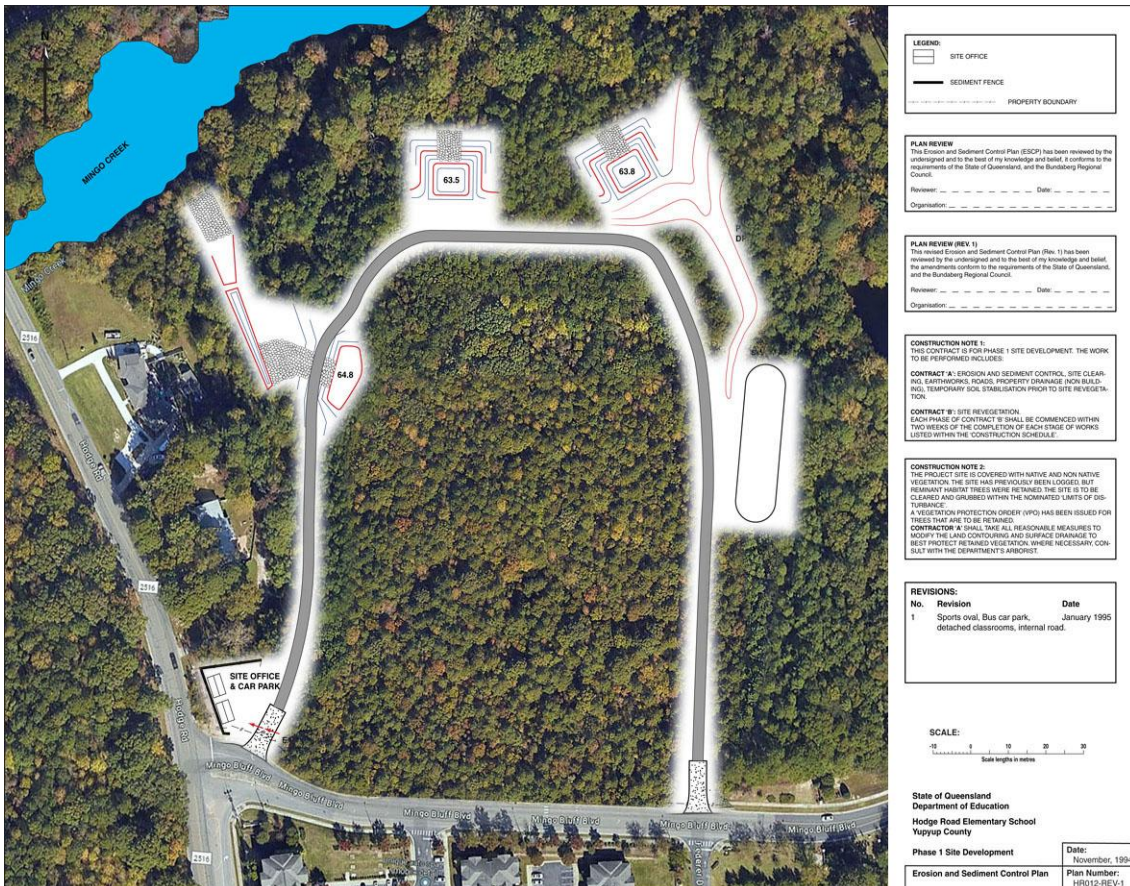


Figure 16 – Initial land clearing to allow construction of the sediment basins

## Step 13 – Control ‘clean’ water run-on and runoff



Photo supplied by Catchments & Creeks Pty Ltd

**Diversion of clean water through a site**

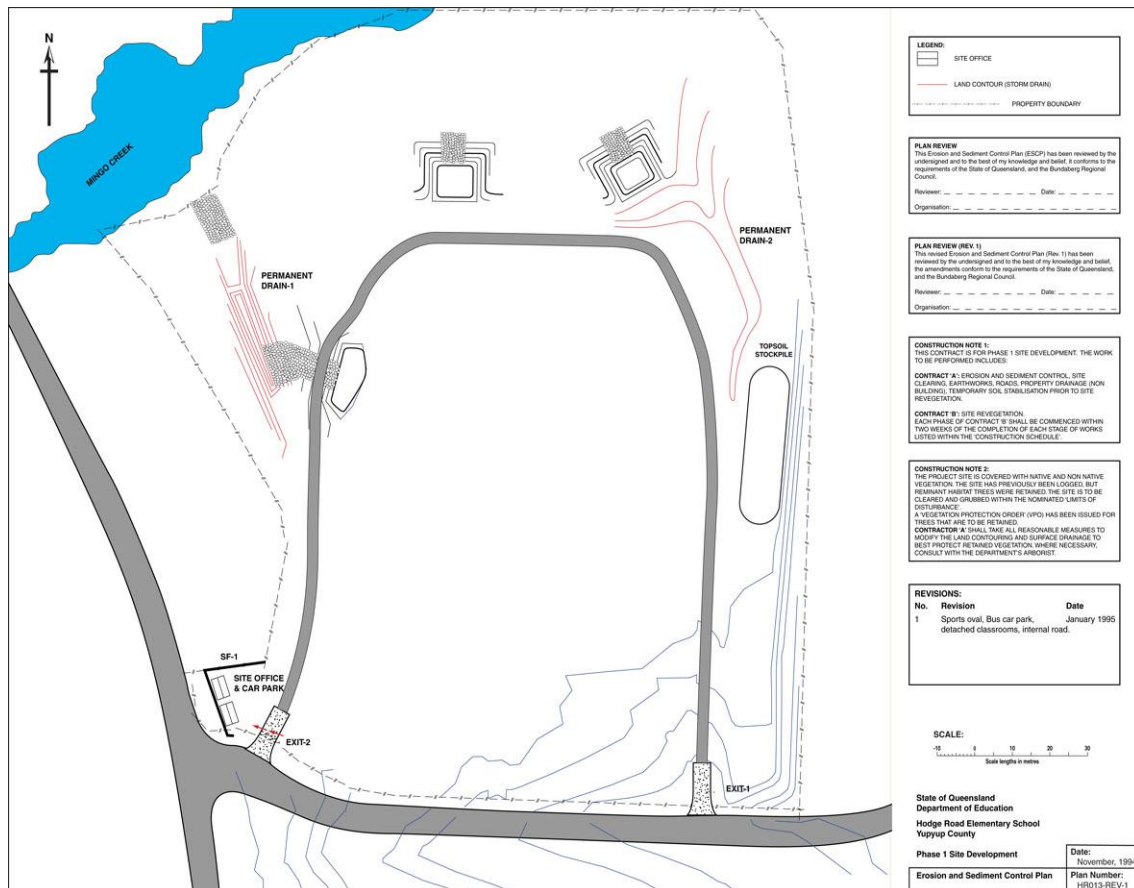


Photo supplied by Catchments & Creeks Pty Ltd

**Release of clean water into a drain**

### Introduction


- This step involves taking all reasonable and practicable measures to:
  - convey up-slope ‘clean’ **run-on water** around, or through, the work site (this stormwater from an up-slope property, and then runs onto your work site)
  - minimise the contamination of ‘clean’ water
  - divert ‘clean’ water away from sediment traps
  - divert ‘clean’ water away from site entry/exit points
  - separate the movement of ‘clean’ and ‘dirty’ water.
- The above mentioned run-on water is classified as ‘clean’ water because it was not made dirty on your work site; however, if the turbidity of this water increases as it passes through your site, then treating this water becomes your problem.
- **Case Study site:** There are two stormwater channels that will need to be constructed, Drain-1 and Drain-2, which will carry clean water and dirty water at different stages of the construction.



**Figure 17 – Clean water flow paths on the Hodge Road school site**

The following tables present the [suggested](#) identification codes and drawing symbols for various drainage control techniques. These codes and drawing symbols are not mandatory. Designers should simply choose drawing symbols that best display the intent of the Erosion and Sediment Control Plan.

**Table 6 – Drainage control techniques (not mandatory)**

Technique	Code	Symbol	Technique	Code	Symbol
Catch Drain	CD	→ CD →	Chute	CH	→ CH →
Diversion Channel	DC	→ DC →	Flow Diversion Bank	DB	→ DB →
Level Spreader	LS	LS ↓ ↓ ↓ ↓ ↓ ↓ ↓ ↓	Outlet Structure	OS	OS 
Recessed Rock Check Dam	RRC	→ RRC →	Rock Check Dam	RCD	→ RCD →
Sandbag Check Dam	SBC	→ SBC →	Slope Drain	SD	→ SD →
Temporary Bridge crossing	TBC	TBC ~   ~	Temporary Culvert crossing	TCC	TCC ~   ~
Temporary Downpipe	TD	TD ○ →	Ford	TFC	TFC ~   ~
Triangular Ditch Check	TDC	→ TDC →			

**Table 7 – Channel and chute linings (not mandatory)**

Technique	Code	Symbol	Technique	Code	Symbol
Cellular Confinement System	CCS	→ (CCS) →	Erosion Control Mat	ECM	→ (ECM) →
Geosynthetic Lining	GEO	→ (GEO) →	Grass Lining	GC	→ (GC) →
Grass Pavers	GP	→ (GP) →	Hard Armouring	HA	→ (HA) →
Rock Lining	RR	→ (RR) →	Rock Mattresses	RM	→ (RM) →
Turfing	T	→ (T) →	Turf Reinforcement Mat	TRM	→ (TRM) →

## Flow diversion techniques



Photo supplied by Catchments & Creeks Pty Ltd

**Catch drain used to divert run-on water**



Photo supplied by Catchments & Creeks Pty Ltd

**Large catch drain**



Photo supplied by Catchments & Creeks Pty Ltd

**Flow diversion bank**



Photo supplied by Catchments & Creeks Pty Ltd

**Mulch berm**

### Catch drains (CD)

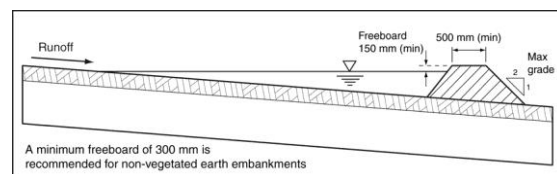
- Catch drains are used for the collection of sheet runoff, and the diversion of this runoff across a slope, or the diversion of the flow around a soil disturbance.
- They can also be used to collect 'dirty' water and carry it to a sediment trap.
- These drains are best used on erosion-resistant, non-dispersive soils.
- It is not advisable to cut a catch drain into a dispersive soil.

### Flow diversion channels (DC)

- Catch drains can be constructed with or without an adjoining down-slope bank.
- Larger catch drains (flow diversion channels) are usually formed by pushing the excavated soil down the slope to form both a drain and bank.
- Drains and channels can be earth-lined (low gradients only), or lined with erosion control mats, grass, or rocks.
- The application of any channel lining must not cause the drain's flow capacity to fall below its required design flow.

### Flow diversion banks (DB)

- Flow diversion banks are typically used instead of [Catch Drains](#) when the soils are dispersive, or otherwise highly erodible.
- They are usually formed from the stripped topsoil, which is unlikely to be dispersive.



### Sandbag or mulch berms (DB)

- Mulch berms can be used to divert either clean run-on water or site-generated dirty water.
- The mulch must be splintered (tub grinder), not 'chipped', in order to resist being washed away.
- Mulch berms are most commonly used when road works cut through existing bushland that can be mulched without contributing to the spread of weed seed.
- Mulch berms can also be used to filter sediment-laden sheet flow.

## Step 14 – Control erosion within all drains



Photo supplied by Catchments & Creeks Pty Ltd

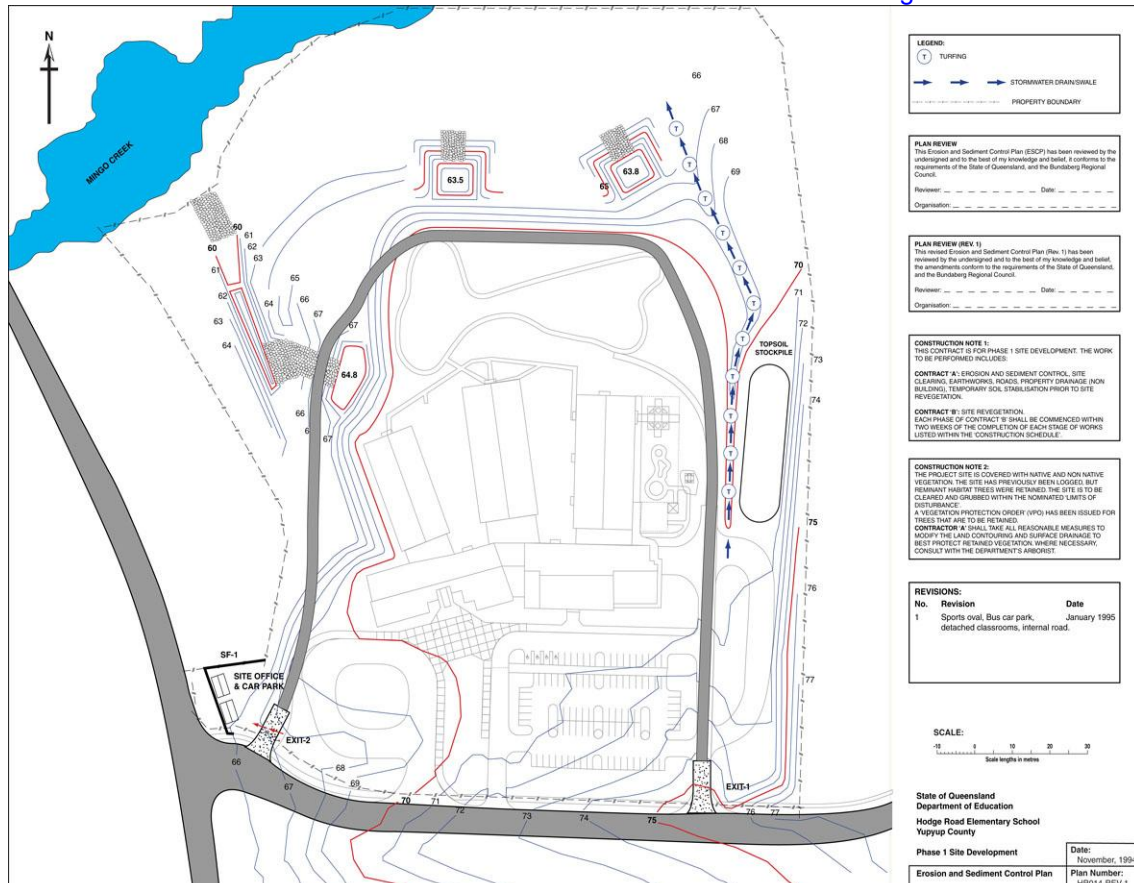
**Rock check dam**



**Erosion control mat (Hodge Rd, 1995)**

### Introduction

- All 'clean' water drains and flow diversions must be designed to operate at non-erosive flow velocities.
- The **flow velocity** can be reduced by:
  - reducing the depth of flow (i.e. increasing the width of the channel)
  - reducing the bed slope
  - reducing the peak discharge (i.e. reduce the effective drainage area), or
  - increasing the channel roughness.
- The effective **bed slope** of a channel can be reduced by:
  - reducing the bed gradient, or
  - introducing velocity-control **check dams**.
- The **erosion resistance** of a channel can be increased by:
  - compacting the soil
  - **turfing** the channel, or
  - the use of **erosion control mats**.
- **Case Study site:** The western drain will temporarily operate as Basin 2 (SB-2), and the eastern drain will be fully lined with turf. The western drain will eventually be converted into a vegetated swale.



**Figure 18 – Turfing of permanent stormwater channel on the Hodge Road school site**

## Velocity-control check dams



Photo supplied by Catchments & Creeks Pty Ltd

**Fibre rolls**



Photo supplied by Catchments & Creeks Pty Ltd

**Geo logs**



Photo supplied by Catchments & Creeks Pty Ltd

**Sandbag check dam**



Photo supplied by Catchments & Creeks Pty Ltd

**Rock check dam**

### General

- Check dams are most effective when used in channels with a gradient less than 10% (1 in 10); otherwise line the channel with turf, rock or erosion control mats.

### Fibre rolls (FCD)

- Fibre rolls consist of small-diameter (150–200 mm) biodegradable straw-filled logs.
- They can be used as check dams in wide, shallow drains so long as the logs can be anchored to prevent their movement.

### Geo log check dams (GCD)

- Geo logs have a larger diameter (approx 300 mm) compared to [Fibre Rolls](#).
- Geo logs made from coir (coconut fibres) can be very durable and last for a year or more (depending on the frequency of wetting and drying).
- It is very important to ensure that:
  - flows do not undermine the logs, and
  - flows spill **over** the logs, **not** around the ends of the logs.

### Sandbag check dams (SBC)

- Sandbag check dams are typically used in drains less than 500 mm deep, with a gradient less than 10% (1 in 10).
- These check dams are small (in height) and therefore are less likely to divert water out of the drain in comparison to [Rock Check Dams](#).
- The [biodegradable bags](#) are usually left in-place and allowed to integrate into the final drain vegetation—[synthetic bags](#) must eventually be removed from the drain.

### Rock check dams (RCD)

- Rock check dams should **only** be used in drains at least 500 mm deep, with a gradient less than 10%.
- They should only be used in locations where it is known that they will be removed once a suitable grass cover has been established within the drain.
- They can act as minor sediment traps.
- Rock check dams can be used as a permanent velocity-control device and/or sediment trap in earth-lined drains—check with the road authority.

## Channel and chute linings



Geotextile lined drainage chute



Jute mesh



Temporary erosion control mat



Turf reinforcement mat

### Geotextile linings (GEO)

- Geotextile linings are used to provide temporary scour protection in low to medium velocity drains.
- Heavy-duty filter cloth can be used to form temporary drainage [Chutes](#).
- Plastic sheeting can be used to form short, temporary drainage chutes down earth batters, but they must be used with caution—water flow must be prevented from passing under the plastic, especially if the underlying soil is dispersive.

### Jute and coir mesh (ECM)

- Jute or coir mesh is a form of [Erosion Control Mat](#), made from natural fibres, that can be used to provide temporary scour protection in low velocity drains.
- These products are generally preferred in natural environments and bushland areas.
- Erosion control and channel revegetation can be improved by:
  - placing the mesh over a [Mulch](#) layer, or
  - spraying the mats with an anionic bitumen emulsion or [Soil Binder](#).

### Erosion control mat (ECM)

- Some temporary erosion control mats contain an organic mulch reinforced with a synthetic mesh that will eventually break down under direct sunlight.
- Used to provide temporary scour protection in low & medium velocity drains.
- **Caution:** synthetic reinforced mats should **not** be used in bushland areas because ground dwelling animals, such as lizards, snakes, and granivorous (seed-eating) birds, can become entangled in the netting.

### Turf reinforcement mat (TRM)

- Turf reinforcement mats are used for the lining of high-velocity, permanent drains and chutes.
- Also used to line grassed *bywash* spillways on dams and [Sediment Basins](#).
- These permanent reinforced mats are usually distinguished from temporary mats by their dark colour, or the inclusion of a black synthetic reinforcing mesh—the black colour identifying the inclusion of UV-stabilising carbon.

## Channel and chute linings



**Turf lined diversion drain**



**Pre-grown reinforced grass**



**Cellular confinement system**



**Rock lining (RR)**

### Turfing (T)

- Turf can be used for the lining of low velocity [Chutes](#), [Catch Drains](#) and [Diversion Channels](#).
- If high velocity flows are likely within the first two weeks, then the turf should be anchored with wooden pegs.
- Metal staples (used to anchor [Erosion Control Blankets](#)) should **not** be used—a potential rust hazard for pedestrians.
- It is important to ensure that water entering the turfed area is not diverted along the upper edge of the turf.

### Reinforced grass (TRM)

- Pre-grown reinforced grass can be used for the lining of high-velocity, permanent drains and [Chutes](#).
- Also used to line grassed *bywash* spillways on dams and [Sediment Basins](#).
- Particular attention (i.e. placement and anchorage) should be given to the crest, toe, and sides of the mat during installation to avoid the potential for future erosion and/or uplifting.

### Cellular confinement system (CCS)

- Cellular confinement systems can be used to stabilise low to medium velocity [Chutes](#).
- The pockets may be filled with small rocks or vegetated (grassed) soil to form a temporary or permanent batter [Chute](#).
- These products can also be used to form temporary vehicle access across dry, sandy-bed streams.

### Rock lining (RR)

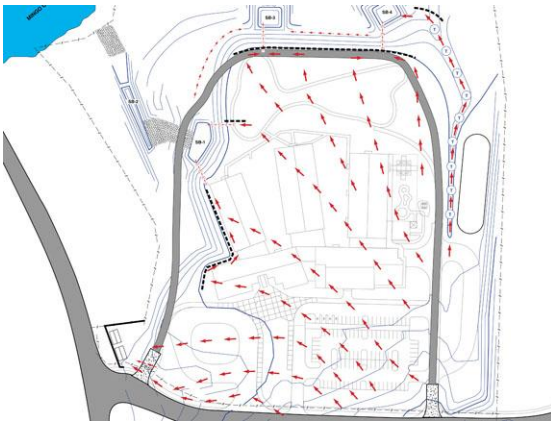
- Rock can be used for the lining of high-velocity, permanent drains and [Chutes](#).
- Also used to line spillways on dams and [Sediment Basins](#).
- An underlying geotextile or fine rock filter layer is generally required unless all the voids are filled with soil and vegetated.
- Note; rounded rock is significantly less stable than angular (fractured) rock.

## Step 15 – Control ‘dirty’ water runoff



Photo supplied by Catchments & Creeks Pty Ltd

Catch drain and table drain



Post-earthworks drainage plan

### Introduction

- It is usually necessary to have a ‘dirty’ water drain running along the lower edge of a soil disturbance in order to direct sediment-laden water to a sediment trap.
- However, drains located immediately adjacent to fill slopes are usually not effective due to the high risk of displaced fill material blocking the drain.
- The runoff from small areas of soil disturbance may be directed as sheet flow to a **Sediment Fence**, **Mulch Berm**, or **Compost Filter Berm**.
- Where appropriate, locate **Catch Drains** or **Flow Diversion Banks** at regular intervals down the exposed slopes to collect sediment-laden runoff before it is allowed to cause rill erosion.
- Drains located immediately up-slope of residential properties may need to be designed to a higher standard than other lower risk drains on the work site.
- The actual school site located in NC, USA, made extensive use of Slope Drains to direct ‘dirty’ water to the sediment basins.
- Slope Drains are not widely used in Australia due to their limited flow capacity.

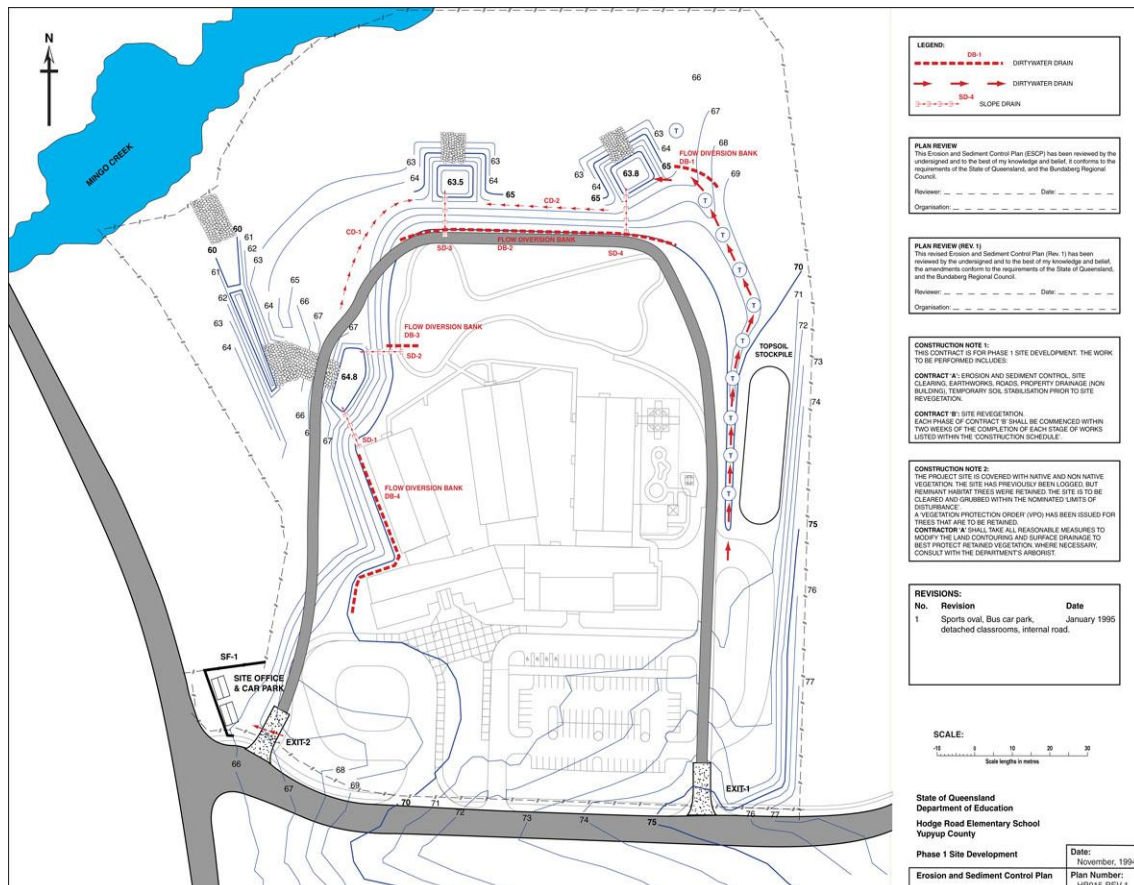


Figure 19 – Flow diversion systems directing ‘dirty’ water to sediment traps

## Hodge Road Elementary School (actual school site, 1995)



Slope drain (Hodge Road site, 1995)

### Flexible, reusable, solid-wall Slope Drains

- Slope drains are most commonly used in locations where stormwater runoff discharge is expected to be low (i.e. not exceed the inlet capacity of the pipe).
- Slope drains can also be used to direct concentrated flows through bushland with minimal disturbance occurring to the bushland.



Slope drain pipe entrance (1995)

### Flow control at pipe entry

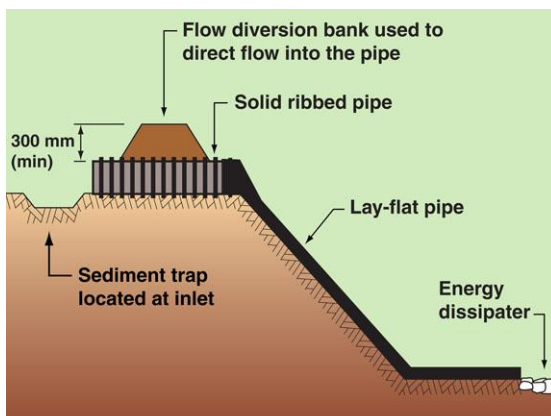
- A [Flow Diversion Bank](#) is required at the inlet of the slope drain to direct water into the pipe.
- Stabilisation at the pipe inlet may also be required to prevent scouring as the inlet.



Sediment trap outlet (1995)

### Sediment traps and energy dissipation

- Sediment traps can be incorporated into the inlet and/or outlet of these pipes.
- ALL slope drains require:
  - suitable [Flow Diversion Banks](#) at the pipe inlet to control flow entry
  - a means of preventing sediment blockage of the pipe's inlet
  - a stable outlet ([Outlet Structure](#)) at the end of the slope drain to control erosion.



Lay-flat pipe slope drain

### Lay-flat pipes

- Lay-flat pipes can be used as an alternative to solid-wall pipes.
- These drains can be an effective way of temporarily diverting water through a non-disturbance area, or an adjacent property, with minimal disturbance.

## Batter chutes (CH)



Photo supplied by Catchments & Creeks Pty Ltd

**Filter cloth lined batter chute**

### Filter cloth linings

- Geotextile cloth can be used to provide temporary scour protection in temporary, low to medium velocity diversion drains.
- Heavy-duty filter cloth can also be used to form temporary batter chutes.
- Filter cloth should **not** be used as a channel lining if the surface soils are dispersive—this is because severe rilling or tunnel erosion can occur under the fabric.



Photo supplied by Catchments & Creeks Pty Ltd

**Temporary plastic sheet batter chute**

### Impervious plastic sheeting

- Impervious sheeting can be used to form short, temporary drainage chutes down earth batters, but they must be used with caution—water flow must be prevented from passing under the plastic.
- Plastic sheeting can be used on dispersive soils, but with extreme care.



Photo supplied by Catchments & Creeks Pty Ltd

**Temporary half-pipe batter chute**

### Half-pipe slope drains

- Solid half-pipes can be used on unstable or dispersive soils.
- ALL chutes require:
  - berms to direct flow into the chute
  - a good water seal at the chute's inlet (note images below)
  - a well-defined cross-section to fully contain the flow down the chute
  - a stable outlet and energy dissipation system at the base of the chute.



Photo supplied by Catchments & Creeks Pty Ltd

**Corrugated iron batter chute**



Photo supplied by Catchments & Creeks Pty Ltd

**Concrete water seal at chute inlet**

## Step 16 – Control soil erosion on all disturbed areas



Photo supplied by Catchments & Creeks Pty Ltd

Application of straw mulch (1995)



Grass seeding with straw mulching (1995)

### Introduction

- The degree and timing of erosion control measures depends on the likelihood and intensity of expected winds and rainfall.
- If construction occurs during the dry season when moderate to heavy rainfall is unlikely to occur, then the degree of erosion protection is likely to be significantly less than if construction occurs during the wet season.
- A site revegetation (landscape) plan is not a substitute for appropriate erosion control measures identified on an ESCP.

### Hodge Road Case Study site

- This type of construction site allows the permanent stabilisation of earthworks shortly after the earthworks are finished.
- Areas around the school are to be:
  - turfed around buildings
  - seeded and straw mulching of playground areas
  - tube stock planting with heavy mulching of car park garden beds
  - native bushland regeneration of areas outside the active school zone.

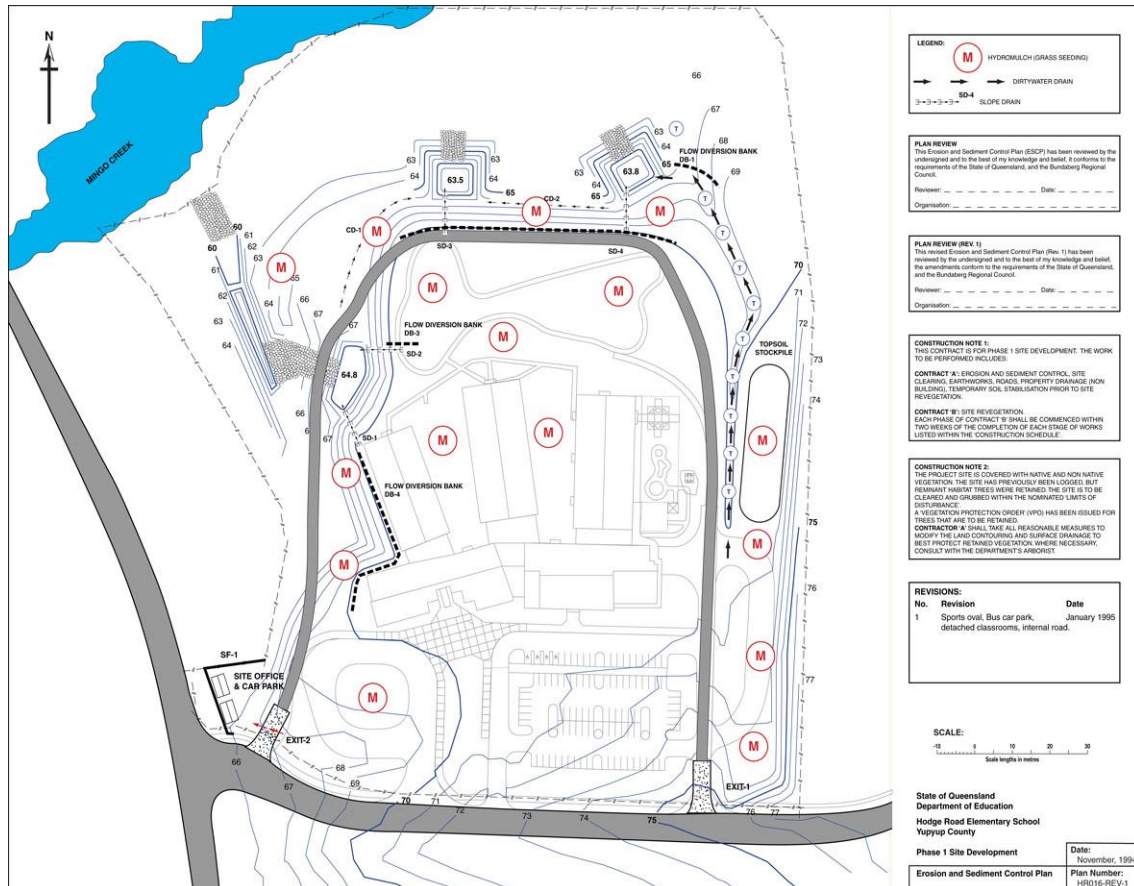






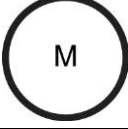
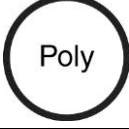
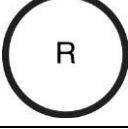
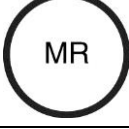




Figure 20 – Temporary erosion control measures on the Hodge Road school site

The following tables present the suggested identification codes and drawing symbols for various erosion control techniques. These codes and drawing symbols are not mandatory. Designers should simply choose drawing symbols that best display the intent of the Erosion and Sediment Control Plan.

**Table 8 – Erosion control techniques (not mandatory)**

Technique	Code	Symbol	Technique	Code	Symbol
<b>Bonded Fibre Matrix</b>	BFM		<b>Cellular Confinement System</b>	CCS	
<b>Compost Blanket</b>	CBT		<b>Erosion Control Blanket</b>	ECB	
<b>Gravelling</b>	Gravel		<b>Heavy Mulching</b>	MH	
<b>Light Mulching</b>	M		<b>Poly-acrylamide</b>	Poly or PAM	
<b>Revegetation</b>	R		<b>Rock Mulching</b>	MR	
<b>Soil Binders</b>	SBS		<b>Surface Roughening</b>	SR	

The appropriate application of erosion control products typically relates to the slope of the land and the expected shear stress resulting from stormwater runoff down the slope. The following table provides a general guide to the application of various erosion control measures.

**Table 9 – Typical application of erosion control measures to soil slopes**

Flat land (flatter than 1 in 10)	Mild slopes (1 in 10 – 1 in 4)	Steep slopes (steeper than 1 in 4)
Erosion Control Blankets	Bonded Fibre Matrix	Bonded Fibre Matrix
Gravelling	Compost Blankets	Cellular Confinement Systems
Mulching	Erosion Control Blankets, Mats and Mesh	Compost Blankets
Revegetation	Mulching well anchored	Erosion Control Blankets, Mats and Mesh
Rock Mulching	Revegetation	Revegetation
Soil Binder	Rock Mulching	Rock Armouring
Turfing	Turfing	Turfing

## Erosion control blankets (ECB)



**'Fine' jute blanket**



**'Thick' jute blanket**



**Jute mesh**



**Synthetic-reinforced blanket**

### Thin biodegradable blankets

- Organic-based blankets have low shear strength, and thus a low allowable flow velocity.
- **Fine blankets** are placed **over** seeded soil, while **thick blankets** can be used to temporarily suppress weed growth.
- Blanket placement requires:
  - good soil conditioning
  - good surface preparation, and
  - intimate contact between the blanket and the soil (i.e. no 'tenting').

### Thick biodegradable blankets

- Weed control features can be incorporated into some erosion control blankets.
- 'Thick' organic-based (jute) blankets can be used to suppress the establishment of weed seed contained within the original topsoil.
- Rather than placing these blankets over seeded soil, a seed/mulch mix is sprayed over the surface of the blanket, and the germinated seeds are allowed to root down through the blanket.

### Open mesh blankets

- A 'mesh' is an open weave blanket made from rope-like strands of hessian (jute), or coir (coconut fibre).
- **Jute mesh** has a design life in dry environments of around 3 to 12 months.
- **Coir mesh** has a design life in dry environments of around 12 to 24 months.
- In isolation, a mesh does not provide adequate protection against raindrop impact erosion.
- Meshes can also be used to anchor loose mulch, such as straw.

### Temporary synthetic-reinforced blankets

- Blankets with temporary synthetic mesh have a low to medium shear strength.
- These blankets typically have a design life of less than 12 months.
- The plastic mesh can represent a threat to wildlife, potentially entrapping animals such as lizards, snakes and birds.
- Synthetic-reinforced blankets should be used with **extreme caution** in or around bushland due to its potential hazard to wildlife, plus the release of micro-plastics.

## Temporary erosion control measures

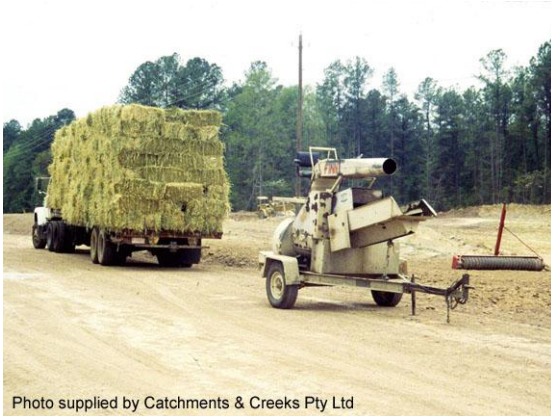


Photo supplied by Catchments & Creeks Pty Ltd

**Straw blower**

## Temporary erosion control measures

- Straw mulching is a common form of batter stabilisation as well as a component of batter revegetation.
- It is important to anchor the mulch so that it is not displaced by strong winds or stormwater runoff.
- Straw can be anchored with:
  - a light coating of anionic bitumen
  - mechanical crimping
  - jute mesh
  - wire mesh (long-term application).



Photo supplied by Catchments & Creeks Pty Ltd

**Temporary grass cover**



Photo supplied by Catchments & Creeks Pty Ltd

**Crimped straw mulch**



Photo supplied by Catchments & Creeks Pty Ltd

**Brushwood mulching**

## Batter stabilisation techniques

- Site-generated **brushwood** can be useful if the proposed batter revegetation consists mainly of hand-planted seedlings.
- Many different forms of **soil binders** exist, and most can be used for short-term batter stabilisation, but specialist advice is strongly recommended.
- **Erosion control blankets** can be applied in association with site revegetation, or as a separate process prior to site revegetation.



**Soil binder (e.g. Polyacrylamide)**



Photo supplied by Catchments & Creeks Pty Ltd

**Erosion control blankets**

## Step 17 – Establish sediment traps within the development



Drop inlet sediment trap (centre of image)



Mesh & aggregate drop inlet trap (1995)

### Introduction

- Identify opportunities for the placement of sediment traps within the development site.
- Wherever practical, sediment traps should be located as close to the sediment source as possible, without unnecessarily interfering with construction activities, or causing safety issues.
- It is noted that sediment traps must not cause a safety issue, particularly in public areas where people will not be familiar with the possible risks.

### Hodge Road Case Study site

- Other than the four sediment basins, the only sediment traps located within the work area (i.e. away from the outer boundary), are those associated with the numerous stormwater inlets of the permanent drainage network.
- Various kerb inlet and drop inlet sediment traps will be required on this site, and each device will need to be identified on the Erosion and Sediment Control Plan.

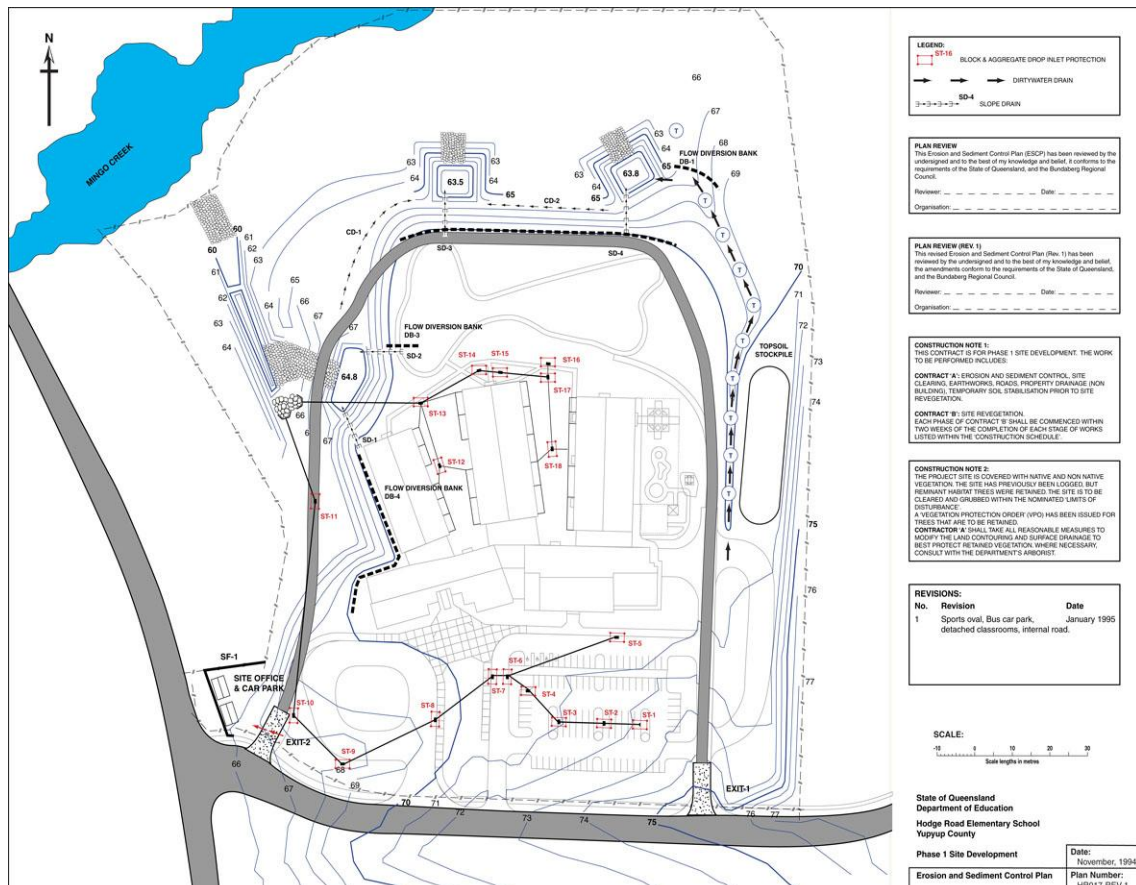


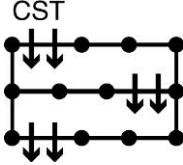

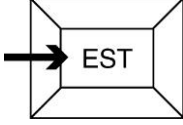




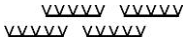


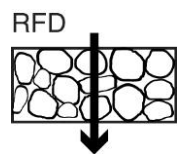
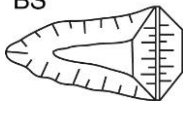
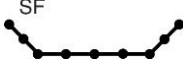
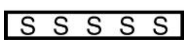
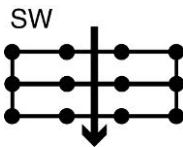


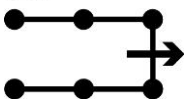


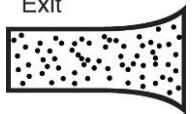
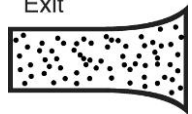
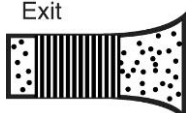
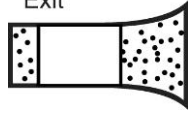
Figure 21 – Stormwater kerb and drop inlet sediment traps on the school site

The following tables present the suggested identification codes and drawing symbols for various sediment control techniques. These codes and drawing symbols are not mandatory. Designers should simply choose drawing symbols that best display the intent of the Erosion and Sediment Control Plan.



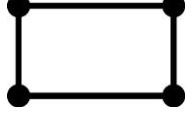
**Table 10 – Sediment control techniques (not mandatory)**

Technique	Code	Symbol	Technique	Code	Symbol
Buffer Zones	BZ		Check Dam Sediment Trap	CDT	CDT 
Coarse Sediment Trap	CST		Compost Berm	CB	
Excavated Sediment Trap	EST		Fibre Roll	FR	
Filter Fence	FF		Filter Sock	FS	
Filter Tube Dam	FTD		Grass Filter Strips	GFS	GFS 
Modular Sediment Trap	MST		Mulch Berm	MB	
Rock Filter Dam	RFD		Sediment Basin	SB	BS 
Sediment Fence – woven fabric	SF		Sediment Trench	SS	SS 
Sediment Weir	SW		Stiff Grass Barrier	SGB	
Straw Bale Barrier	SBB		U-Shaped Sediment Trap	UST	UST 

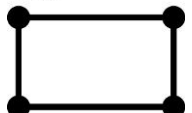
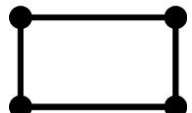

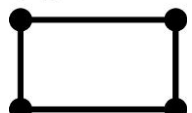
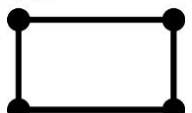
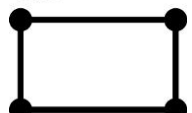
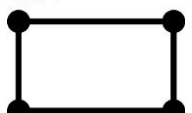
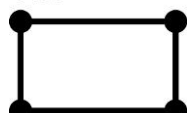
**Table 11 – Sediment control: entry/exit control techniques**

Technique	Code	Symbol	Technique	Code	Symbol
Construction Exit	Exit		Rock Pad	Exit	
Vibration Grid	Exit		Wash Bay	Exit	

**Table 12 – Sediment control: roadside kerb inlet control techniques**

Technique	Code	Symbol	Technique	Code	Symbol
Gully Bag	GB		On-grade Kerb Inlet Sediment Trap	OG	
Sag Inlet Sediment Trap	SA				

**Table 13 – Sediment control: field (drop) inlet control techniques**

Technique	Code	Symbol	Technique	Code	Symbol
Block & Aggregate Drop Inlet Protection	BA		Excavated Drop Inlet Protection	EX	
Fabric Drop Inlet Protection	FD		Fabric Wrap Inlet Protection	FW	
Filter Sock Drop Inlet Protection	FS		Gully Bag	GB	
Mesh & Aggregate Drop Inlet Protection	MA		Rock & Aggregate Drop Inlet Protection	RA	

## Kerb inlet sediment traps



Photo supplied by Catchments & Creeks Pty Ltd

**On-grade kerb inlet sediment trap**

### On-grade kerb inlet sediment traps (OG)

- On-grade inlets require a different sediment control system to 'sag' inlets.
- A series of sediment traps may be required to achieve optimum performance.

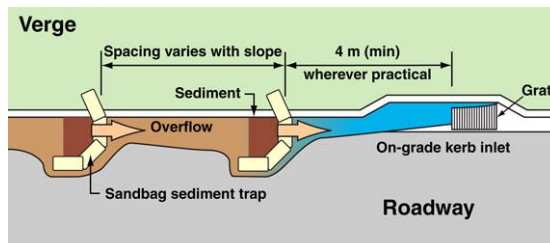


Photo supplied by Catchments & Creeks Pty Ltd

**Sandbag sediment trap**

### Installation of sandbag sediment traps

- Forming a 'spillway' helps to improve sedimentation by allowing sediment-laden water to pass through the small sediment pond rather than around it.

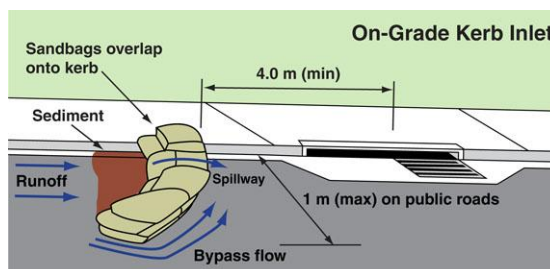


Photo supplied by Catchments & Creeks Pty Ltd

**Sag inlet sediment trap**

### Sag inlet sediment traps (SA)

- A supplementary sediment trap.
- Used as a minor sediment trap constructed around kerb inlets located at sag points along a roadway.
- As a general rule, the filter sock must not be allowed to fully block the kerb inlet. Exceptions apply only when:
  - there is no risk of causing flooding of adjacent properties; and
  - where there is a suitable flow bypass, such as a stable overland flow path.



Photo supplied by Catchments & Creeks Pty Ltd

**Gully bag**

### Gully bags (GB)

- A supplementary sediment trap.
- Commercial gully bags are generally considered to perform better than sediment traps placed on the road surface.
- They are typically used when it is considered unsafe to cause ponding or sediment deposition on the roadway.
- The types of gully traps include the flexible filter bags (left), and solid filter boxes lined with filter cloth.

## Drop inlet sediment traps



Photo supplied by Catchments & Creeks Pty Ltd

**Field inlet located within median strip**



Photo supplied by Catchments & Creeks Pty Ltd

**Fabric wrap inlet protection**



Photo supplied by Geofabrics Australasia

**Filter sock drop inlet protection**



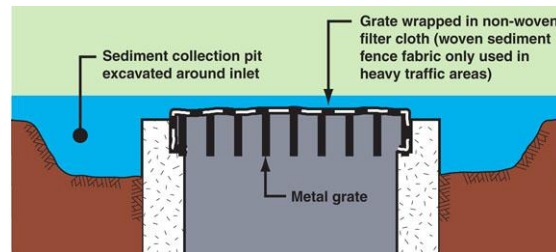
**Excavated drop inlet protection**

### Safety first

- Drop (field) inlet sediment traps are commonly used in the construction of dual-carriageways.
- The selection of the type of sediment trap depends on the following issues:
  - **safety issues**—do not use any sediment control system if that system represents a safety risk to persons or property
  - **flooding issues**—use of the sediment trap must not result in flooding of roadway or neighbouring properties.

### Fabric wrap inlet protection

- Suitable for very small catchment areas.
- Its use is uncommon in road construction.
- Formation of the excavated pit is critical.



### Filter sock drop inlet protection

- A **Type 3** sediment trap.
- Filter socks (including straw or compost-filled **Fibre Rolls**, and **Compost Berms**) are only suitable for small catchments.
- Socks filled with straw fibre are mostly suited to sandy soils.
- Compost berms and compost-filled socks work best in clayey soil areas.
- Compost-filled socks can adsorb some dissolved and fine particulate matter.

### Excavated drop inlet protection

- Excavated drop inlet protection is used in locations where water pooling around the stormwater inlet is not allowed to reach a level significantly higher than the existing ground level.
- These traps allow water to filter through aggregate and then drain through holes drilled through the inlet chamber walls.
- Safety issues may require the excavated pit to be surrounded by appropriate safety fencing.

## Drop inlet sediment traps

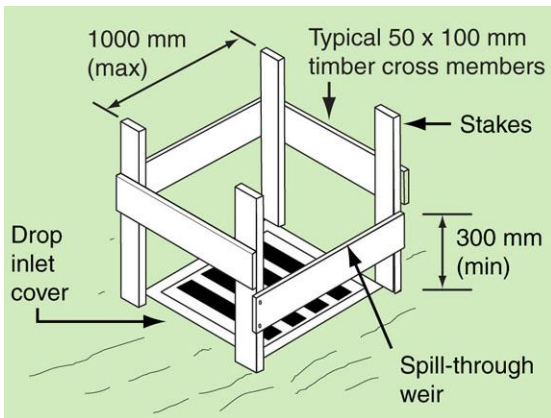


Photo supplied by Catchments & Creeks Pty Ltd

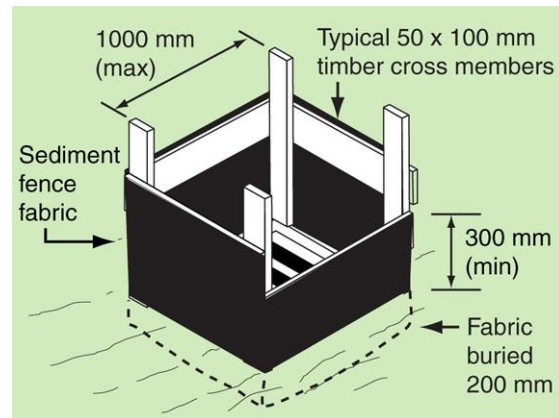
**Fabric drop inlet protection**

### Fabric drop inlet protection (FD)

- A [Type 3](#) sediment trap.
- Fabric drop inlet protection is best used on sandy soils.
- Suitable for relatively small catchment areas.
- Maximum spacing of support posts is 1 m (photo left is a poor example).
- A spill-through weir can be incorporated into one side of the sediment trap to control the depth of ponding.



**Installation of support frame**



**Placement of fabric**



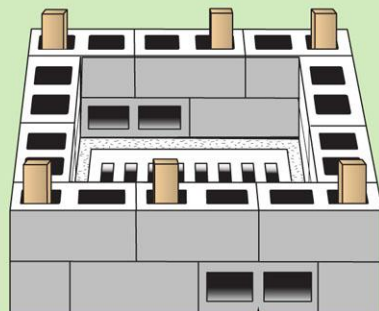
Photo supplied by Catchments & Creeks Pty Ltd

**Block & aggregate drop inlet protection**

### Block & aggregate inlet protection (BA)

- Block & aggregate drop inlet protection is suitable for small to medium catchments.
- In clayey soils, filter cloth is placed between the aggregate and blocks to improve the removal of fine sediments.
- The depth of ponding upstream of the drop inlet is governed by the height of the blocks.
- The diagrams below show two types of block arrangements (prior to placement of the aggregate).

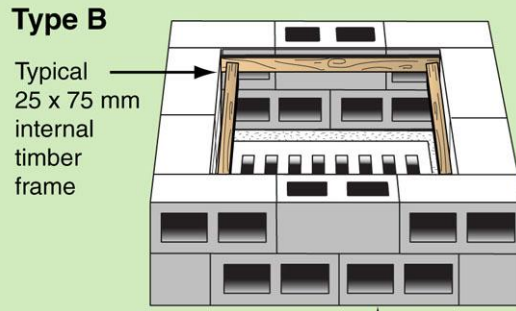
#### Type A



Maximum of one block turned sideways each side to allow for de-watering of the settling pond

**Block details for low flow rate system**

#### Type B



Maximum number of blocks on the bottom row turned sideways to maximise flow through the aggregate filter

**Block details for high flow rate system**

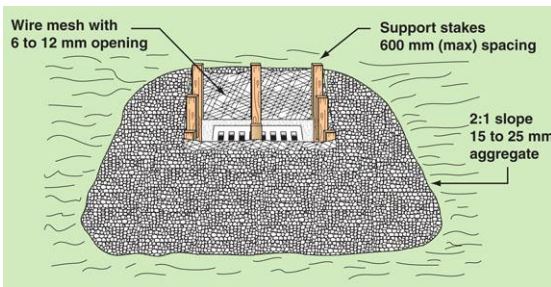
## Drop inlet sediment traps



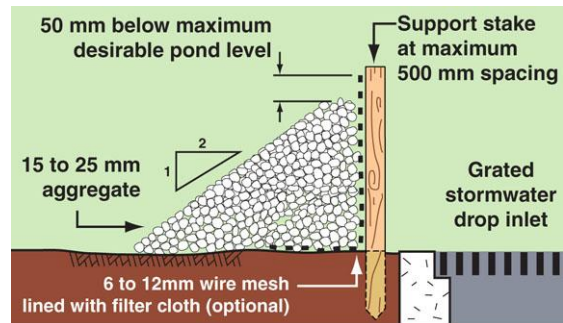
Mesh & aggregate drop inlet protection

### Mesh & aggregate inlet protection (MA)

- A [Type 2 or 3](#) sediment trap.
- Mesh & aggregate drop inlet protection is suitable for small to medium catchments.
- The depth of ponding upstream of the drop inlet is governed by the height of the aggregate filter placed around the wire mesh.
- In clayey soils, filter cloth may be placed over the aggregate to improve the removal of fine sediments (as per [Rock Filter Dams](#)).



Mesh & aggregate drop inlet protection



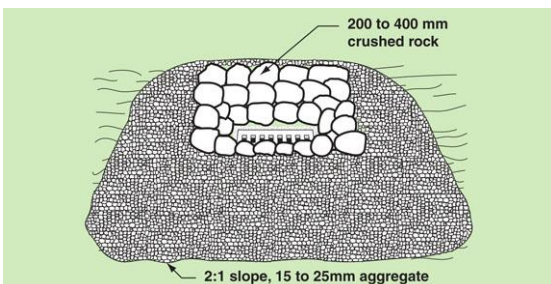
Construction detail



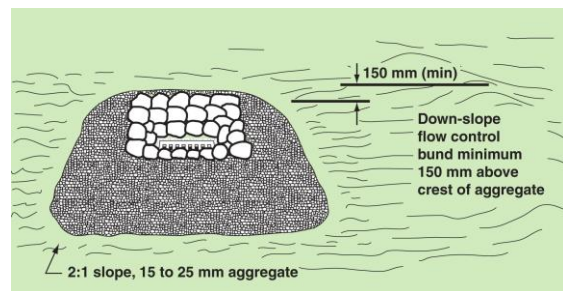
Rock & aggregate drop inlet protection

### Rock & aggregate inlet protection (RA)

- A [Type 2](#) sediment trap.
- Rock & aggregate drop inlet protection is best used in sandy soil areas.
- Most commonly used in highway construction such as a dual-carriageway road with the drop inlet located within the median strip.
- The critical design parameter is the surface area of the settling pond that forms around the protected drop inlet.
- [Flow Diversion Banks](#) may need to be incorporated into the sediment trap to control the depth and extent of ponding.
- Pooled water should not be allowed to spill onto trafficable lanes.



Rock & aggregate drop inlet protection



Flow diversion bank adjacent to drop inlet

**Drop inlet sediment traps – Hodge Road Elementary School**



**Figure 22 – Block & Aggregate Drop Inlet Protection (Hodge Road School, 1995)**



**Figure 23 – Block & Aggregate Drop Inlet Protection (Hodge Road School, 1995)**

## Sediment control techniques suitable for minor concentrated flow

The following table provides guidance on the selection of a sediment control technique suitable for placement within a table drain, minor channel or overland flow path.

**Table 14 – Sediment control technique for minor concentrated flows** <sup>[1]</sup>

	Sandbag check dam sediment trap	Rock check dam sediment trap	Coarse sediment trap	Excavated sediment trap	Filter tube dam	Modular sediment barrier	Stiff grass barrier	Straw bale barrier	U-shaped sediment trap
Standard drawing code	SBC	RC	CST	EST	FTD	MSB	SGB	SBB	UST
Typical treatment standard <sup>[2]</sup>	L	L	M	L	H	M-H	L	L	M
<b>TABLE DRAINS AND MINOR DRAINAGE CHANNELS – Less than 5% grade:</b>									
Channel depth < 500 mm	Yes			Yes					
Channel depth > 500 mm		Yes		Yes					
<b>TABLE DRAINS AND MINOR DRAINAGE CHANNELS – More than 5% grade:</b>									
Channel depth < 500 mm	Yes			Yes					Yes
Channel depth > 500 mm		Yes	Yes		Yes	Yes			Yes
Rural (long-term usage)							Yes		
<b>STORMWATER OUTLET SEDIMENT TRAPS:</b>									
Outlet fall < 300 mm				Yes					
Outlet fall > 300 mm			Yes		Yes	Yes			
Difficult access					Yes	Yes		Yes	
<b>OUTLET STRUCTURES FOR SEDIMENT FENCES:</b>									
Situations where the sediment fence is expected to produce concentrated outflows			Yes		Yes				

[1] Final selection should be based on actual site conditions.

[2] H = high treatment standard (e.g Type 2), M = medium treatment standard (e.g Type 3), L = low treatment standard (e.g. supplementary sediment trap).

## Sediment control techniques suitable for minor concentrated flow



Photo supplied by Catchments & Creeks Pty Ltd

**Check dam sediment trap**

### Check dam sediment traps (CDT)

- A [supplementary](#) sediment trap.
- Check dam sediment traps can be used to supplement the site's primary sediment control system.
- Typically used in table drains during the revegetation phase.
- The check dams may be constructed from rock, sand bags, or geo-logs.
- Check dams can operate as both drainage control and sediment control devices.



Photo supplied by Catchments & Creeks Pty Ltd

**Coarse sediment trap**

### Coarse sediment traps (CST)

- A [Type 3](#) sediment trap.
- Coarse sediment traps are best used on sandy soils.
- Commonly used as a sediment trap at the low point of a [Sediment Fence](#) placed on a medium-sized catchment, and on certain stormwater outlets.
- Requires a large area of flat land.



Photo supplied by Catchments & Creeks Pty Ltd

**Filter tube dam sediment trap**

### Filter tube dams (FTD)

- Filter tube dams are typically used to trap sediment in minor drainage lines.
- Normally placed down-slope of a [Type 3](#) sediment trap, which is used to reduce the deposition of coarse sediment at the filter tube inlet.
- Filter tubes can be integrated into a variety of [Type 2](#) and [Type 3](#) sediment traps (including [Rock Check Dams](#), [U-Shaped Sediment Traps](#), [Rock Filter Dams](#), and [Sediment Weirs](#)) to improve their efficiency during minor flows.



Photo supplied by Adam Pullen, Western Pipeline Alliance

**Modular sediment trap**

### Modular sediment traps (MST)

- A [Type 2](#) or [Type 3](#) sediment trap.
- Modular systems are the modern replacement for [Straw Bale Barriers](#).
- The filtration system is only capable of treating minor flows, but the units can be structurally sound in higher flows if adequately anchored in place.
- [Filter Tubes](#) can be incorporated into the plastic blocks to increase the allowable treatment flow rate.

## U-Shaped sediment traps (UST) – suitable for minor concentrated flow



Photo supplied by Catchments & Creeks Pty Ltd

**U-shaped sediment trap**



Photo supplied by Catchments & Creeks Pty Ltd

**U-shaped sediment trap in steep drain**



Photo supplied by Catchments & Creeks Pty Ltd

**Inappropriate installation**

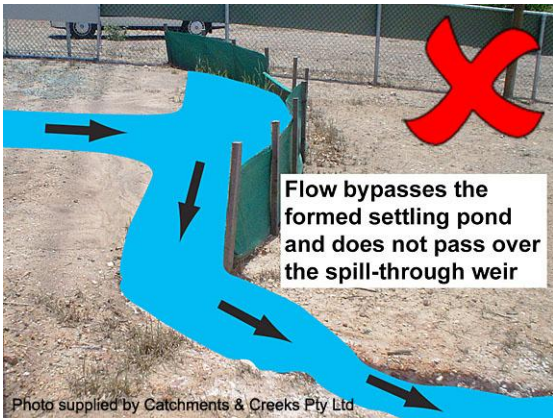


Photo supplied by Catchments & Creeks Pty Ltd

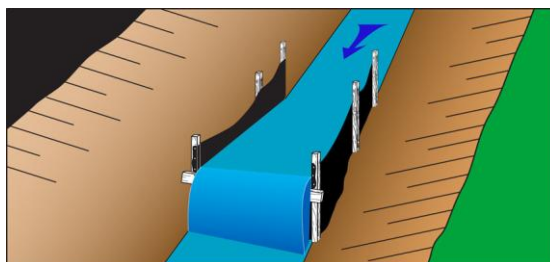
**Inappropriate installation**

### U-shaped sediment traps

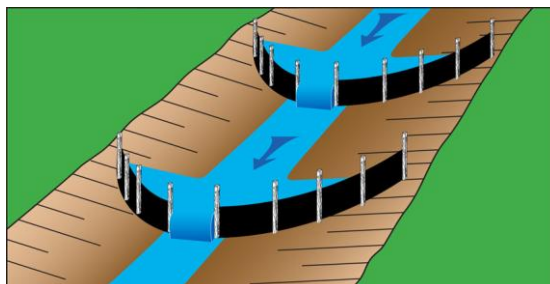
- A [Type 3](#) sediment trap.
- Typically used as coarse sediment traps within table drains on roads with a medium to steep gradient.
- The sediment trap **must** be constructed in a U-shape, **not** formed in a shallow arc, and **not** installed along a straight-line across the drain.
- A spill-through weir is usually required to prevent flows from bypassing around the sediment trap.
- The width of the sediment trap is usually determined by the width of the excavator bucket used to remove sediment.
- Filter tubes can be integrated into the trap (forming a [Filter Tube Dam](#)) to increase the trap's hydraulic capacity and to improve the treatment of low-flows.
- On low-gradient drains, preference should be given to the use of [Check Dam Sediment Traps](#).
- **Note:** spill-through weirs are only effective if the weir crest is at least 300 mm high, and the weir crest is below the height of the ground at the trap's inlet.

### Installation of U-shaped sediment traps

- A sediment trap must **not** be installed along a straight-line across the drain.
- The correct flow condition is shown below.



- A U-shaped sediment trap must not be formed in a 'shallow' arc across the drain as shown (left); however, if the drain is wide, a semi-circular shaped trap with spill-through weir can be used.



## Excavated sediment traps (EST) – Type 3 sediment trap

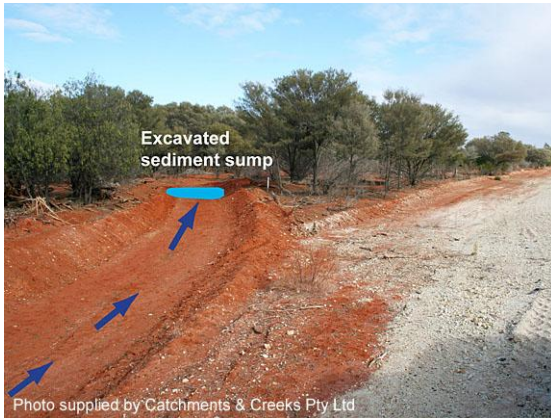


Photo supplied by Catchments & Creeks Pty Ltd

**Excavated sediment trap/sump**



Photo supplied by Catchments & Creeks Pty Ltd

**Excavated sediment trap**



Photo supplied by Catchments & Creeks Pty Ltd

**Excavated sediment sump**



Photo supplied by Catchments & Creeks Pty Ltd

**Sediment sump formed in dispersive soil**

### Excavated sediment trap

- A **Type 3** sediment trap.
- Unlike many urban projects, rural road construction often provides the opportunity to use a simple excavated pit as a sediment trap.
- Excavated sediment traps can come in several forms, but the simplest is just an excavated pit at the end of a diversion drain.

### Operation of an excavated sediment trap

- As flows pass over the excavated sediment trap, flow velocities slow, allowing coarse sediments to settle out.
- Site inspections must check that:
  - the sediment trap does not represent a safety risk
  - the side walls of the excavated pit are not subject to scour or slumping.

### Enhanced treatment

- Sediment capture can be enhanced through the incorporation of a **Type 2** sediment filter into the outlet of the sediment sump.
- Suitable **Type 2** filters include:
  - **Filter Tube Dams**, and
  - **Rock Filter Dams** lined with filter cloth.
- Rock filter dams with aggregate filters should not be used as outlet structures because the aggregate filter may never begin to function correctly.

### Complications caused by erodible soils

- Sediment sumps cannot be formed in highly erodible soils such as:
  - dispersive (sodic) soils
  - slaking soils, and
  - non-cohesive sandy soils.
- In the case of slaking or non-cohesive sandy soils, geotextile filter cloth can sometimes be used to stabilise inflow points.

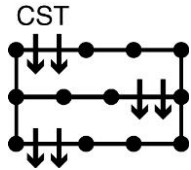
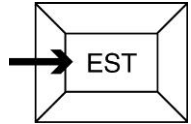


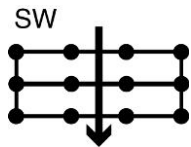

## Sediment control suitable for stormwater outlets

The following table outlines the attributes of **temporary** sediment control techniques that may be suitable for placement at stormwater outlets. Extreme care must be taken when selecting the preferred technique because not all of the techniques are suitable in all circumstances.

When locating a sediment trap at the outlet of a stormwater pipe, the sediment trap should ideally be located downstream of the influence of outlet 'jetting' (i.e. 10 pipe diameters downstream of the outlet). As a minimum, the sediment trap should be located at least 5 pipe diameters downstream of the outlet.

All sediment traps must be located totally within the relevant property boundaries unless otherwise approved in writing by the appropriate regulatory authority and landowner.

**Table 15 – Sediment control techniques at the outlet of stormwater pipes**

Technique	Code	Symbol	Typical use
<b>Coarse Sediment Trap</b>	CST		<ul style="list-style-type: none"> <li>Type 3 sediment trap.</li> <li>Best used on sandy soils.</li> <li>Only suitable if the outlet's invert is elevated at least 300 mm above the outlet channel.</li> </ul>
<b>Excavated Sediment Trap</b>	EST		<ul style="list-style-type: none"> <li>Supplementary sediment trap.</li> <li>Best used when it is necessary to avoid backwater ponding and thus sedimentation within the stormwater pipe.</li> <li>Safety issues may require the excavated pit to be surrounded by appropriate safety fencing.</li> </ul>
<b>Filter Tube Dam</b>	FTD		<ul style="list-style-type: none"> <li>Type 2 or 3 sediment trap.</li> <li>Only suitable if the outlet is elevated at least 300 to 500 mm above the outlet channel.</li> <li>It may not be practical to incorporate enough Filter Tubes to cater for the expected design flow rate. In such cases the sediment trap may only be considered a Type 3 system.</li> <li>A supplementary (coarse) sediment trap may be required upstream of the filter tubes to prevent sediment blockage of the filter tubes.</li> </ul>
<b>Modular Sediment Trap</b>	MST		<ul style="list-style-type: none"> <li>Type 3 sediment trap.</li> <li>Modern replacement for Straw Bale Barriers.</li> <li>Capability of accepting concentrated flows depends on construction technique.</li> </ul>
<b>Sediment Weir</b>	SW		<ul style="list-style-type: none"> <li>Type 2 sediment trap.</li> <li>Best used when high flow rates are expected.</li> <li>Filter Tubes can be incorporated into the Sediment Weir to improve the treatment of low-flows.</li> <li>Gabion walls can be used as an alternative to a Sediment Weir.</li> </ul>
<b>Straw Bale Barrier</b>	SBB		<ul style="list-style-type: none"> <li>Type 3 sediment trap.</li> <li>Only suitable when poor access for installation and maintenance prevents the use of other, more suitable, sediment traps.</li> </ul>

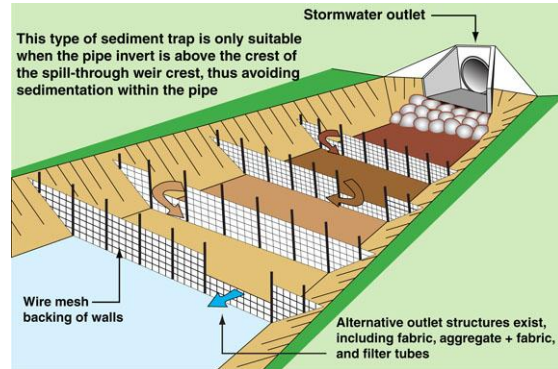
## Sediment control suitable for stormwater outlets



**Coarse sediment trap**

### Coarse sediment trap (CST)

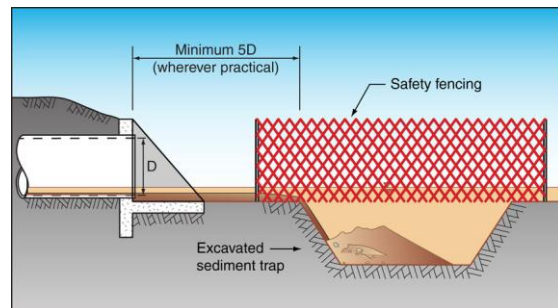
- Suitable for outlets with a low-fall outlet.



**Excavated sediment trap**

### Excavated sediment trap (EST)

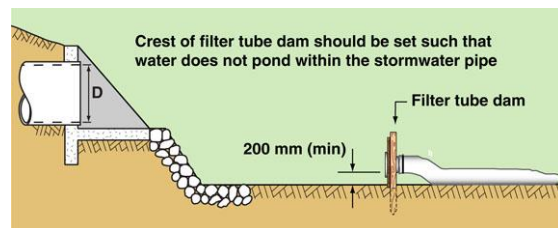
- Suitable for stormwater outlets with little or no fall at the outlet.



**Straw bale barrier**

### Straw bale barrier (SBB)

- **Warning:** straw bale barriers can be easily damaged by high-velocity outflows, and difficult to remove once waterlogged.
- Alternatives include [Filter Tube Dams](#).



**Inappropriate choice of sediment trap**

### Outlets with minimal outlet fall

- If the stormwater pipe discharges into an outlet channel with little or no fall, then any sediment trap with a crest level above the pipe invert (left) will pond water, and therefore settle sediment within the pipe.
- Such sediment traps can be very difficult to clean-out without releasing significant quantities of sediment downstream.
- An [Excavated Sediment Trap](#) is generally more suitable for such low-fall outlets.

## Step 18 – Control sediment runoff at the property boundary



Sediment on western boundary (1995)



Photo supplied by Catchments & Creeks Pty Ltd

Sediment fence (1995)

### Introduction

- At this point in the development of an ESCP it is a good idea to run your eye around the property boundary, or the limits of soil disturbance, and look for any location where sediment-laden runoff could leave the site untreated.
- In the past, some designers have become so focused on the design of the sediment basins that they have forgotten some of the smaller sub-catchments that drain directly to the street, or onto a neighbouring property.

### Hodge Road Case Study site

- On the Hodge Road site there is a region around the south-west corner where it is not 'convenient' to direct sediment-laden water to one of the sediment basins.
- Given the size of the sub-catchment, a Type-3 sediment trap, such as a 'sediment fence,' is considered sufficient.
- Ideally, most of this runoff would have been diverted to Sediment Basin SB-2 using a Flow Diversion Berm made for Tub-ground mulch generated from the tree clearing (not done in this case).

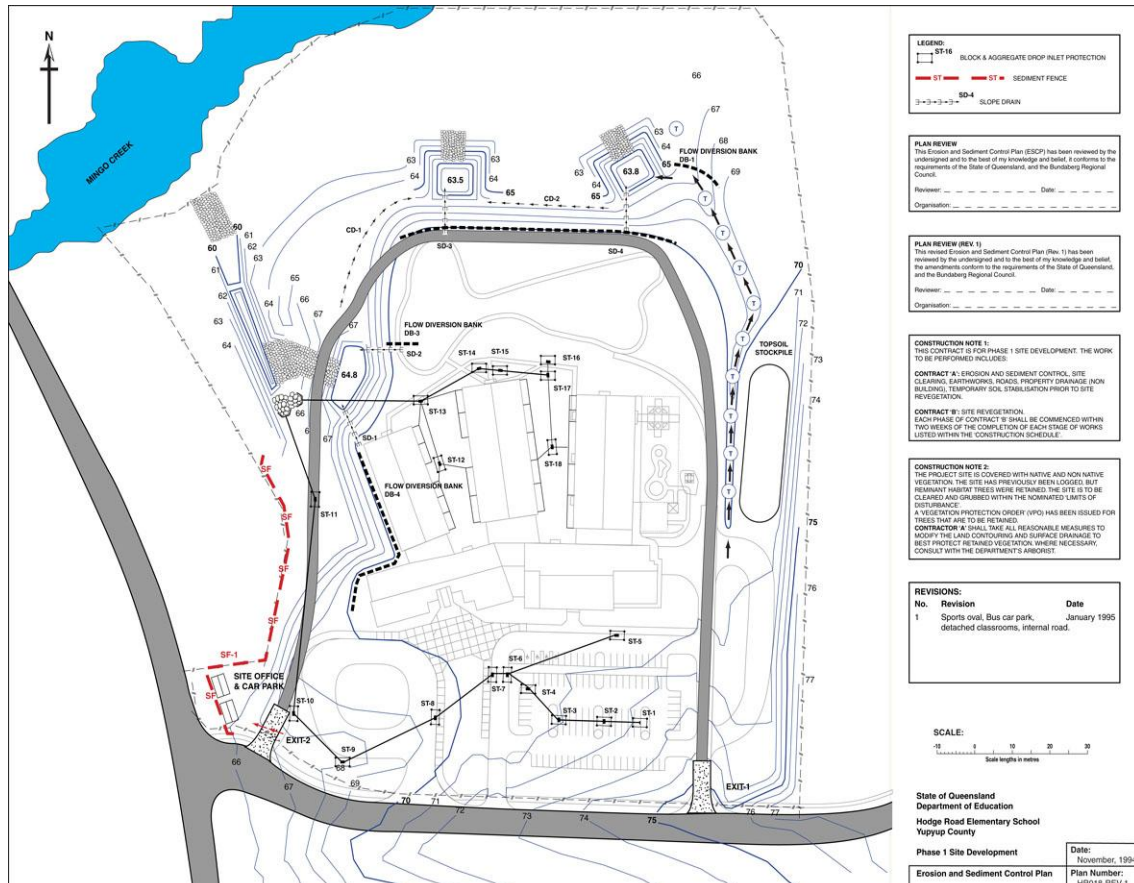
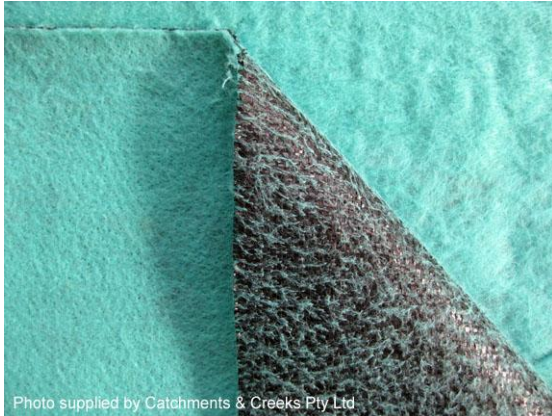
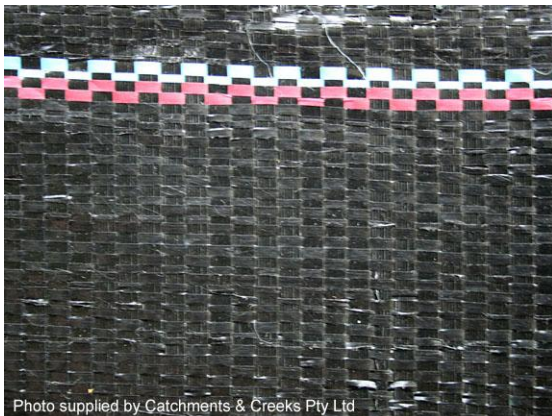


Figure 24 – Sediment controls placed along the limits of disturbance

## Use of geotextiles in sediment control



**Composite sediment fence fabric**



**Woven sediment fence fabric**



**Non-woven filter cloth**



**Filter sock**

### Use of geotextiles in sediment control

- Geotextiles can be used for a number of purposes, including:
  - slowing water flow to encourage ponding and gravity settlement
  - the filtration of dirty water
  - geotechnical engineering.
- Composite fabrics are sometimes used when it is desirable to perform more than one of the above tasks.
- Composite fabrics are not commercially available in all regions.

### Woven fabrics

- The primary purpose of a woven fabric is to **slow** the passage of water—these fabrics are **not** used for filtration.
- In most cases, the fabric is made from thin strips of impervious material; thus water can only weep through the small gaps where the fabric strips overlap.
- These fabrics are normally carbon stabilised (often producing the black colour) to reduce UV damage, thus extending their working life.

### Non-woven fabrics

- Non-woven fabrics are primarily used for filtration and geotechnical engineering.
- Most non-woven fabrics are not UV stabilised, thus they have a limited working life if exposed to direct sunlight.
- **Filter cloth** is the most common non-woven fabric found on construction sites.
- In Australia, filter cloth is commonly graded using the 'bidim' grading of A12 (thin) to A64 (thickest).

### Hessian fabric

- Hessian fabrics fall outside the normal rules because they are woven fabrics, but unlike most woven fabrics, they encourage filtration.
- Hessian fabrics can be used to form erosion control blankets, as well as hessian sandbags.
- Hessian sandbags can be filled with sand, aggregate, or compost to form a **Filter Berm**.

## The use of sediment fence 'returns'



Photo supplied by Catchments & Creeks Pty Ltd

### Placement of regular 'returns'

### Installation of 'returns' within a fence

- Sediment fences must incorporate regular 'returns', generally at a maximum 20 m spacing, but can be less as the slope along the fence increases.

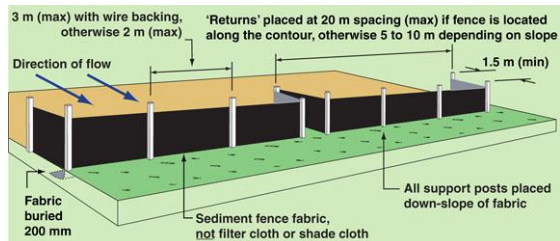


Photo supplied by Catchments & Creeks Pty Ltd

### Fence not returned up-slope at end

### Inappropriate installation techniques

- The ends of a sediment fence **must** be turned up the slope (known as a 'return') to prevent water simply passing around the end of the fence.

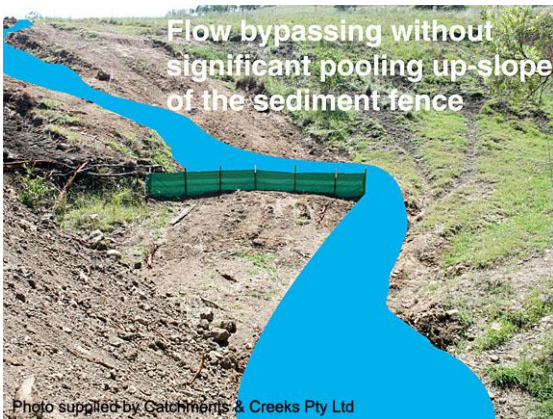


Photo supplied by Catchments & Creeks Pty Ltd

### Sediment fence fails to capture sediment

### Ability to capture and hold sediment

- A sediment trap should not just divert sediment-laden water from one location to another.
- When constructing a sediment trap, ask yourself:
  - Will the device cause a safety problem?
  - Where is the water going to flow?
  - Where is the sediment going to settle?
  - How will the trapped sediment be collected and removed?



Photo supplied by Catchments & Creeks Pty Ltd

### Stormwater runoff bypasses sediment trap

### Caution regarding the placement of sediment trap on steep slopes

- On steep slopes, say steeper than 10% (1 in 10), the focus should be **first** on controlling soil erosion, and **then** on controlling the flows down the slope.
- Wherever practical, the trapping of sediment should occur at the base of the slope, or at a location well away from the slope where it is safe and convenient to temporarily pond water (in this example, away from the pipeline trench and access track).

## Step 19 – Define the final limits of disturbance

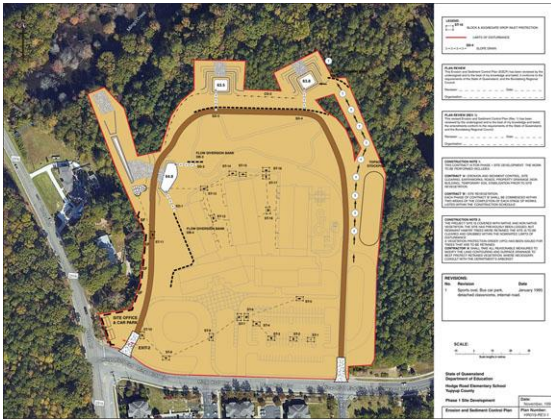


Photo supplied by Catchments & Creeks Pty Ltd

**Vegetation protection**

### Protection of retained vegetation

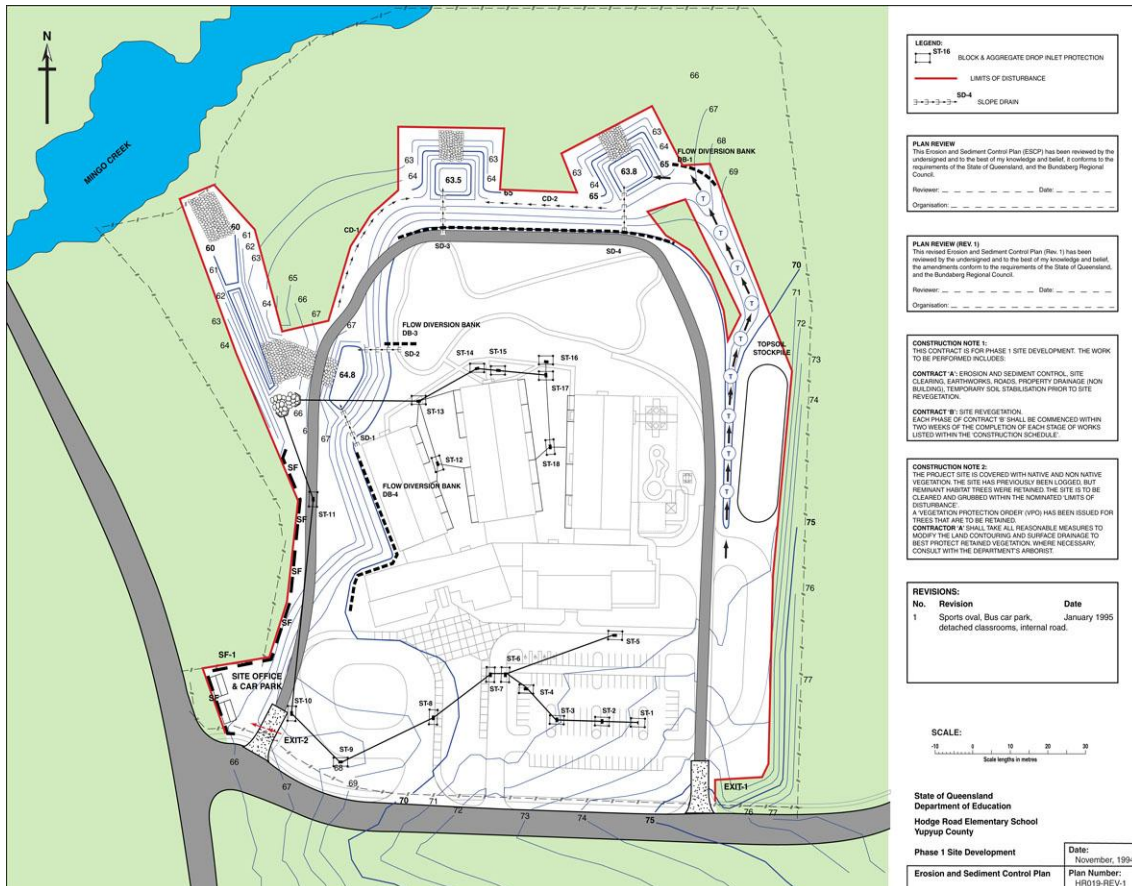
- At this point it should be possible to identify the final limits of disturbance.
- Where appropriate, prepare a **Vegetation Management Plan**, with instructions on the protection of retained vegetation.
- **Protection Zones** placed around trees should extend the greater of:
  - a minimum distance of 10 trunk diameters (measured 1 m from the ground), or
  - the width of the tree canopy.



**Final land clearing**

### Hodge Road Case Study site

- The limits of disturbance needs to extend into the riparian zone of Mingo Creek in order to construct a stable drainage channel suitable for concentrated flows.
- An alternative to this design would be to excavate a short side branch (tributary) into the bank of Mingo Creek, which would move the energy dissipater further away from the creek.
- This is a common design problem when natural 'sheet' flows are replaced by a concentrated drainage channel.



**Figure 25 – Limits of disturbance on the Hodge Road school site**

## Step 20 – Prepare the site revegetation/rehabilitation plan



Grass seeding with straw mulch (1995)



Grassing of sports oval (1995)

### Introduction

- Specify required site stabilisation, revegetation and rehabilitation measures.
- Typically it is not the job of an ESC specialist to prepare the Landscape Plan.
- However, the ESC specialist may be involved in determining how the planting will occur; for example:
  - grass seeding
  - hydromulching
  - compost blanket, or
  - turfing.

### Hodge Road Case Study site

- In the Case Study, site revegetation will consist of:
  - turfed around buildings
  - seeded and straw mulching of playground areas
  - tube stock planting with heavy mulching of car park garden beds
  - native bushland regeneration of areas outside the active school zone.

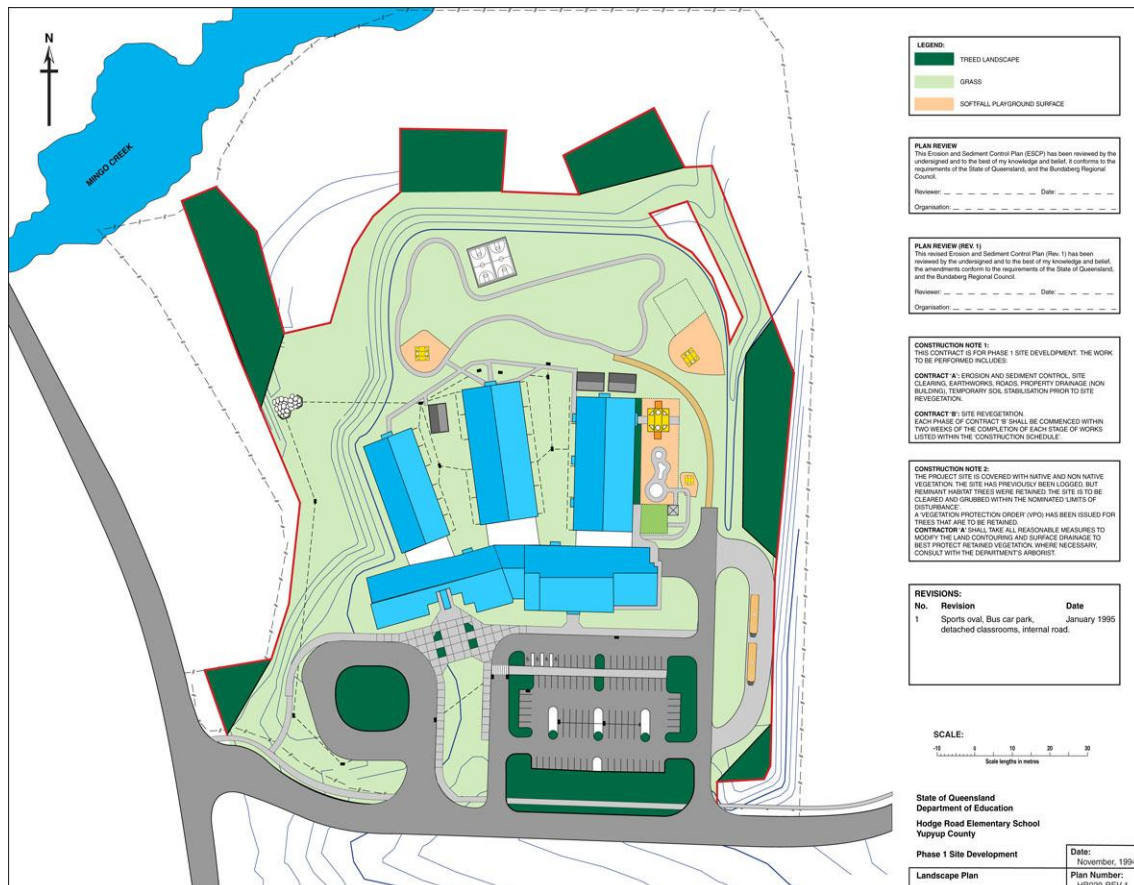


Figure 26 – Areas of grassing and bush regeneration on the Hodge Road school site

## Rehabilitation or reuse of sediment basins



Rehabilitated sediment basin SB-4 (2022)

### Hodge Road School, North Carolina

- The author is not aware of what steps were actually taken in 1995 to rehabilitate the sediment basins.
- Google images indicate that these areas were returned to native bushland.
- These days it is common for sediment basins to be converted into bio-retention basins as part of a site's permanent stormwater drainage network.
- However, on a school site it may not be desirable to have permanent open water ponds.



Photo supplied by Catchments & Creeks Pty Ltd

Stormwater treatment pond (2009)



Photo supplied by Catchments & Creeks Pty Ltd

Same pond (left) in 2017



Photo supplied by Catchments & Creeks Pty Ltd

Pollution containment pond (USA)

### Pollution containment basins

- Pollution containment basins function by 'containing' any pollutants released from traffic accidents, including fire-fighting chemicals.
- Any pollutants captured by the basins must be later removed for off-site treatment and disposal.



Photo supplied by Catchments & Creeks Pty Ltd

'Stop-board' outlet control system (SA)

### Outlet structures

- Pollution containment traps need to be fitted with outlet structures that will allow emergency services to isolate the basin to prevent the release of captured pollutants.
- Some agencies require such outlet structures to be fitted to a wide range of permanent stormwater treatment systems.

## Step 21 – Prepare the installation sequence



**Earthworks (1995)**

### Introduction

- On multi-stage construction sites, an [Installation Sequence](#) should be attached to the ESCP.
- The Installation Sequence identifies the expected order that ESC measures are installed and then decommissioned.
- Identifying each ESC item with a unique code (e.g. Exit-1, SF-1, SB-1, etc.) makes the task of preparing an Installation Sequence much easier.



**Building fabrication (1995)**

### Installation Sequence

- The Installation Sequence should provide the following information:
  - unique identification number/code
  - plan number where the control measure can be found
  - description of when the control measure is to be installed relative to other construction activities or ESC installations
  - description of when the control measure is to be decommissioned relative to other construction activities.

**Table 16 – Example ESC Installation Sequence (not the Case Study site)**

Code	Item	Plan	Installed	Removed
Mark out initial limits of disturbance				
Exit-1	Construction Exit	DWG-001	Day one	When permanent internal roads are sealed
Exit-2	Construction Exit	DWG-001	Day one	When permanent internal roads are sealed
Site office		DWG-010	Day one	End of works
SF-1	Sediment Fence	DWG-001	Prior to land clearing	After site stabilisation
SF-2	Sediment Fence	DWG-001	Prior to land clearing	After site stabilisation
SB-1	Sediment Basin	DWG-002	After SF-3	After site stabilisation
CH-1	Chute	DWG-002	During construction of SB-1	During removal of SB-1
Clearing of the basin's settling zone				
CD-1	Catch Drain	DWG-003	After construction of SB-1	After site stabilisation
SS-1	Sediment Trench	DWG-003	Prior to land clearing	After site stabilisation
CD-2	Catch Drain	DWG-003	After construction of SS-1	
CD-3	Catch Drain	DWG-003	After construction of SS-1	
SF-3	Sediment Fence	DWG-003	After land clearing	After site stabilisation

Alternatively, a [Construction Sequence](#) can be prepared that lists the timing of ESC measures relative to the various construction activities (example provided below).

**Table 17 – Example Construction Sequence (not the Case Study site)**

Code	Item	Plan	Installed	Removed
Development approval				
Appoint Safety Officer and ESC Officer				
Order Stage 1 erosion and sediment control supplies				
Pre-construction conference				
Mark out initial limits of disturbance				
Exit-1	Construction Exit	DWG-001	Day one	When permanent internal roads are sealed
Exit-2	Construction Exit	DWG-001	Day one	When permanent internal roads are sealed
Delivery and set-up site office		DWG-010	Day one	End of works
Delivery of waste bins				
SF-1	Sediment Fence	DWG-001	Prior to land clearing	After site stabilisation
SF-2	Sediment Fence	DWG-001	Prior to land clearing	After site stabilisation
SB-1	Sediment Basin	DWG-002	After SF-3	After site stabilisation
CH-1	Chute	DWG-002	During construction of SB-1	During removal of SB-1
Clearing of the basin's settling zone				
CD-1	Catch Drain	DWG-003	After construction of SB-1	After site stabilisation
SS-1	Sediment Trench	DWG-003	Prior to land clearing	After site stabilisation
CD-2	Catch Drain	DWG-003	After construction of SS-1	
CD-3	Catch Drain	DWG-003	After construction of SS-1	
Mark out stockpile area		DWG-003		
SF-3	Sediment Fence	DWG-003	After land clearing	After site stabilisation
Temporary sediment controls at property boundary on Road 2				
Clear and grub Roads 1 & 2		DWG-004		
Construction Roads 1 & 2		DWG-004		
Drainage Road 2		DWG-004		
Sediment controls Road 2 converted to "On-Grade" sandbag sediment trap				
Drainage Road 1		DWG-004		
All kerb inlets on Road 1 blocked to prevent sediment inflow				
Limited clearing of lots		DWG-005		
Construct drainage line 3		DWG-006		
Site revegetation		DWG-007		
Installation of temporary sediment controls down-slope of Sediment Basin prior to removal				
Removal of Sediment Basin				
Stabilisation of basin area		DWG-007		
Removal of site office				

## Step 22 – Specify emergency ESC measures



Photo supplied by Catchments & Creeks Pty Ltd

Approaching storm

### Being prepared for storms

- Construction sites need to be appropriately prepared for potential wet weather conditions.
- Only in those regions where extended periods of dry weather can be anticipated with high certainty can erosion and sediment control measures be reduced to a minimum.
- Tropical regions should have a declared wet season period during which ESC measures must be enhanced.

Table 18 – Overview of critical ESC measures for various weather conditions

Expected weather conditions	Likely critical aspects of erosion and sediment control
No rainfall or strong winds expected	<ul style="list-style-type: none"> <li>• If favourable dry-weather conditions are likely to exist with a reasonable degree of certainty, then avoid unnecessary expenditure on excessive ESC measures (<a href="#">based on expert advice</a>); however, always ensure the site is appropriately prepared for possible, unseasonable weather conditions.</li> <li>• It should be noted that effective sediment controls at site entry/exit points are generally always required, even during dry-weather conditions.</li> </ul>
Light rainfall	<ul style="list-style-type: none"> <li>• In general, the lighter the rainfall, the higher the desired quality of the water discharged from the site (mg/L &amp; turbidity-NTU).</li> <li>• Wherever practical, sediment control measures should be designed to maximise the <a href="#">‘filtration’</a> of sediment-laden water during periods of light rainfall, rather than gravity-induced sedimentation.</li> <li>• If a site discharges to a minor watercourse, then the release of sediment-laden water during periods of light rainfall can potentially cause more environmental harm than if the same quantity of sediment were released during moderate to heavy rainfall.</li> </ul>
Moderate to heavy rainfall	<ul style="list-style-type: none"> <li>• It is critical to ensure effective <a href="#">drainage control measures</a> exist on the site to prevent the formation of rill and gully erosion.</li> <li>• It is critical to ensure that sediment traps have an effective flow bypass system to prevent structural failure of the sediment trap.</li> <li>• Wherever practical, sediment control measures should be designed to maximise the <a href="#">gravity-induced settlement</a> of sediment-laden waters during periods of moderate to heavy rainfall.</li> <li>• Sediment control measures that rely on ‘filtration’ processes (i.e. filtration through a geotextile cloth) often experience severe blockage during heavy storms causing flow bypass.</li> </ul>
Strong winds	<ul style="list-style-type: none"> <li>• Ensure erosion control measures are appropriately anchored.</li> <li>• Maintain exposed clayey soils in a roughened condition to reduce dust generation (surface roughness reduces wind speed immediately adjacent the ground).</li> <li>• Assess the benefits of chemical-based soil stabilisers (<a href="#">Soil Binders</a>) instead of just using water trucks.</li> </ul>

## Preparing a site for an imminent storm



Photo supplied by Catchments & Creeks Pty Ltd

**Temporary flow diversion berm**

### Establish temporary flow diversions

- Form temporary berms up-slope of newly formed earth batters to:
  - direct runoff to [Slope Drains](#) or batter [Chutes](#)
  - prevent [Mulch](#) and seed from being washed from newly-seeded batters
  - minimise the risk of bank scour and slumping.
- Temporary [Flow Diversion Berms](#) can be formed from sandbags, topsoil, straw bales, [Geo Logs](#), or tub-ground [Mulch](#).



Photo supplied by Catchments & Creeks Pty Ltd

**Filter cloth anchored with timber stakes**

### Stabilise all drainage pathways

- If not already stabilised, line any steep or unstable drainage lines, including batter [Chutes](#), with well-secured geotextile cloth.
- Ensure that channel linings are anchored in accordance with the soil conditions, e.g. wire staples for stiff clay soils, barbed pins for loose soil, and timber stakes for loose or sandy soils.
- **Note:** metal staples may not provide immediate anchorage because the rusting process, which enhances anchorage of metal staples, has not yet occurred.



Photo supplied by Catchments & Creeks Pty Ltd

**Blankets displaced by wind**

### Secure erosion control blankets

- If strong winds are expected (common with storms), then additional anchorage may be required on [Erosion Control Blankets](#) if the following conditions exist:
  - the blankets have been anchored only with metal staples
  - insufficient rain has occurred to cause the staples/pins to rust
  - the soil is loose to firm, but not hard.
- Woody debris, sandbags, rocks, and stakes can provide additional anchorage.

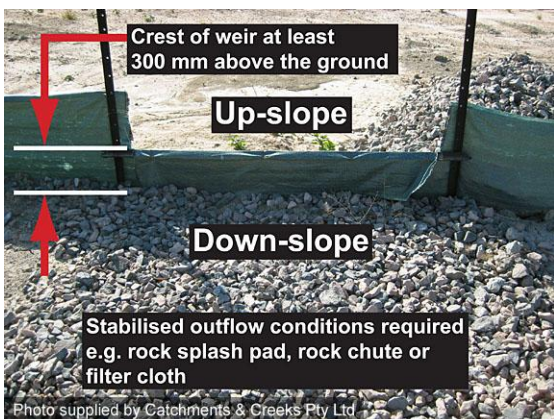


Photo supplied by Catchments & Creeks Pty Ltd

**Sediment fence with spill-through weir**

### Stabilise spill-through or bypass points

- Some storms can exceed the design conditions of the ESC Plan; however, this does not mean that sediment control measures should be allowed to fail.
- Spill-through weirs should be incorporated into sediment traps if such measures are required to allow flow bypassing, and prevent structural damage to the trap.
- There are many examples of poorly built spill-through weirs, so think carefully about the desired water flow when designing and building a flow bypass system.

## Step 23 – Prepare the Monitoring and Maintenance Program



Photo supplied by Catchments & Creeks Pty Ltd

**Storm undermines a sediment fence**

### Regular site inspections

- All erosion and sediment control measures should be inspected:
  - at least daily when rain is occurring (when it is safe to do so)
  - at least weekly (even if work is not occurring on-site)
  - within 24 hours prior to expected rainfall
  - within 18 hours of a rainfall event of sufficient intensity to cause runoff.
- **Don't wait for the next storm before checking that all ESC devices are working.**



Photo supplied by Catchments & Creeks Pty Ltd

**Upstream & downstream water samples**

### Collection of water samples

- Site inspections need to be conducted during both dry and wet weather.
- On large construction sites, third-party site inspections should occur.
- On large or high-risk sites, monitoring is likely to include specific water quality sampling, analysis, and detailed logbook entries of the site's monitoring and maintenance activities.

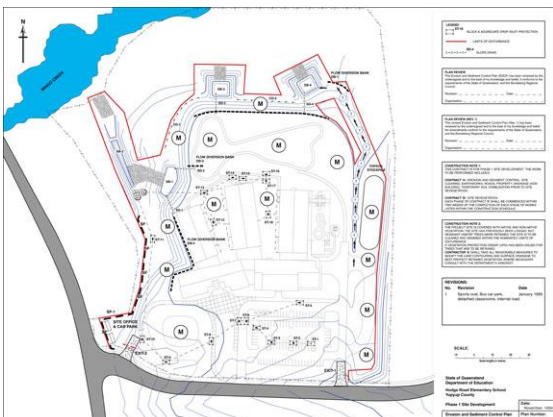


Photo supplied by Catchments & Creeks Pty Ltd

**Sediment deposited off the site**

### Investigate the source of sediment runoff

- When a site inspection detects a notable failure in the adopted ESC measures, the source of this failure must be investigated, and appropriate amendments made to the site to prevent a re-occurrence.
- If the site inspection identifies the need for a revised ESCP, then while this plan is being prepared, site personnel should take appropriate steps to minimise the risk of environmental harm.
- Waiting for a revised plan is not a valid reason for delaying reasonable actions.



**Erosion and Sediment Control Plan**

### Responding to poor test results

- Erosion and Sediment Control Plans (ESCPs) are living documents that can and should be modified if:
  - site conditions change, or
  - the adopted measures fail to achieve the required treatment standard (e.g. the water quality objectives).

## Step 24 – Prepare Inspection and Test Plans (ITPs)



Photo supplied by Catchments & Creeks Pty Ltd

**Poor grass cover**

### Introduction

- Inspection and Test Plans are usually prepared for:
  - revegetation contracts (most common)
  - larger construction works, typically larger than 1 hectare
  - sites where there is the need to control specific aspects of the construction process
  - where there are potentially high environmental impacts associated with the execution of the works.



Photo supplied by Catchments & Creeks Pty Ltd

**Inspection of root establishment**

### Use of Inspection and Test Plans

- It is uncommon for Inspection and Test Plans to be attached to Erosion and Sediment Control Plans.
- Their use should be assessed on a case-by-case basis.
- Large organisations would normally have key outcome requirements inserted into their standard revegetation contracts, or Environmental Management System.
- In earthworks contracts, **Hold Points** and **Witness Points** may be specified at key inspection points.

### INSPECTION AND TEST PLAN (Example – Revegetation)

Area Reference: \_\_\_\_\_ Sheet Number: \_\_\_\_\_ Location Description: \_\_\_\_\_

Construction Activity	Specification Description	Testing Standard	Product / Service Responsibility	Person Responsible	Testing Frequency	Test Result (Pass/Fail)	Hold Point (Yes/No)	Date
Water quality	Water quality test	Code XX.XXX	Earthmoving contractor	John Citizen	1 per water source		No	
Surface preparation	Prepared to specification	Code XX.XXX	Earthmoving contractor	Operator	Each area		Yes	
	Watered at 5L/m <sup>2</sup>	Code XX.XXX	Earthmoving contractor	Operator	Each area		Yes	
Hydromulch	Certificate of seed analysis	Code XX.XXX	Revegetation contractor	Operator	Each load		No	
	Mulch	Code XX.XXX	Revegetation contractor	Operator	Each load		No	
	Application of mulch	Code XX.XXX	Revegetation contractor	Operator	Each load		No	
Completion	Instruction memo signoff	Code XX.XXX	Earthmoving contractor	Operator			Yes	
Maintenance watering	Watering	Code XX.XXX	Earthmoving contractor	Job manager	Each area		Yes	

**Figure 27 – Example Revegetation Inspection and Test Plan (Source: IECA, 2008)**

**NON-CONFORMANCE REPORT (Example only)**

<b>Job Name:</b>	<b>Job No:</b>
<b>Date:</b>	<b>Client:</b>
<b>Details of non-conformance:</b>	
<b>Details of specification/procedure not conforming to:</b>	
<b>Non-conformance raised by:</b>	<b>Date:</b>
<b>Short-term preventative action:</b>	
<b>Estimated cost of rework/re-training/waste:</b>	
<b>Long-term preventative action:</b>	
<b>Accepted/rejected by the Client:</b>	<b>Date:</b>
<b>Signed:</b>	
<b>Non-conformance resolved:</b>	<b>Date:</b>
<b>Signed:</b>	



### **ESCP signature box**

This Erosion and Sediment Control Plan satisfies the following requirements:

- (i) The intent and minimum standards established by all relevant local, state and federal policies relating to erosion and sediment control.
- (ii) Review and approval by personnel suitably trained and experienced (to a degree appropriate for the given type and size of the land disturbance) in each of the following categories: construction, soil science, hydrology/hydraulics, and site revegetation and rehabilitation.
- (iii) Is both reasonable and practicable.
- (iv) Contains sufficient information to allow appropriate implementation of the plan(s).

Signature:

Date:

Printed name:

### **Option A – ESCP signature box**

This Erosion and Sediment Control Plan satisfies the following requirements:

- (i) The intent and minimum standards established by all relevant local, state and federal policies relating to erosion and sediment control.
- (ii) Review and approval by personnel suitably trained and experienced (to a degree appropriate for the given type and size of the land disturbance) in each of the following categories: construction, soil science, hydrology/hydraulics, and site revegetation and rehabilitation.
- (iii) Is both reasonable and practicable.
- (iv) Contains sufficient information to allow appropriate implementation of the plan(s).
- (v) The Construction Drainage Plan has been reviewed and approved by a suitably experienced hydraulic engineer and/or hydrologist.

Signature:

Date:

Printed name:

### **Option B – ESCP signature box with hydrology sign-off**

This Erosion and Sediment Control Plan satisfies the following requirements:

- (i) The intent and minimum standards established by all relevant local, state and federal policies relating to erosion and sediment control.
- (ii) Review and approval by personnel suitably trained and experienced (to a degree appropriate for the given type and size of the land disturbance) in each of the following categories: construction, soil science, hydrology/hydraulics, and site revegetation and rehabilitation.
- (iii) Is both reasonable and practicable.
- (iv) Contains sufficient information to allow appropriate implementation of the plan(s).
- (v) The Construction Drainage Plan has been reviewed and approved by a suitably experienced hydraulic engineer and/or hydrologist.
- (vi) The sediment basin embankment has been reviewed and approved by a suitably experienced geotechnical specialist.

Signature:

Date:

Printed name:

### **Option C – ESCP signature box with hydrology and embankment safety sign-off**

## Construction contracts



Road construction



Basins retained for stormwater treatment



Batter without appropriate erosion control



Progressive batter revegetation

### Good construction contracts

- In general, an appropriately worded construction contract has a **greater** potential to produce favourable environmental outcomes than a well-prepared ESC Plan.
- The best ESCP is easily 'crippled' if the wording of the construction contract either:
  - prevents the main contractor or their sub-contractors from implementing the plan, or
  - provides the contractor with loopholes to avoid their environmental duty.

### Allowing space of major sediment traps

- The available road reserve width, or the contracted use of neighbouring land, **must** allow the contractor sufficient space to construct and operate appropriately sized sediment basins at key locations.
- The allocation of sufficient space for sediment basins is more likely to occur if these basins are incorporated into the road's permanent stormwater treatment infrastructure.
- Space limitations often prevent the use of sediment basins in urban settings.

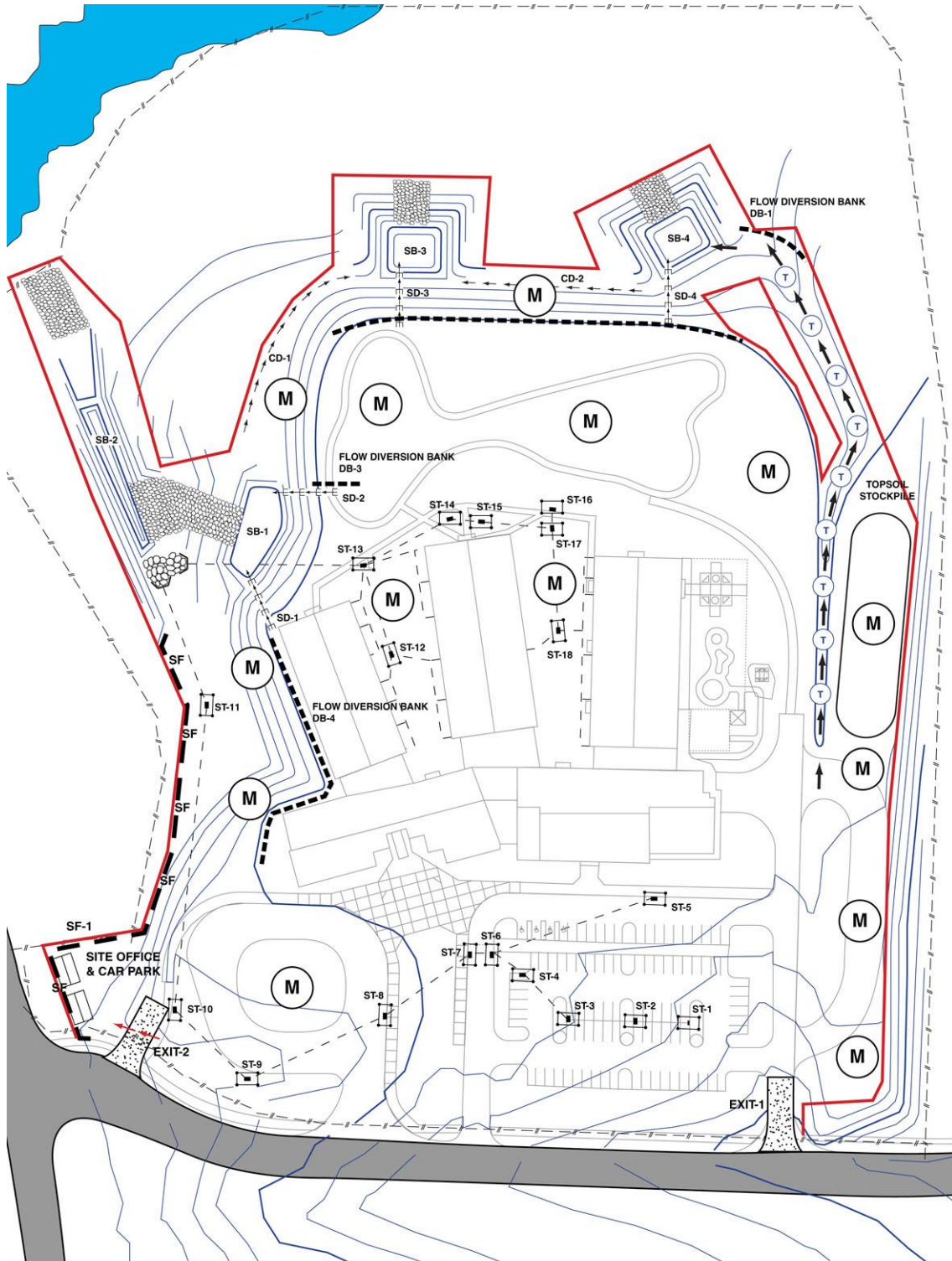
### Batter stabilisation vs batter revegetation

- It is **NOT** appropriate to leave finished road batters exposed to the weather simply because the contractor feels that:
  - batter stabilisation measures consist solely of batter revegetation, or that
  - batter revegetation has been sub-contracted to another organisation that currently does not have access to the site.
- If road batters are not to be immediately vegetated, then the contract **must** specify temporary erosion control measures.

### Maintenance and revegetation provisions

- The construction contract must include adequate provisions for:
  - ongoing maintenance of ESC measures
  - progressive site stabilisation and revegetation.
- 'Inspection and Test Plans' should be incorporated into the site revegetation specifications wherever practical.
- 'Witness Points' or 'Hold Points' can be used to ensure that road batters are stabilised at maximum 3 m lifts.

# Case Study – Hodge Road School, Final ESCP (not the actual 1995 ESCP)



**LEGEND:**

- ST-16 BLOCK & AGGREGATE DROP INLET PROTECTION
- LIMITS OF DISTURBANCE
- SD-4 SLOPE DRAIN

**PLAN REVIEW**  
 This Erosion and Sediment Control Plan (ESCP) has been reviewed by the undersigned and to the best of my knowledge and belief, it conforms to the requirements of the State of Queensland, and the Bundaberg Regional Council.

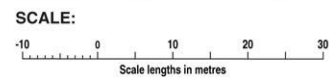
Reviewer: \_\_\_\_\_ Date: \_\_\_\_\_  
 Organisation: \_\_\_\_\_

**PLAN REVIEW (REV. 1)**  
 This revised Erosion and Sediment Control Plan (Rev. 1) has been reviewed by the undersigned and to the best of my knowledge and belief, the amendments conform to the requirements of the State of Queensland, and the Bundaberg Regional Council.

Reviewer: \_\_\_\_\_ Date: \_\_\_\_\_  
 Organisation: \_\_\_\_\_

**CONSTRUCTION NOTE 1:**  
 THIS CONTRACT IS FOR PHASE 1 SITE DEVELOPMENT. THE WORK TO BE PERFORMED INCLUDES:  
 CONTRACT A: EROSION AND SEDIMENT CONTROL, SITE CLEARING, EXISTING ROADS, PRIORITY DRAINAGE (NON-BUILDING), TEMPORARY SOIL STABILISATION PRIOR TO SITE REVEGETATION.  
 CONTRACT B: SITE REVEGETATION.  
 EACH PHASE OF CONTRACT B SHALL BE COMMENCED WITHIN TWO WEEKS OF THE COMPLETION OF EACH STAGE OF WORKS LISTED WITHIN THE CONSTRUCTION SCHEDULE.

**CONSTRUCTION NOTE 2:**  
 THE PROJECT SITE IS COVERED WITH NATIVE AND NON-NATIVE VEGETATION. THE SITE HAS PREVIOUSLY BEEN LOGGED, BUT REMAINING NATIVE TREES WERE RETAINED. THE SITE IS TO BE CLEARED AND GRUBBED WITHIN THE NOMINATED LIMITS OF A VEGETATION PROTECTION ORDER (VPO) HAS BEEN ISSUED FOR TREES THAT ARE TO BE RETAINED.  
 CONTRACTOR SHALL TAKE ALL REASONABLE MEASURES TO MODIFY THE LAND CONTOURING AND SURFACE DRAINAGE TO BEST PROTECT REMAINING VEGETATION WHERE NECESSARY. CONSULT WITH THE DEPARTMENT'S ARBORIST.



State of Queensland  
 Department of Education  
 Hodge Road Elementary School  
 Yupypup County

Phase 1 Site Development	Date: November, 1994
Erosion and Sediment Control Plan	Plan Number: HR021-REV-1

Figure 28 – Final Erosion and Sediment Control Plan (presented in portrait form)

# Case Study – Hodge Road Elementary School (not the actual 1995 ESCP)



**LEGEND:**

- ST-16 BLOCK & AGGREGATE DROP INLET PROTECTION
- LIMITS OF DISTURBANCE
- SD-4 SLOPE DRAIN

**PLAN REVIEW**  
 This Erosion and Sediment Control Plan (ESCP) has been reviewed by the undersigned and to the best of my knowledge and belief, it conforms to the requirements of the State of Queensland, and the Bundaberg Regional Council.

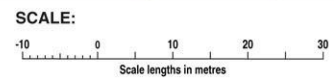
Reviewer: \_\_\_\_\_ Date: \_\_\_\_\_  
 Organisation: \_\_\_\_\_

**PLAN REVIEW (REV. 1)**  
 This revised Erosion and Sediment Control Plan (Rev. 1) has been reviewed by the undersigned and to the best of my knowledge and belief, the amendments conform to the requirements of the State of Queensland, and the Bundaberg Regional Council.

Reviewer: \_\_\_\_\_ Date: \_\_\_\_\_  
 Organisation: \_\_\_\_\_

**CONSTRUCTION NOTE 1:**  
 THIS CONTRACT IS FOR PHASE 1 SITE DEVELOPMENT. THE WORK TO BE PERFORMED INCLUDES:  
**CONTRACT A:** EROSION AND SEDIMENT CONTROL, SITE CLEARING, EXISTING ROADS, PROPERTY DRAINAGE (NON-BUILDING), TEMPORARY SOIL STABILISATION PRIOR TO SITE REVEGETATION.  
**CONTRACT B:** SITE REVEGETATION.  
 EACH PHASE OF CONTRACT B SHALL BE COMMENCED WITHIN TWO WEEKS OF THE COMPLETION OF EACH STAGE OF WORKS LISTED WITHIN THE CONSTRUCTION SCHEDULE.

**CONSTRUCTION NOTE 2:**  
 THE PROJECT SITE IS COVERED WITH NATIVE AND NON-NATIVE VEGETATION. THE SITE HAS PREVIOUSLY BEEN LOGGED, BUT REMAINING HARDY TREES WERE RETAINED. THE SITE IS TO BE CLEARED AND GRUBBED WITHIN THE NOMINATED LIMITS OF A VEGETATION PROTECTION ORDER (VPO) HAS BEEN ISSUED FOR TREES THAT ARE TO BE RETAINED.  
**CONTRACTOR:** SHALL TAKE ALL REASONABLE MEASURES TO MODIFY THE LAND CONTOURING AND SURFACE DRAINAGE TO BEST PROTECT REMAINED VEGETATION WHERE NECESSARY. CONSULT WITH THE DEPARTMENT'S ARBORIST.



State of Queensland Department of Education	
Hodge Road Elementary School Yupyup County	
Phase 1 Site Development	Date: November, 1994
Erosion and Sediment Control Plan	Plan Number: HR021-REV-1

Figure 29 – Final site layout with ESC measures for the Hodge Road school site

# Case Study – Alternative Erosion and Sediment Control Plan



**LEGEND:**

	BLOCK & AGGREGATE DROP INLET PROTECTION
	LIMITS OF DISTURBANCE
	SLOPE DRAIN

**PLAN REVIEW**  
 This Erosion and Sediment Control Plan (ESCP) has been reviewed by the undersigned and to the best of my knowledge and belief, it conforms to the requirements of the State of Queensland, and the Bundaberg Regional Council.

Reviewer: \_\_\_\_\_ Date: \_\_\_\_\_  
 Organisation: \_\_\_\_\_

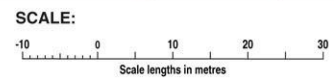
**PLAN REVIEW (REV. 1)**  
 This revised Erosion and Sediment Control Plan (Rev. 1) has been reviewed by the undersigned and to the best of my knowledge and belief, the amendments conform to the requirements of the State of Queensland, and the Bundaberg Regional Council.

Reviewer: \_\_\_\_\_ Date: \_\_\_\_\_  
 Organisation: \_\_\_\_\_

**CONSTRUCTION NOTE 1:**  
 THIS CONTRACT IS FOR PHASE 1 SITE DEVELOPMENT. THE WORK TO BE PERFORMED INCLUDES:  
 CONTRACT A: EROSION AND SEDIMENT CONTROL, SITE CLEARING, EXISTING ROADS, PROPERTY DRAINAGE (NON-BUILDINGS), TEMPORARY SOIL STABILISATION PRIOR TO SITE REVEGETATION.

**CONTRACT B:** SITE REVEGETATION.  
 EACH PHASE OF CONTRACT B SHALL BE COMMENCED WITHIN TWO WEEKS OF THE COMPLETION OF EACH STAGE OF WORKS LISTED WITHIN THE CONSTRUCTION SCHEDULE.

**CONSTRUCTION NOTE 2:**  
 THE PROJECT SITE IS COVERED WITH NATIVE AND NON-NATIVE VEGETATION. THE SITE HAS PREVIOUSLY BEEN LOGGED, BUT REMAINING HARDY TREES WERE RETAINED. THE SITE IS TO BE CLEARED AND GRUBBED WITHIN THE NOMINATED LIMITS OF A VEGETATION PROTECTION ORDER (VPO) HAS BEEN ISSUED FOR TREES THAT ARE TO BE RETAINED.  
 CONTRACTOR SHALL TAKE ALL REASONABLE MEASURES TO MODIFY THE LAND CONTOURING AND SURFACE DRAINAGE TO BEST PROTECT REMAINING VEGETATION WHERE NECESSARY. CONSULT WITH THE DEPARTMENT'S ARBORIST.



State of Queensland  
 Department of Education  
 Hodge Road Elementary School  
 Yupypup County

Phase 1 Site Development

Erosion and Sediment Control Plan

Date:	November, 1994
Plan Number:	HR021-REV-1

Figure 30 – Alternative ESCP with Type-A sediment basins

## Example technical notes

This Section provides example technical notes for use on Erosion and Sediment Control Plans (ESCPs). Not all of the following notes will be applicable to each site. The following example technical notes may be modified as necessary to ensure applicability to a given site or construction activity.

***It is the designer's responsibility to ensure that all technical notes incorporated into an ESCP are applicable to the expected site conditions and any specified operational requirements, such as those specified within the development approval conditions.***

### General

1. Additional erosion and sediment control measures must be implemented and a revised Erosion and Sediment Control Plan (ESCP) must be submitted for approval in the event that site conditions change significantly from those considered within the ESCP.
2. Additional erosion and sediment control measures must be implemented and a revised Erosion and Sediment Control Plan (ESCP) must be submitted for approval in the event that the implemented works fail to achieve the stated "objective" of the ESCP, the local government ESC standard, or the State's environmental protection requirements.  
*(alternative to above)*
3. Where there is a high probability that serious or material environmental harm may occur as a result of sediment leaving the site, appropriate additional erosion and sediment control measures must be implemented such that all reasonable and practicable measures are being taken to prevent or minimise such harm. Only those works necessary to minimise or prevent environmental harm shall be conducted on-site prior to approval of the amended Erosion and Sediment Control Plan (ESCP).
4. Where there is a high probability that serious or material environmental harm may occur as a result of sediment leaving the site, a new or amended Erosion and Sediment Control Plan (ESCP) must be submitted for approval. Only those works necessary to minimise or prevent environmental harm shall be conducted on-site prior to approval of the new or amended ESCP. *(alternative to above)*
5. In circumstances where it is considered necessary to prepare an amended Erosion and Sediment Control Plan (ESCP), and where the delivery of such an amended ESCP is not imminent, then all necessary new or modified erosion and sediment control works must be in accordance with [name of document]. Upon approval of the amended ESCP, all works must be implemented in accordance with the amended plan.

### Land clearing

6. Land clearing must be delayed as long as practicable and must be undertaken in conjunction with development of each stage of works, unless otherwise approved by [insert name or title].
7. All reasonable and practicable efforts must be taken to delay the removal of, or disturbance to, existing ground cover (organic or inorganic) prior to land-disturbing activities.
8. Bulk tree clearing must occur in a manner that minimises disturbance to existing ground cover (organic or inorganic).
9. Bulk tree clearing and grubbing of the site must be immediately followed by specified temporary stabilisation measures (e.g. temporary grassing, or mulching) prior to commencement of each stage of construction works.
10. Disturbance to natural watercourses (including bed and banks) and their associated riparian zones must be limited to the minimum practicable.
11. No land clearing shall be undertaken unless preceded by the installation of adequate drainage and sediment control measures, unless such clearing is required for the purpose of installing such measures, in which case, only the minimum clearing required to install such measures shall occur.

12. Land clearing must be limited to 5m from the edge of proposed constructed works, 2 m from essential construction traffic routes, and a total of 10m width for construction access, unless otherwise approved by [*insert name or title*].
13. Prior to land clearing, areas of protected vegetation, and significant areas of retained vegetation must be clearly identified (e.g. with high-visibility tape, or light fencing) for the purposes of minimising the risk of unnecessary land clearing.
14. All reasonable and practicable measures must be taken to minimise the removal of, or disturbance to, those trees, shrubs and ground covers (organic or inorganic) that are intended to be retained.
15. All land clearing must be in accordance with the Federal, State and local government Vegetation Protection/Preservation requirements and/or policies.
16. Land clearing is limited to the minimum practicable during those periods when soil erosion due to wind, rain or surface water is possible.
17. Land clearing must not extend beyond that necessary to provide up to eight (8) weeks of site activity during those months when the expected rainfall erosivity is less than 100, six (6) weeks if between 100 and 285, four (4) weeks if between 285 and 1500, and two (2) weeks if greater than 1500.
18. Land clearing must not extend beyond that necessary to provide up to eight (8) weeks of site activity during those months when the actual or average rainfall is less than 45mm, six (6) weeks if between 45 and 100mm, four (4) weeks if between 100 and 225mm, and two (2) weeks if greater than 225mm. (*alternative to above*)

#### **Site access**

19. Prior to the commencement of site works, the location of the site access point(s) must be verified with [*insert relevant authority*].
20. Site access must be restricted to the minimum practical number of locations.
21. Site exit points must be appropriately managed to minimise the risk of sediment being tracked onto sealed, public roadways.
22. Stormwater runoff from access roads and stabilised entry/exit points must drain to an appropriate sediment control device.

#### **Soil and stockpile management**

23. All reasonable and practicable measures must be taken to obtain the maximum benefit from existing topsoil, including:
  - (i) Where the proposed area of soil disturbance does not exceed 2500m<sup>2</sup>, and the topsoil does not contain undesirable weed seed, the top 100mm of soil located within areas of proposed soil disturbance (including stockpile areas) must be stripped and stockpiled separately from the remaining soil.
  - (ii) Where the proposed area of soil disturbance exceeds 2500m<sup>2</sup>, and the topsoil does not contain undesirable weed seed, the top 50mm of soil must be stripped and stockpiled separately from the remaining topsoil, and spread as a final surface soil.
  - (iii) In areas where the topsoil contains undesirable weed seed, the affected soil must be suitably buried or removed from the site.
24. Stockpiles of erodible material that has the potential to cause environmental harm if displaced, must be:
  - (i) Appropriately protected from wind, rain, concentrated surface flow and excessive up-slope stormwater surface flows.
  - (ii) Located at least 2m from any hazardous area, retained vegetation, or concentrated drainage line.
  - (iii) Located up-slope of an appropriate sediment control system.
  - (iv) Provided with an appropriate protective cover (synthetic, mulch or vegetative) if the materials are likely to be stockpiled for more than 28 days.

- (v) Provided with an appropriate protective cover (synthetic, mulch or vegetative) if the materials are likely to be stockpiled for more than 10 days during those months that have a high erosion risk.
  - (vi) Provided with an appropriate protective cover (synthetic, mulch or vegetative) if the materials are likely to be stockpiled for more than 5 days during those months that have an extreme erosion risk.
25. A suitable flow diversion system must be established immediately up-slope of a stockpile of erodible material that has the potential to cause environmental harm if displaced, if the up-slope catchment area draining to the stockpile exceeds 1500m<sup>2</sup>.

#### **Site management**

26. All office facilities and operational activities must be located such that any liquid effluent (e.g. process water, wash-down water, effluent from equipment cleaning, or plant watering), can be totally contained and treated within the site.
27. The construction schedule must aim to minimise the duration that any and all areas of soil are exposed to the erosive effects of wind, rain and surface water.
28. Land-disturbing activities must be undertaken in accordance with the Erosion and Sediment Control Plan (ESCP) and associated development conditions.
29. Land-disturbing activities must be undertaken in such a manner that allows all reasonable and practicable measures to be undertaken to:
- (i) allow stormwater to pass through the site in a controlled manner and at non-erosive flow velocities up to the specified design storm discharge;
  - (ii) minimise soil erosion resulting from rain, water flow and/or wind;
  - (iii) minimise adverse effects of sediment runoff, including safety issues;
  - (iv) prevent, or at least minimise, environmental harm resulting from work-related soil erosion and sediment runoff;
  - (v) ensure that the value and use of land/properties adjacent to the development (including roads) are not diminished as a result of the adopted ESC measures.
30. All erosion and sediment control measures must conform to the standards and specifications contained in:
- (i) the development approval condition(s) issued by [*insert appropriate authority*]; and
  - (ii) the approved ESCP and supporting documentation; or
  - (iii) the latest version of [*insert relevant document*] if the standards and specifications are not contained in the approved ESCP.
31. Any works that may cause significant soil disturbance and are ancillary to any activity for which regulatory body approval is required, must not commence before the issue of that approval.
32. Additional and/or alternative ESC measures must be implemented in the event that site inspections, the site's Monitoring and Maintenance Program, or the regulatory authority, identifies that unacceptable off-site sedimentation is occurring as a result of the work activities.
33. Additional and/or alternative ESC measures must be implemented in the event that [*insert relevant name, title or authority*], identifies that unacceptable off-site sedimentation is occurring as a result of the work activities. (*alternative to above*)
34. Land-disturbing activities must not cause unnecessary soil disturbance if an alternative construction process is available that achieves the same or equivalent outcomes at an equivalent cost.
35. Sediment (including clay, silt, sand, gravel, soil, mud, cement and ceramic waste) deposited off the site as a direct result of an on-site activity, must be collected and the area appropriately cleaned/rehabilitated as soon as reasonable and practicable, and in a manner that gives appropriate consideration to the safety and environmental risks associated with the sediment deposition.

36. Wherever reasonable and practicable, brick, tile and masonry cutting must be carried out on a pervious surface, such as grass, or open soil, or in such a manner that all sediment-laden runoff is prevented from discharging into a gutter, drain, or water body.
37. Adequate waste collection bins must be provided on-site and maintained such that potential and actual environmental harm resulting from such material waste is minimised.
38. Concrete waste and chemical products, including petroleum and oil-based products, must be prevented from entering an internal water body, or an external drain, stormwater system, or water body.
39. All flammable and combustible liquids, including all liquid chemicals if such chemicals could potentially be washed or discharged from the site, are to be stored and handled on-site in accordance with relevant standards such as AS1940 *The storage and handling of flammable and combustible liquids*.
40. Trenches not located within roadways must be backfilled, capped with topsoil, and compacted to a level at least 75mm above adjoining ground level and appropriately stabilised.
41. All stormwater, sewer line and other service trenches, not located within roadways, must be mulched and seeded, and otherwise appropriately stabilised within 7 days after backfill.
42. No more than 150m of a stormwater, sewer line or other service trench must be open at any one time.
43. Site spoil must be lawfully disposed of in a manner that does not result in ongoing soil erosion or environmental harm.
44. All fill material placed on site must comprise only natural earth and rock, and is to be free of contaminants, be free draining, and be compacted in layers not exceeding 300mm to 90% modified maximum dry density in accordance with AS1289.

#### **Drainage control**

45. All drainage control measures must be applied and maintained in accordance with [*insert relevant document*].
46. Wherever reasonable and practicable, stormwater runoff entering the site from external areas, and non-sediment laden (clean) stormwater runoff entering a work area or area of soil disturbance, must be diverted around or through that area in a manner that minimises soil erosion and the contamination of that water for all discharges up to the specified design storm discharge.
47. During the construction period, all reasonable and practicable measures must be implemented to control flow velocities in such a manner that prevents soil erosion along drainage paths and at the entrance and exit of all drains and drainage pipes during all storms up to the relevant design storm discharge.
48. To the maximum degree reasonable and practicable, all waters discharged during the construction phase must discharge onto stable land, in a non-erosive manner, and at a legal point of discharge.
49. Wherever reasonable and practicable, "clean" surface waters must be diverted away from sediment control devices and any untreated, sediment-laden waters.
50. During the construction period, roof water must be managed in a manner that minimises soil erosion throughout the site, and site wetness within active work areas.

### **Erosion control**

51. All erosion control measures must be applied and maintained in accordance with [*insert relevant document*].
52. The application of liquid-based dust suppression measures must ensure that sediment-laden runoff resulting from such measures does not create a traffic or environmental hazard.
53. All temporary earth banks, flow diversion systems, and embankments associated with constructed sediment basins must be machine-compacted, seeded and mulched for the purpose of establishing a temporary vegetative cover within 10 days after grading.
54. Unprotected slope lengths must not exceed 80m, or an equivalent vertical fall of 3m during the period [*insert date/month*] and [*insert date/month*].
55. Unprotected slope lengths must not exceed 80m, or an equivalent vertical fall of 3m prior to specified shutdown periods or when rainfall is expected to exceed [*insert value*] within a 24 hour period, or the monthly rainfall is expected to exceed [*insert value*].
56. The construction and stabilisation of earth batters steeper than 6:1 (H:V) must be staged such that no more than 3 vertical-metres of any batter is exposed to rainfall at any instant.
57. Synthetic reinforced erosion control mats and blankets must not be placed within, or adjacent to, riparian zones and watercourses if such materials are likely to cause environmental harm to wildlife or wildlife habitats.
58. A minimum 60% ground cover must be achieved on all non-completed earthworks exposed to accelerated soil erosion if further construction activities or soil disturbances are likely to be suspended for more than 30 days during those months when the expected rainfall erosivity is less than 60; minimum 70% cover within 30 days if between 60 and 100; minimum 70% cover within 20 days if between 100 and 285; minimum 75% cover within 10 days if between 285 and 1500; and minimum 80% cover within 5 days if greater than 1500.
59. A minimum 60% ground cover must be achieved on all non-completed earthworks exposed to accelerated soil erosion if further construction activities or soil disturbances are likely to be suspended for more than 30 days during those months when the expected rainfall erosivity is less than 30mm; minimum 70% cover within 30 days if between 30 and 45mm; minimum 70% cover within 20 days if between 45 and 100mm; minimum 75% cover within 10 days if between 100 and 225mm; and minimum 80% cover within 5 days if greater than 225mm. (*alternative to above*)

### **Sediment control**

60. All sediment control measures must be applied and maintained in accordance with [*insert relevant document*].
61. Optimum benefit must be made of every opportunity to trap sediment within the work site, and as close as practicable to its source.
62. Sediment traps must be installed and operated to both collect and retain sediment.
63. The potential safety risk of a proposed sediment trap to site workers and the public must be given appropriate consideration, especially those devices located within publicly accessible areas.
64. All reasonable and practicable measures must be taken to prevent, or at least minimise, the release of sediment from the site.
65. Suitable all-weather maintenance access must be provided to all sediment control devices.
66. Sediment control devices must be de-silted and made fully operational as soon as reasonable and practicable after a sediment-producing event, whether natural or artificial, if the device's sediment retention capacity falls below 75% of its design retention capacity.
67. Materials, whether liquid or solid, removed from sediment control devices during maintenance or decommissioning, must be disposed of in a manner that does not cause ongoing soil erosion or environmental harm.

68. As-Constructed plans must be prepared for all constructed sediment basins and associated emergency spillways. Such plans must appropriately verify the basin's dimensions, levels and volumes, and must be submitted to *[insert name/title/authority]* within 14 calendar days of the construction of each basin.
69. Constructed sediment basins must be maintained and fully operational throughout the construction period and until each basin's catchment area achieves *[insert minimum required percentage cover]* ground cover on all soil surfaces.
70. Settled sediment must be removed from sediment basins when the volume of the sediment exceeds the designated sediment storage volume, or the design maximum sediment storage elevation.

**Site rehabilitation**

71. All disturbed areas identified as very low, low, medium, high, or extreme erosion risk must be suitably stabilised within 30, 30, 20, 10 or 5 days respectively, or prior to anticipated rainfall, whichever is the greater, from the day that soil disturbances on the area have been finalised.
72. A minimum 60% ground cover must be achieved on all completed earthworks exposed to accelerated soil erosion within 30 days during those months when the expected rainfall erosivity is less than 60; minimum 70% cover within 30 days if between 60 and 100; minimum 70% cover within 20 days if between 100 and 285; minimum 75% cover within 10 days if between 285 and 1500; and minimum 80% cover within 5 days if greater than 1500.
73. A minimum 60% ground cover must be achieved on all completed earthworks exposed to accelerated soil erosion within 30 days during those months when the expected rainfall erosivity is less than 30mm; minimum 70% cover within 30 days if between 30 and 45mm; minimum 70% cover within 20 days if between 45 and 100mm; minimum 75% cover within 10 days if between 100 and 225mm; and minimum 80% cover within 5 days if greater than 225mm. (*alternative to above*)
74. No completed earthwork surface must remain denuded for longer than 60 days.
75. The type of ground cover applied to completed earthworks is compatible with the anticipated long-term land use, environmental risk, and site rehabilitation measures.
76. Unless otherwise directed by *[insert name/title/authority]* or where directed by the approved revegetation plan, topsoil must be placed at a minimum depth of 75mm on slopes 4:1 (H:V) or flatter, and 50mm on slopes steeper than 4:1.
77. The pH (soil:water 1:5) of the topsoil must be between *[insert value]* and *[insert value]* prior to initiating the establishment of vegetation.
78. The pH level (soil:water 1:5) of topsoil must be adequate to enable establishment and growth of the specified vegetation.
79. Soil ameliorants must be added to the soil in accordance with the approved landscape/revegetation plans and/or soil analysis.
80. Soil density/compaction must be adjusted prior to seeding/planting in accordance with *[insert specifications, soil report or appropriate reference plan]*.
81. Temporary site stabilisation procedures must commence at least 30 days prior to the nominated site shutdown date. At least 70% stable cover of all unstable and/or disturbed soil surfaces must be achieved prior to *[insert the start of shutdown]*. The stabilisation works must not rely upon the longevity of non-vegetated erosion control blankets, or temporary soil binders.
82. All unstable or disturbed soil surfaces must be adequately stabilised against erosion (minimum 70% soil cover per square metre) prior to commencement of use, or survey plan endorsement.

### **Sediment basin rehabilitation**

83. Required drainage, erosion and sediment control measures during the decommissioning and rehabilitation of a sediment basin must comply with the same standards specified for the normal construction works.
84. Upon decommissioning of a sediment basin, all water and sediment must be removed from the basin prior to removal of the embankment (if any). Any such material, liquid or solid, must be disposed of in a manner that will not create an erosion or pollution hazard.
85. A basin's catchment conditions associated with the staged decommissioning of the basin from a Type 1 to a Type 2 sediment trap must comply with the specified sediment control standard.
86. If an alternative, permanent, outlet structure is to be constructed prior to stabilisation of the up-slope catchment area, then this outlet structure must not be made operational if it will adversely affect the required operation of the sediment basin.
87. The permanent stormwater treatment features (e.g. vegetation and filtration media) must be appropriately protected from the adverse effects of sediment runoff.
88. A sediment basin must not be decommissioned until all up-slope site stabilisation measures have been implemented and are appropriately working to control soil erosion and sediment runoff in accordance with the specified ESC standard.
89. Immediately prior to the construction of the permanent stormwater treatment device, appropriate flow bypass conditions must be established to prevent sediment-laden water entering the device.
90. Immediately following the construction of the filter media of the permanent stormwater treatment device, the filter media must be covered by heavy-duty filter cloth (minimum bidum A44 or equivalent) and a minimum 200mm layer of earth or sacrificial filter media. Such earth and filter cloth must not be removed from the device until suitable surface conditions are achieved within the basin's catchment area.
91. Immediately following the construction of the *[insert description, e.g. wetland, bioretention system]* an appropriate Type 2 sediment trap must be installed in a manner to prevent sediment intrusion into the device.
92. The minimum sediment control standard for the protection of the permanent stormwater treatment device during the construction and maintenance phases is a Type 2 sediment trap. (alternative to above)
93. Plant establishment within the permanent stormwater treatment device must be delayed until sediment intrusion into the device is suitably under control.
94. Upon suitable conditions being achieved within the basin's catchment area, the operational features of the permanent stormwater treatment system must be made fully operational (i.e. maintenance and/or reconstruction as required).
95. The permanent stormwater treatment features of the rehabilitated basin must not be made operational until all up-slope site stabilisation measures have been implemented and are appropriately working to control soil erosion and sediment runoff in accordance with the specified ESC standard. (alternative to above)
96. Upon the approval of *[insert authority]*, the newly constructed permanent stormwater treatment features of the basin may be made operational if such actions do not prevent the site from operating at the required sediment control standard. (alternative to above)

### **Site monitoring**

97. All water quality data, including dates of rainfall, dates of testing, testing results and dates of water release, must be kept in an on-site register. The register is to be maintained up to date for the duration of the approved works and be available on-site for inspection by *[insert name of regulatory authority]* on request.
98. At nominated instream water monitoring sites, a minimum of 3 water samples must be taken and analysed, and the average result used to determine quality.
99. Sediment basin water quality samples must be taken at a depth no greater than 200mm above the level of settled sediment.
100. All environmentally relevant incidents must be notified to the regulatory authority (if required by local legislation or policy), and the incident details recorded in a field log that must remain accessible to all relevant regulatory authorities.

### **Site maintenance**

101. All erosion and sediment control measures, including drainage control measures, must be maintained in proper working order at all times during their operational lives.
102. All temporary erosion and sediment control measures, including drainage control measures, must be fully operational and maintained in proper working order at all times during the maintenance period as specified by *[insert name of authority]*.
103. All temporary erosion and sediment control measures, including drainage control measures, must be removed after achieving a satisfactory "off-maintenance inspection" by *[insert name of authority]*.
104. All drainage, erosion and sediment control measures must be inspected:
  - (i) at least daily (when work is occurring on-site);
  - (ii) at least weekly (when work is not occurring on-site);
  - (iii) within 24 hours of expected rainfall; and
  - (iv) within 18 hours of a rainfall event of sufficient intensity and duration to cause runoff on-site).
105. Washing/flushing of sealed roadways must only occur where sweeping has failed to remove sufficient sediment and there is a compelling need to remove the remaining sediment (e.g. for safety reasons). In such circumstances, all reasonable and practicable sediment control measures must be used to prevent, or at least minimise, the release of sediment into receiving waters. Only those measures that will not cause safety and property flooding issues shall be employed. Sediment removed from roadways must be disposed of in a lawful manner that does not cause ongoing soil erosion or environmental harm.
106. Sediment removed from sediment traps and places of sediment deposition must be disposed of in a lawful manner that does not cause ongoing soil erosion or environmental harm.
107. Maintenance mowing of all road shoulders, table drains, batters and other surfaces likely to experience accelerated soil erosion must aim to leave the grass length no shorter than 50mm where reasonable and practicable.
108. Maintenance mowing must be done in a manner that will not damage the profile of formed, soft edges, such as the crest of earth embankments, and open grassed drains.

## **3. Road Construction**

## Introduction



Photo supplied by Catchments & Creeks Pty Ltd

**Road construction**



Photo supplied by Catchments & Creeks Pty Ltd

**Sediment basin**



Photo supplied by Catchments & Creeks Pty Ltd

**Flow diversion drains**



Photo supplied by Catchments & Creeks Pty Ltd

**Type 2 sediment trap**

## Introduction

- The preparation of ESCPs for road construction projects is primarily based on managing the following key issues:
  - locating major sediment traps
  - diversion of run-on water
  - treating dirty water runoff from the road
  - managing soil stockpiles
  - control of soil erosion on road batters
  - management of waterway crossings
  - preparing the site for imminent storms
  - site revegetation.

## Locating major sediment traps

- One of the most effective ways of controlling sediment runoff from construction activities is through the use of sediment basins.
- Ideally, the need for, and location of, sediment basins should be resolved during the planning phase of new roads.
- Sediment basins are most commonly located adjacent to waterway and drainage line crossings.

## Diversion of run-on water

- During the construction phase there are two forms of drainage:
  - **temporary drainage**, which is active only during the construction phase
  - **permanent drainage**, which is operational during the life of the road.
- Drainage control measures are used to divert 'clean' run-on water away from road works and newly formed road batters.

## Treating 'dirty' water runoff

- Sediment traps can be classified as: Type 1, Type 2, Type 3, & supplementary.
- Type 1 sediment traps, which include most sediment basins, are designed to capture a full range of sediment particles from sands to clays.
- Type 2 sediment traps are designed to focus on the capture of sands and silts.
- Type 3 sediment traps are primarily designed to trap coarse-grained particles (sand) larger than 0.14 mm.

## Key issues on road construction projects



**Topsoil stockpile**

### Managing soil stockpiles

- Road construction often involves the long-term stockpiling of both topsoil and embankment fill.
- Critical issues include:
  - investigating if the plant seed within the topsoil should be preserved
  - locating stockpiles away from road works and overland flow paths
  - controlling soil moisture levels in proposed fill material
  - sediment control measures.



**Batter stabilisation**

### Control of soil erosion on road batters

- Batter stabilisation can be integrated with site revegetation, or treated as a separate process.
- **'Batter stabilisation'** is a part of the earth works phase that must occur immediately after a new batter is formed.
- **'Batter revegetation'** can be implemented by a separate contractor after earthworks are completed, but in such cases, the batter must be stabilised with temporary erosion control measures as part of the earthworks contract.



**Approaching storm**

### Preparing the site for imminent storms

- Construction sites need to be prepared for both likely and unlikely, but possible, weather conditions.
- Critical issues include:
  - conducting a pre-storm site inspection
  - establish temporary flow diversions around newly constructed works
  - stabilising drainage pathways
  - securing erosion control blankets
  - establishing spill-through weirs or flow bypass around sediment controls.



**Batter revegetation**

### Site revegetation

- Final site rehabilitation measures should be treated as a separate construction item to temporary erosion control measures.
- Revegetation plans should provide details or contract conditions on:
  - temporary revegetation measures in the event of an unplanned site shut-down
  - timing of site revegetation relative to the time of year or assessed erosion risk
  - method of plant establishment and performance/compliance verification.

## Construction of a local road

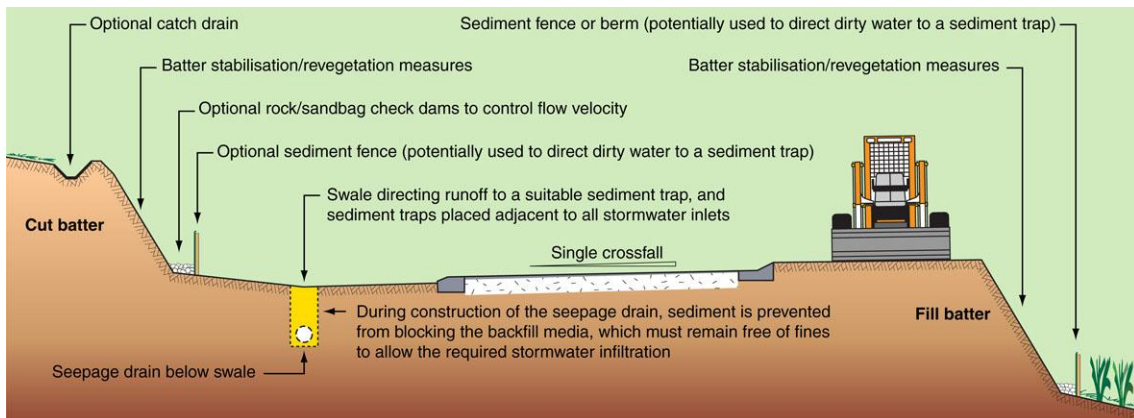


Photo supplied by Catchments & Creeks Pty Ltd

**Single crossfall local road**

## Erosion and sediment control practices

- It is often impractical to incorporate large sediment basins into the construction of local roads, unless these roads form part of a larger subdivision project.
- Sediment controls are typically limited to Type 3 and supplementary sediment traps, with Type 2 sediment traps used at field inlets (but, not kerb inlets), and at waterway crossings.
- However, erosion control practices are normally **enhanced** from those adopted on rural construction projects.

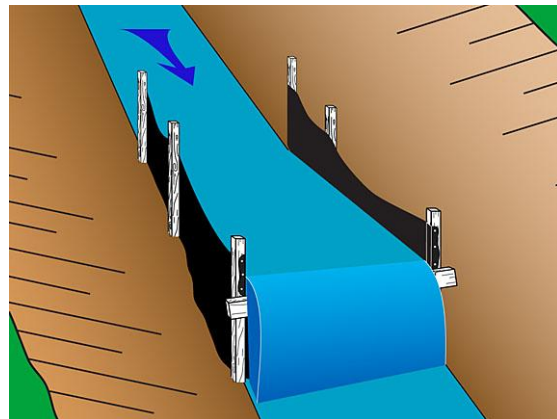


**Possible layout of erosion and sediment control measures on a single crossfall road**



Photo supplied by Catchments & Creeks Pty Ltd

**Check dam sediment trap**



**U-shaped sediment trap**



Photo supplied by Catchments & Creeks Pty Ltd

**U-shaped sediment trap on mild slope**



Photo supplied by Catchments & Creeks Pty Ltd

**U-shaped sediment trap on steep slope**

## Construction of a neighbourhood road

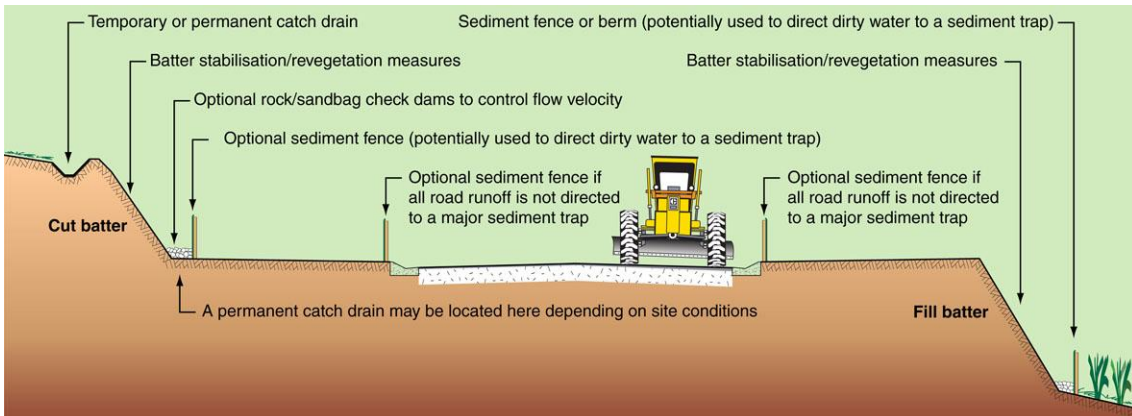


Photo supplied by Catchments & Creeks Pty Ltd

**Neighbourhood road**

## ESC practices on sub-arterial/arterial roads

- Sediment basins often appear within these larger construction projects at waterway crossings, especially if wide parklands exist adjacent to the waterway.
- Type 2 sediment traps can be used at drainage line crossings (sag points).
- Sediment controls often rely heavily on controlling inflows into kerb inlets.
- Ideally, berms and drains are used to direct dirty water to sediment traps rather than relying on sediment fences.



**Possible layout of erosion and sediment control measures on a crowned roadway**

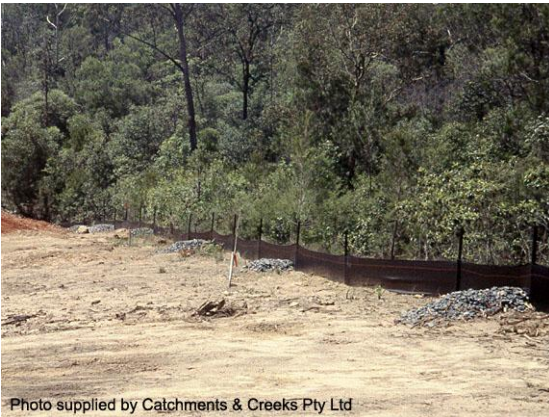


Photo supplied by Catchments & Creeks Pty Ltd

**Check dams adjacent a sediment fence**



Photo supplied by Catchments & Creeks Pty Ltd

**Mulch berm sediment barrier**



Photo supplied by Catchments & Creeks Pty Ltd

**'On-grade' kerb inlet sediment trap**



Photo supplied by Catchments & Creeks Pty Ltd

**'Sag' kerb inlet sediment trap**

## Construction of a dual carriageway

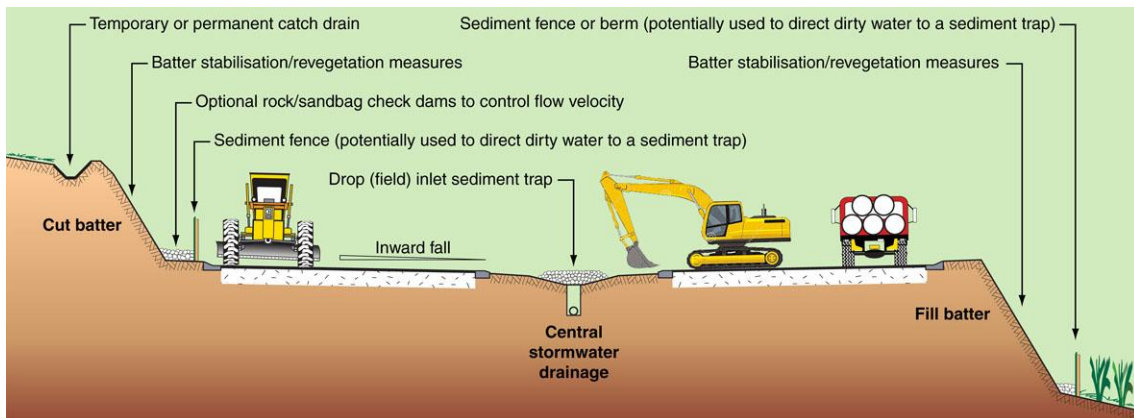


Photo supplied by Catchments & Creeks Pty Ltd

### Dual carriageway major road

### ESC practices on motorways & highways

- Sediment control practices rely heavily on the use of sediment basins.
- The use of sediment fences is avoided in favour of drainage controls directing dirty water to major sediment traps.
- Significant use is usually made of bank stabilisation measures prior to, or incorporated into, bank revegetation.
- Extensive use of mulch berms to control the movement of both 'clean' and 'dirty' water.



### Possible layout of erosion and sediment control measures on a dual carriageway



Photo supplied by Catchments & Creeks Pty Ltd

**Block & aggregate drop inlet sediment trap**



Photo supplied by Catchments & Creeks Pty Ltd

**Mesh & aggregate drop inlet sediment trap**



Photo supplied by Catchments & Creeks Pty Ltd

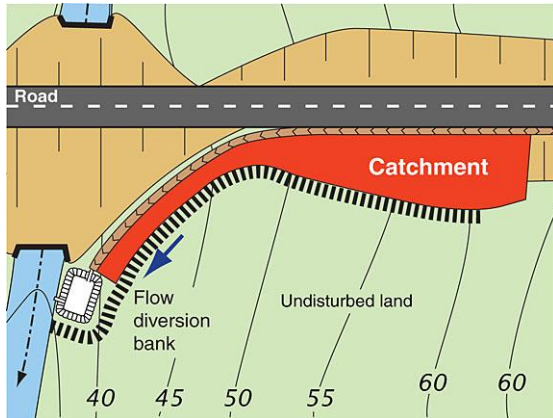
**Rock & aggregate drop inlet sediment trap**



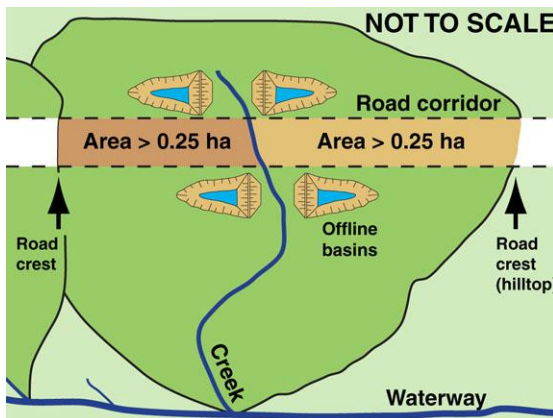
Photo supplied by Catchments & Creeks Pty Ltd

**Rock & aggregate drop inlet sediment trap**

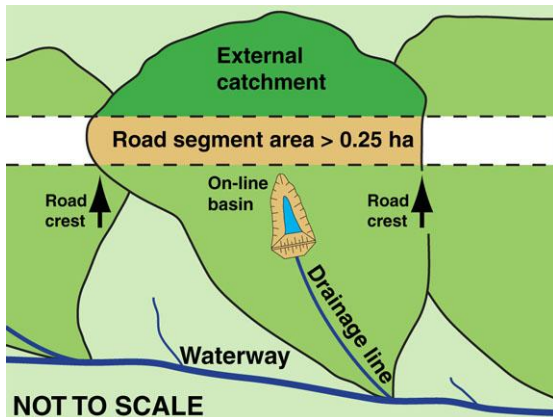
## Assessing the need for a sediment basin



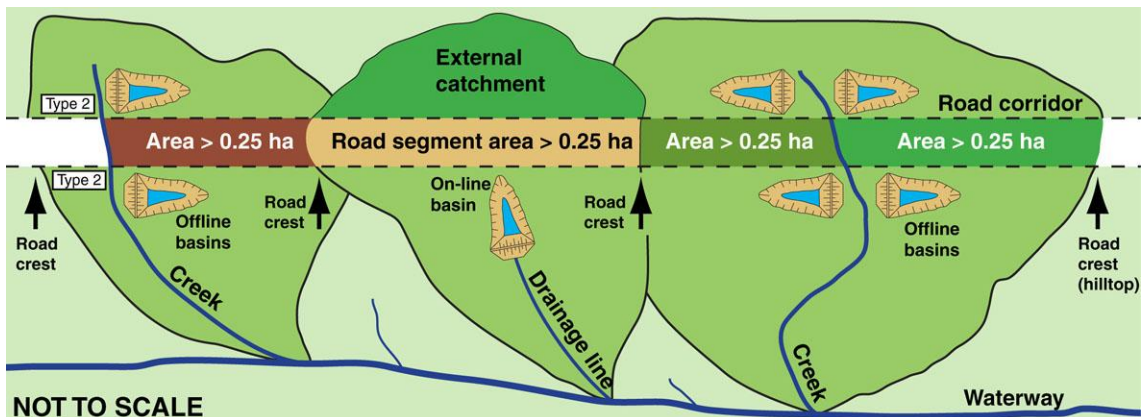
Clean water diversion around a basin



Offline sediment basins



On-line sediment basin



Road construction crossing several drainage catchments

### Terminology

- The full '**catchment**' is the total drainage area up-slope of a given location.
- Catchments can be divided into '**sub-catchments**' through the use of flow diversion banks and catch drains.
- The size of a sediment basin is based on the size of the drainage area that directly feeds into the basin; therefore the size of a basin can be minimised by:
  - diverting 'clean' water around the basin
  - locating basins 'offline', i.e. not on drainage lines or waterways.

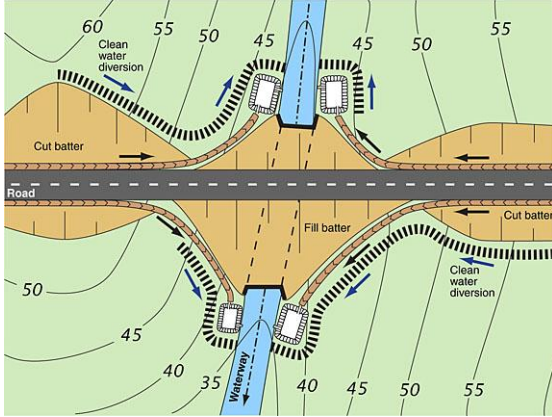
### Locations where up-slope run-on water can be diverted around the main sediment trap

- If the sediment trap **can** be located offline, (i.e. up-slope 'clean' water is diverted around the sediment trap) then:
  - a sediment basin is usually required if the sub-catchment area (hilltop to valley floor) connected to the sediment trap exceeds 0.25 hectares
  - a Type 2 or Type 3 control is usually sufficient if the sub-catchment area is less than 0.25 hectares.

### Locations where up-slope run-on water cannot be diverted around the main sediment trap

- If the main sediment trap **cannot** be located offline (i.e. both up-slope 'clean' water and construction site 'dirty' water runoff flow into the sediment trap) then:
  - a sediment basin (Type 1) is usually required if the road segment area (hilltop to hilltop) exceeds 0.25 hectares
  - however, the sediment basin must be designed to treat the full catchment area, including the external catchment.

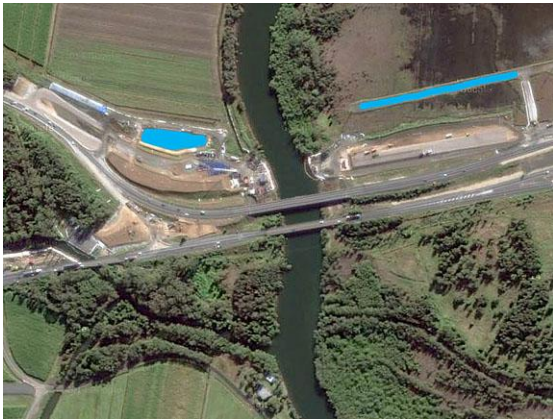
## Locating major sediment traps



**Culvert construction**

## Locating major sediment traps

- On road construction projects, major sediment traps are most commonly positioned in the following locations:
  - within those isolated areas of land formed by motorway access ramps
  - each side of the roadway, and each side of a watercourse crossing.
- Further discussion on the use and placement of sediment traps is provided in Part 2 of the Road Construction ESC field guide.



**Bridge construction**



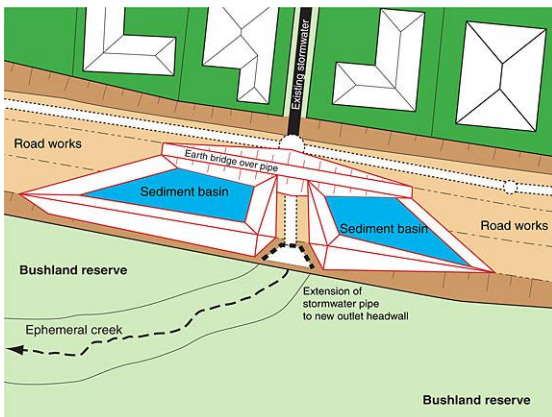
**Bridge construction**



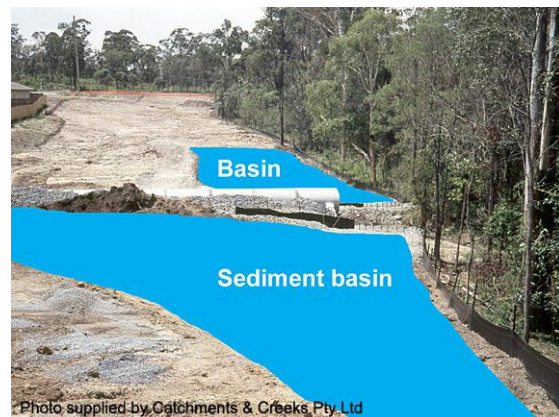
**Sediment basins on road construction**



**Basin located within a land-locked area**



**Road works over a pipe extension**



**Actual site conditions for diagram (left)**

## Case Study – Road construction over a piped drainage line

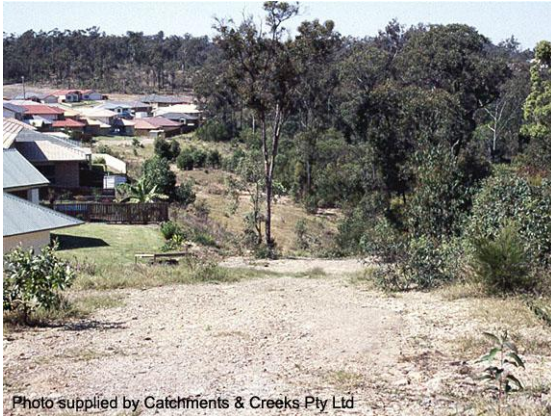


Photo supplied by Catchments & Creeks Pty Ltd

**Road reserve prior to road works**

### Project description

- This 1996 project involved one stage of a multi-stage urban road corridor.
- Construction involved significant cut and fill, and the crossing of a drainage line that required the extension of an existing pipe.
- The existence of the adjacent urban development meant that all sediment controls were located along the bushland side of the roadway.
- **Note; these ESC measures would not meet current 2024 design standards.**

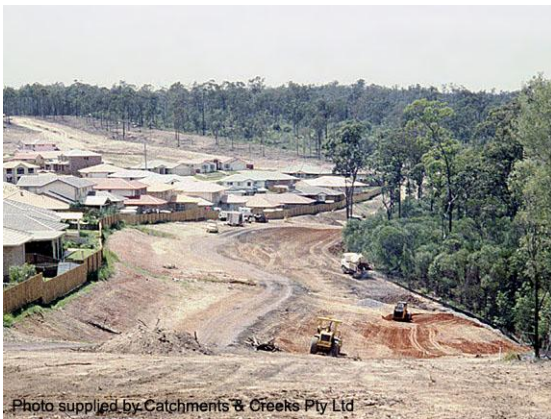


Photo supplied by Catchments & Creeks Pty Ltd

**Topsoil cleared from road reserve**

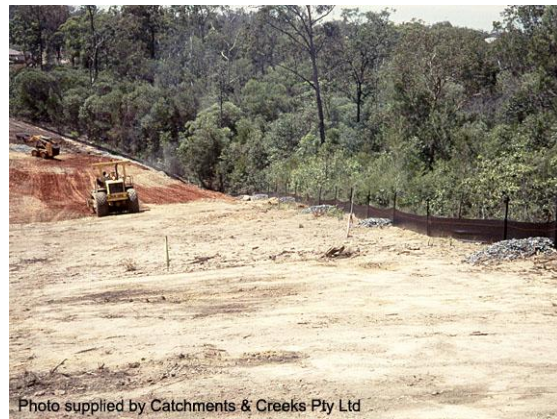


Photo supplied by Catchments & Creeks Pty Ltd

**Sediment fence with rock check dams**

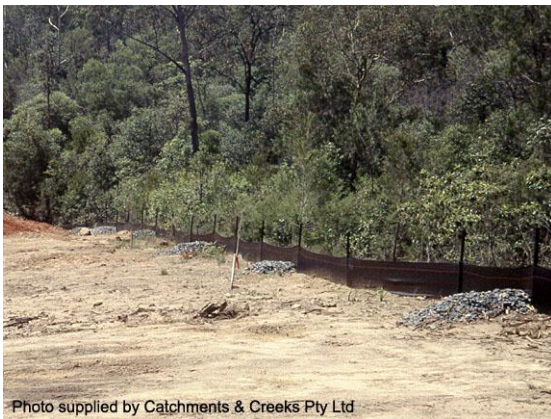


Photo supplied by Catchments & Creeks Pty Ltd

**Sediment fence with rock check dams**

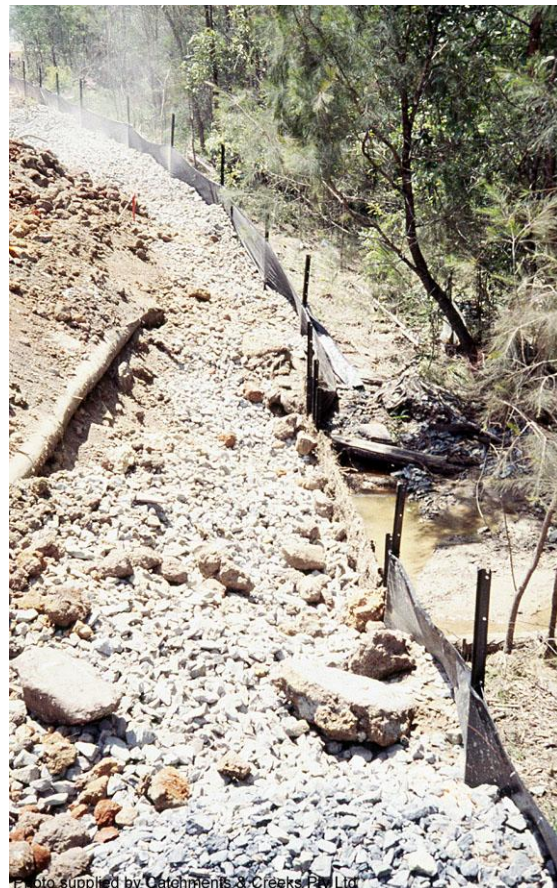


Photo supplied by Catchments & Creeks Pty Ltd

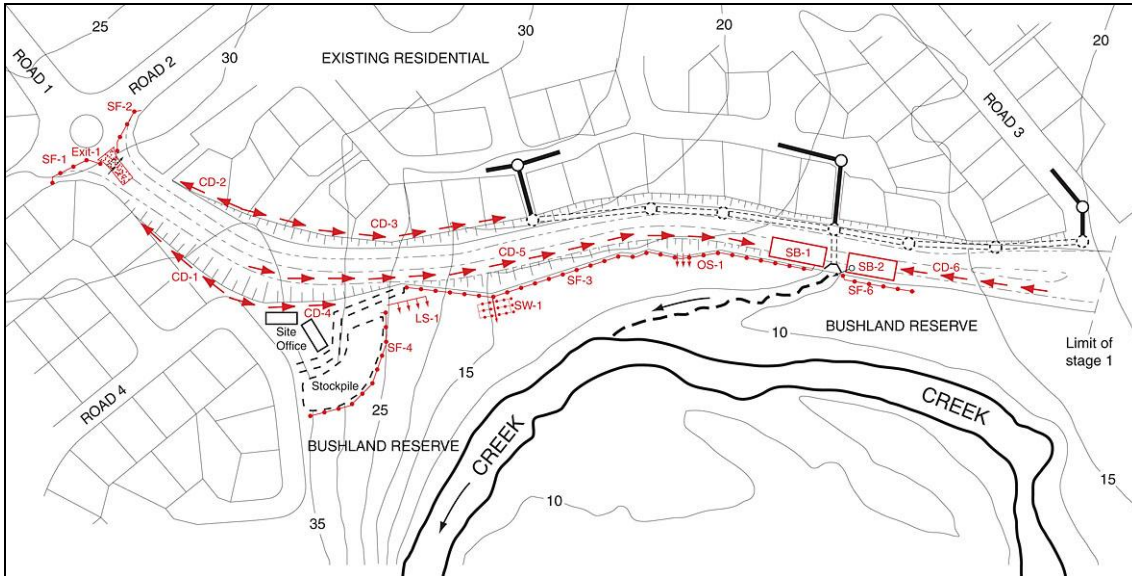
**Spill-through weir & aggregate filter**



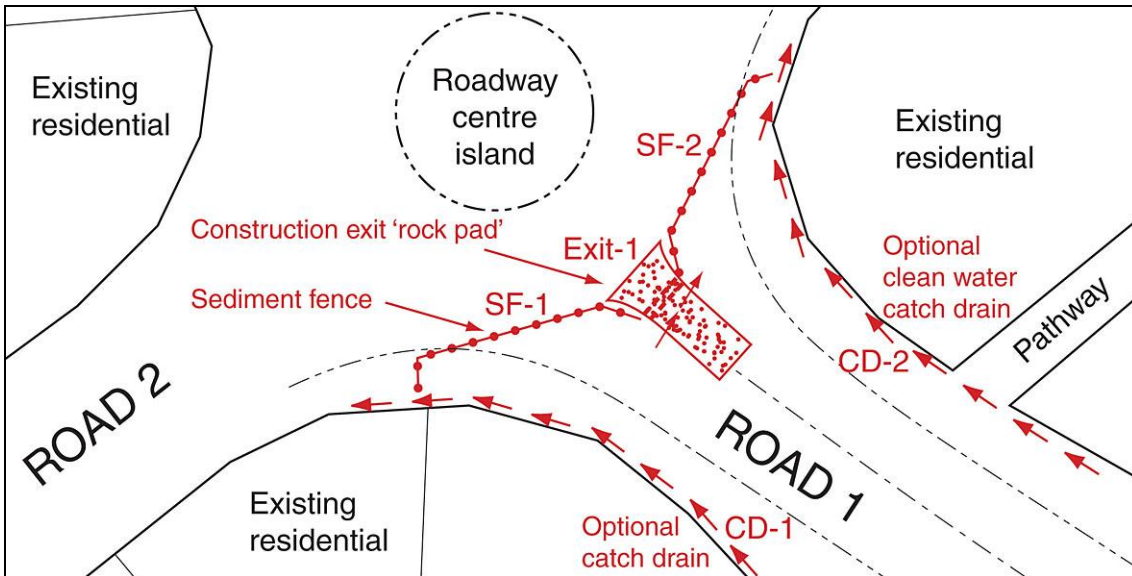
Photo supplied by Catchments & Creeks Pty Ltd

**Spill-through weir outlet structure**

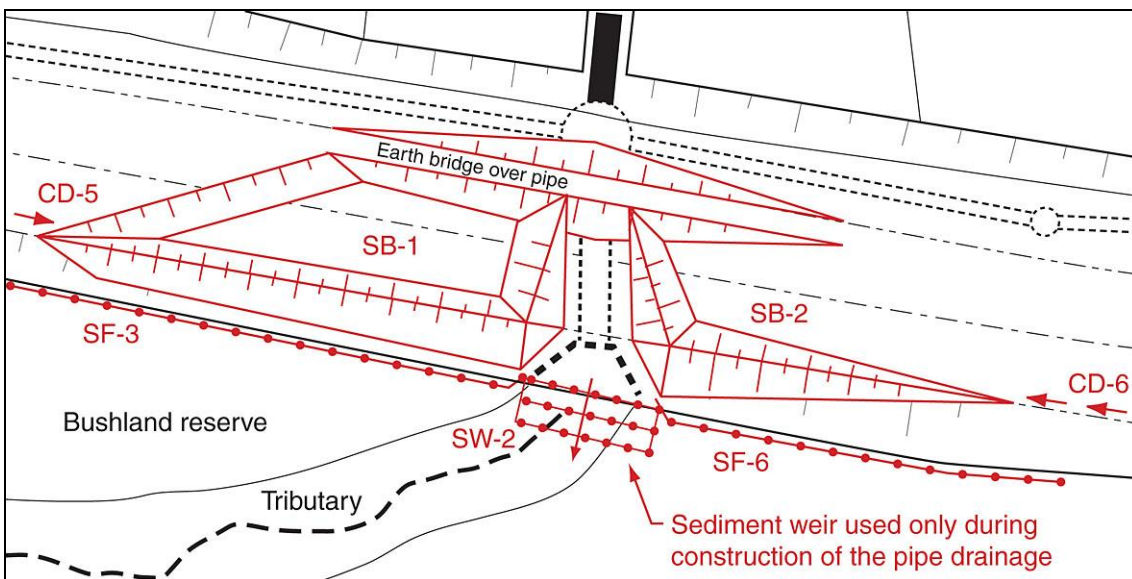
## Case Study – ESC Plans (1996 design standards)



**Stage 1 Erosion and Sediment Control Plan**



**Details of construction works ESCP at the road intersection**



**Details of construction works ESCP at the pipe extension**

## Case Study – Road intersection (1996 design standards)



Photo supplied by Catchments & Creeks Pty Ltd

**Pre-construction T-intersection**



Photo supplied by Catchments & Creeks Pty Ltd

**Heavy vehicle site entry point**



Photo supplied by Catchments & Creeks Pty Ltd

**Rock pad with flow diversion berm**



Photo supplied by Catchments & Creeks Pty Ltd

**Straw bale of questionable value!**

### Pre-construction condition

- Prior to the commencement of this stage of the road construction, the roadway corridor was partially cleared of vegetation, and the proposed mini roundabout consisted only of a T-junction.

### Site entry/exit point

- The site's main entry/exit point for heavy vehicles was located at the location of the proposed roundabout.
- A rock pad *Construction Exit* was installed.
- A raised flow diversion berm was formed within the rock pad consistent with the *Erosion and Sediment Control Plan*.
- The purpose of such berms is to divert sediment-laden runoff from the rock pad to a separate sediment trap (so that the rock pad does not become a source of sediment flow onto the public road).
- However, within the ESCP the location of the rock pad and adjacent sediment fences were marked in relation to the proposed roundabout, not the T-junction that currently existed.
- The consequences were:
  - the sediment fences were located in the positions marked within the ESCP
  - the rock pad was (correctly) re-positioned to abut with the existing T-junction
  - the flow diversion berm was positioned (incorrectly) such that it failed to divert excess stormwater runoff towards the sediment fences, and instead, simply diverted the flow around the berm and onto the public road.
- The 'correct' approach here would have been for the sediment fences and rock pad to be positioned as observed within the adjacent photos; however, for the raised flow diversion berm to have been located at the up-slope end of the rock pad such that sediment-laden run-on water would have been diverted towards one of the sediment fences.
- **The author does not know the original purpose of the straw bale!**

## Case Study – Drainage line crossing (1996 design standards)



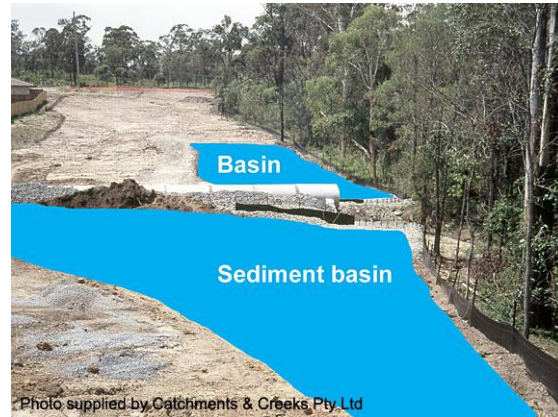
**Pipe outlet pre-construction**

### Drainage line crossing

- At the drainage line crossing, the following ESC measures were employed:
  - the piped drainage system was extended across the road corridor early in the construction phase
  - an earth bridge was built over the new pipeline to allow the movement of construction vehicles
  - sediment basins were formed each side of the extended pipeline.
- Restrictions prevented the basins from being built within the bushland area.



**Excavating a sediment basin**



**Location of sediment basins**



**Shallow Type-2 sediment basin**



**Rock filter dam outlet structure**



**Road construction corridor viewed from the eastern end of the project**

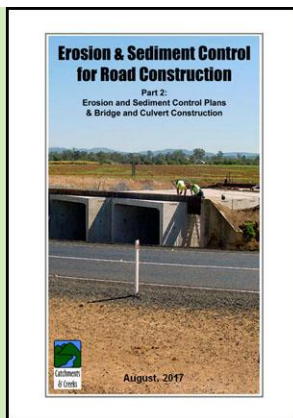
## **4. Culvert and Bridge Construction**

## Introduction



Photo supplied by Catchments & Creeks Pty Ltd

### Bridge construction (NSW)

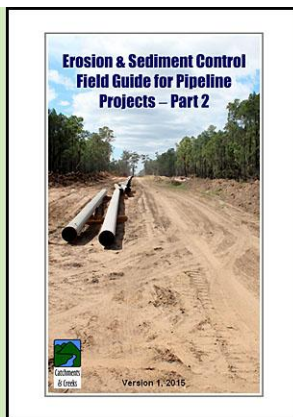


### Road Construction field guide, Part 2



Photo supplied by Catchments & Creeks Pty Ltd

### Culvert construction (Qld)



### Pipeline installation field guide, Part 2

## Introduction

- Waterway construction projects typically consist of:
  - bridge and arch construction
  - waterway culverts
  - pipeline crossings
  - dams and weirs
  - constructed lakes and waterways
- Unlike waterway maintenance, these construction projects usually take several months to complete.

## Bridge construction

- Expanded discussion on erosion and sediment control practices during the construction of roads, bridges and culverts can be found in a separate *Catchments and Creeks* field guide:
  - Erosion and Sediment Control for Road Construction (parts 1 and 2)
- Part 2 of this road construction field guide contains information on bridge and culvert construction.

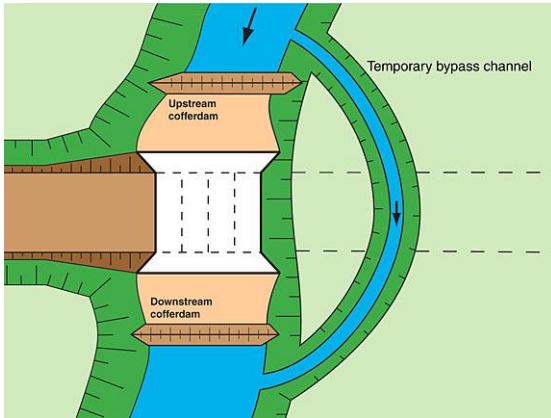
## Culvert construction

- Culvert designs include:
  - pipe culverts
  - box culverts
  - recessed culverts
- The construction of box culverts is complicated by the need to first form a base slab, which normally requires the temporary diversion of stream flows.
- Fish-friendly recessed culverts further complicate the issue by requiring deep excavation of the waterway bed.

## Pipeline crossings of waterways

- Expanded discussion on erosion and sediment control practices during the installation of pipelines can be found in a separate *Catchments and Creeks* field guide:
  - Erosion and Sediment Control Field Guide for Pipeline Projects (parts 1 & 2)
- Part 2 of this field guide contains information on the construction of pipeline crossings across drainage lines and waterways.

## Issues



Temporary bypass channel

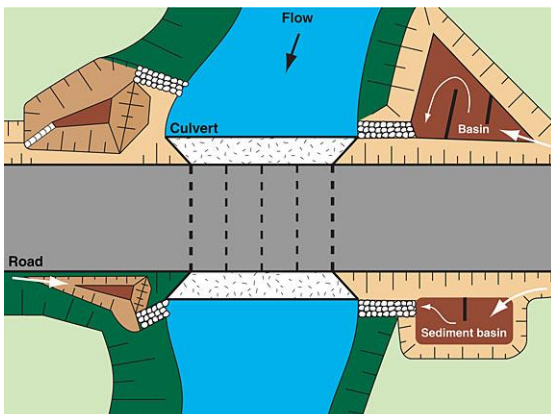


Fish migration



Photo supplied by Catchments & Creeks Pty Ltd

Construction of a culvert base slab



Sediment control practices

### Maintaining stream flows

- If base flows within the waterway are significant, then it is common for the waterway crossing to consist of a bridge rather than a culvert.
- If a culvert is to be constructed across such a waterway, then traditional construction practice would normally have involved the construction of a temporary bypass channel.
- However, such bypass channels may not provide suitable fish passage conditions.

### Maintaining fish passage

- Fisheries authorities often give approval for the short-term interruption of general fish passage conditions within a waterway to allow construction activities.
- However, 'fish migration' and 'fish passage' are often viewed as two separate issues.
- Fish migration is a specific type of fish movement that is critical to the life cycle of certain fish species, and if construction activities are to occur during such periods, then strict rules can apply.

### Construction difficulties

- The following construction procedures should not be considered as normal construction practice—these procedures are complex, difficult, expensive, and in some cases, may be impractical.
- Creditable advice must be obtained from experienced construction personnel prior to adopting any of the following construction procedures.
- The 'staged' construction of a culvert will require a re-design of the culvert, including the concrete reinforcing.

### Sediment control practices

- Sediment basins have not been shown in the following two case studies in order to avoid the figures looking too complex.
- In each case, sediment basins would normally be located on each side of the roadway and each side of the waterway (as shown left).

## Site issues that can influence the construction procedure



Photo supplied by Catchments & Creeks Pty Ltd

**Culvert construction**

### Construction procedure

- There is more than one way to build a culvert, causeway or bridge.
- The method of construction can be influenced by many factors, including:
  - available funds
  - the type of structure
  - flow conditions within the waterway
  - fish passage requirements
  - land use adjacent to the structure
  - the existing road structure and the need to maintain traffic flow.



Photo supplied by Catchments & Creeks Pty Ltd

**Culvert construction in a dry channel**

### Stream flow conditions

- The construction procedure is critically dependent on the expected stream flows.
- The construction of a base slab is obviously much easier and cost effective if the works are scheduled for periods when ephemeral streams are either:
  - wet but not flowing (trench de-watering will be required), or
  - dry (preferred condition).



Photo supplied by Catchments & Creeks Pty Ltd

**Elevated stream flow conditions**

### The risk of elevated stream flows

- Elevated stream flows can result from local or distant rainfall.
- Many parts of Australia experience only seasonal rainfall and stream flows, so different construction procedures will need to be employed during the dry and wet seasons.
- The methods for flow bypassing vary depending on the expected stream flow.

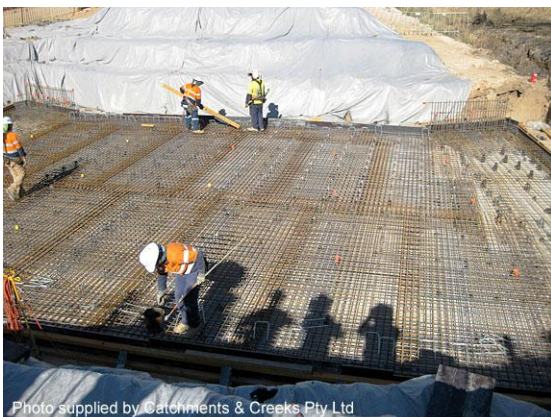


Photo supplied by Catchments & Creeks Pty Ltd

**Construction of a culvert base slab**

### The need for bed disturbance

- Bridge and arch construction has the advantage of requiring minimal disturbance to the bed of the waterway.
- Pipe culverts also have the advantage of reduced bed disturbance (relative to box culverts); however, the waterway bed still needs to be isolated from stream flows.
- The construction of box culverts requires the construction of a base slab, which requires the bed to be isolated from stream flows.

## Road construction across a drainage line (non-waterway)

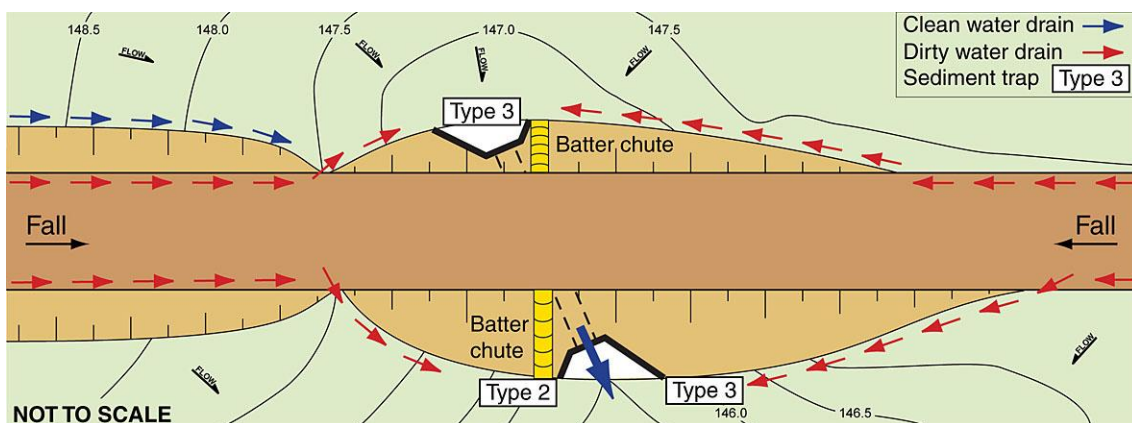


Photo supplied by Catchments & Creeks Pty Ltd

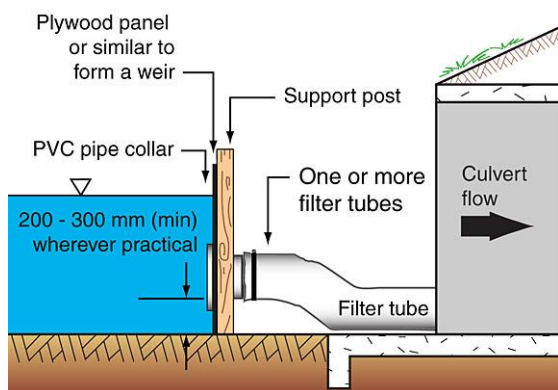
### Sediment fence (Type 3 sediment trap)

#### Treatment option 1

- Placement of a Type 3 sediment trap across the **entrance** of a small drainage pipe (culvert) is appropriate when:
  - total up-slope catchment (clean & dirty) is less than 0.25 ha, and
  - soil loss rate < 75 t/ha/yr.
- Typical Type 3 sediment traps include:
  - Sediment fence with wire mesh backing
  - U-shaped sediment trap.



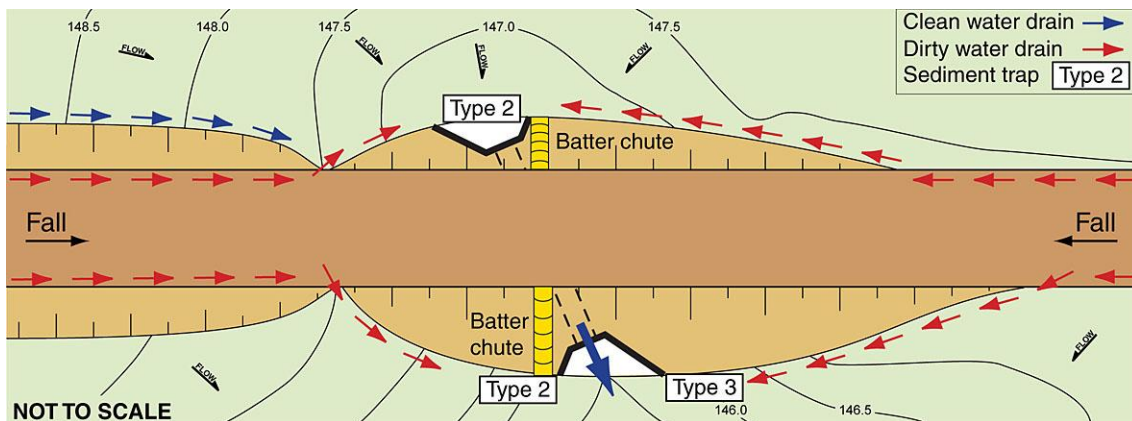
### Example ESC measures for road works over a drainage line with minimal catchment area



### Filter tube dam (Type 2 sediment trap)

#### Treatment option 2

- Placement of a Type 2 sediment trap across the **entrance** of a small drainage pipe (culvert) is appropriate when:
  - total up-slope catchment (clean & dirty) is less than 0.25 ha, and
  - soil loss rate < 150 t/ha/yr.
- Typical Type 2 sediment traps include:
  - Block & aggregate sediment traps
  - Filter tube dams
  - Mesh & aggregate sediment traps
  - Sediment weirs.



### ESC measures for road works over a drainage line with modest up-slope catchment area

## Road construction across a drainage line (non-waterway)

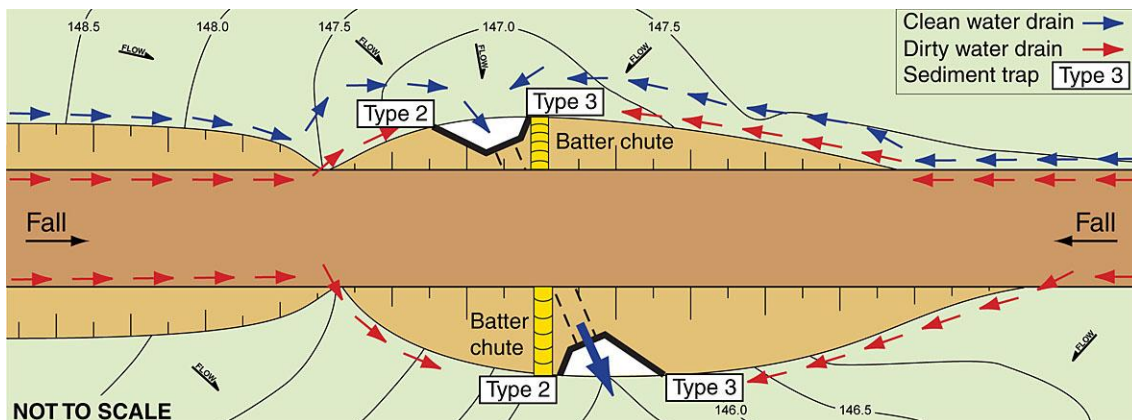


Photo supplied by Catchments & Creeks Pty Ltd

**Rock filter dam (Type 2 sediment trap)**

### Treatment option 3

- Placement of Type 2 sediment traps **each side of the entrance** of a small drainage pipe (culvert) is appropriate when:
  - the contributing catchment area is less than 0.25 ha and the soil loss rate is greater than 75 t/ha/yr, **OR**
  - the contributing catchment area is greater than 0.25 ha and the soil loss rate is less than 150 t/ha/yr.
- Use of Type 3 sediment traps is appropriate when the area < 0.25 ha and the soil loss rate < 75 t/ha/yr.



**ESC measures for road works over a drainage line with significant up-slope catchment**

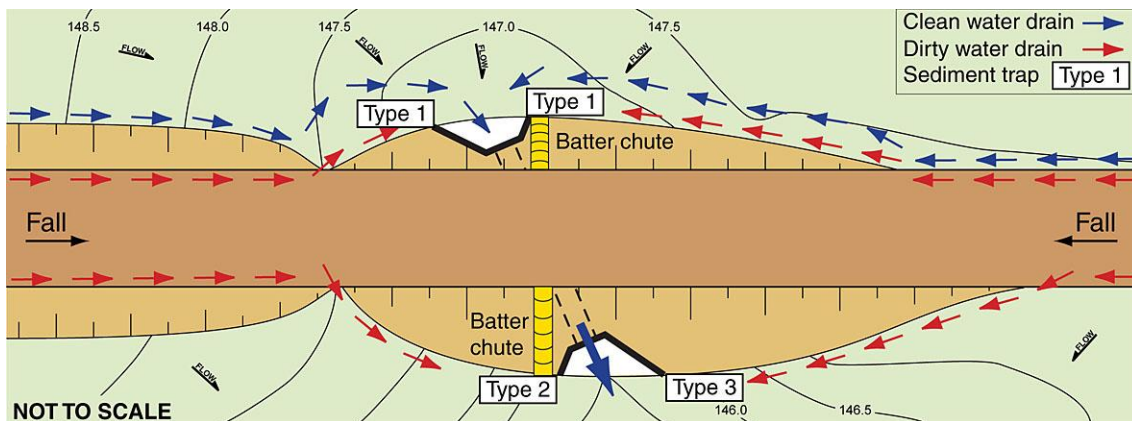


Photo supplied by Catchments & Creeks Pty Ltd

**Sediment basins (Type 1 sediment trap)**

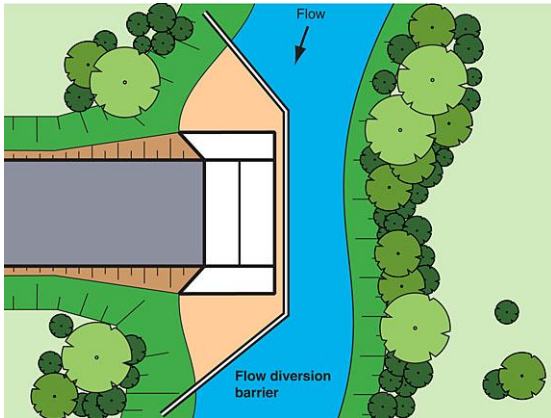
### Treatment option 4

- Placement of Type 1 sediment traps **each side of the entrance** of a small drainage pipe (culvert) is appropriate when:
  - the contributing catchment area is greater than 0.25 ha, or
  - soil loss rate > 150 t/ha/yr.
- Not all of the clean and dirty water drains shown below will be operational during each phase of the road construction.
- The contributing catchment area includes both the road and batter runoff areas as appropriate.



**ESC measures for road works over a drainage line with significant road runoff area**

## Site issues that can influence the crossing of waterways



Staged construction of a culvert



Photo supplied by Catchments & Creeks Pty Ltd

Freshwater fish migration



Photo supplied by Catchments & Creeks Pty Ltd

Temporary bypass road



Photo supplied by Catchments & Creeks Pty Ltd

Temporary stream crossing

### Maintaining stream flows

- If it is necessary to maintain stream flows during the construction period, then it may be necessary to construct the culvert in stages isolated from stream flows through the use of impervious 'isolation barriers'.
- Constructing culverts in stages while maintaining stream flows is a complex and expensive procedure that should only be considered in exceptional circumstances.
- The use of a bridge, instead of a culvert, is preferred in these circumstances.

### Maintaining fish passage

- Potential impacts on fish passage can vary significantly across the country.
- The best option is to approach the local Fisheries office for guidance on fish passage sensitivity and the critical periods of fish migration.
- Some states may have specific legislation or construction codes.
- Issues include: time of year, duration of works, the extent of the fish barrier, and proposed bank rehabilitation measures.

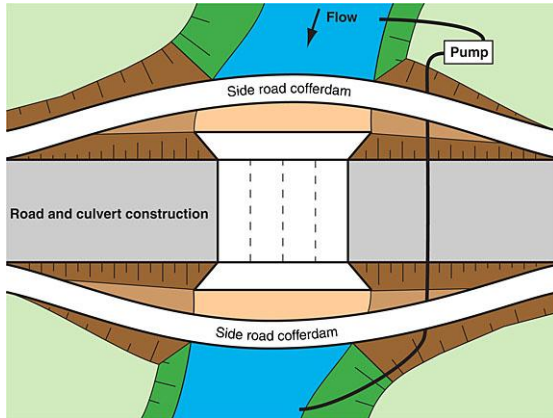
### Maintaining public access across the waterway

- Bridge and culvert construction is often preceded by the construction of a temporary bypass road to allow ongoing traffic movement.
- The fish passage requirements for these temporary structures can vary significantly from location to location.

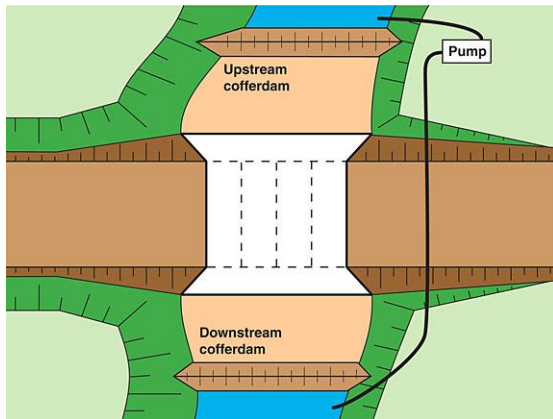
### Construction of temporary bypass roads

- A temporary stream crossing may also be needed to allow the movement of construction vehicles across the waterway.
- Temporary stream crossings may consist of:
  - piped culvert
  - culvert 'bridging slab'
  - ford crossing (alluvial streams).
- The use of temporary stream crossings is discussed later in this field guide.

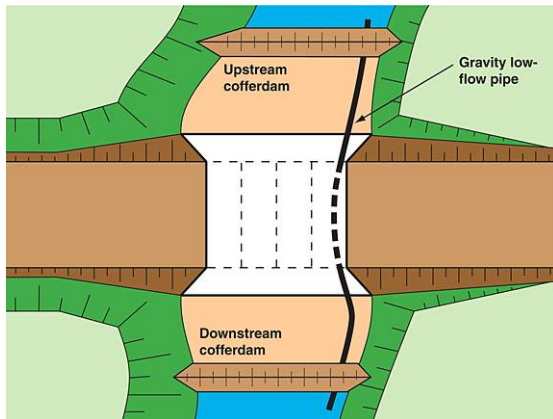
## Use of cofferdams



**Bypass roads used as cofferdams**



**Cofferdams with pumped bypass**



**Cofferdams with gravity flow bypass**



**Instream works with piped-flow bypass**

## Use of cofferdams

- Cofferdams are commonly used to isolate a section of a waterway.
- Cofferdams can be formed from a variety of materials, including:
  - sandbags
  - earth
  - water-filled rubber dams
  - sheet piling.
- Cofferdams can also operate as temporary bypass traffic lanes.

## Cofferdams with pumped bypass

- Flow bypassing is most commonly achieved using a pump.
- These pumps need ongoing maintenance (fuel supply, removal of blockages) during their operation (including non-work days).
- Bypass pump hoses can interfere with the construction process.
- Pumps can be blocked or damaged by natural sediment flows during flood events.

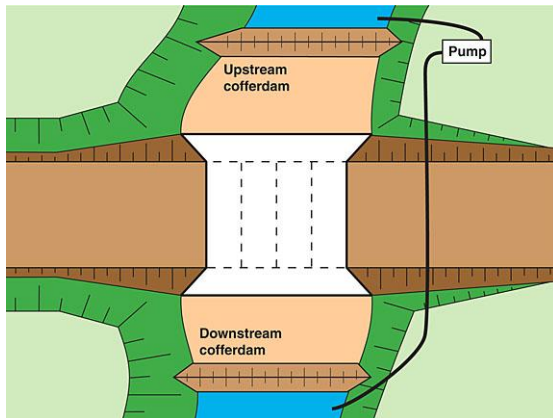
## Cofferdams with gravity flow bypass

- If the waterway contains significant base flows, then a large-pipe gravity system may be preferable (see image below in which bypass flows are contained within a large, relocatable steel pipe).
- These in-channel bypass pipes can interfere with the construction process.
- Both pumped and gravity systems will result in significant short-term impacts on fish passage during the construction period.

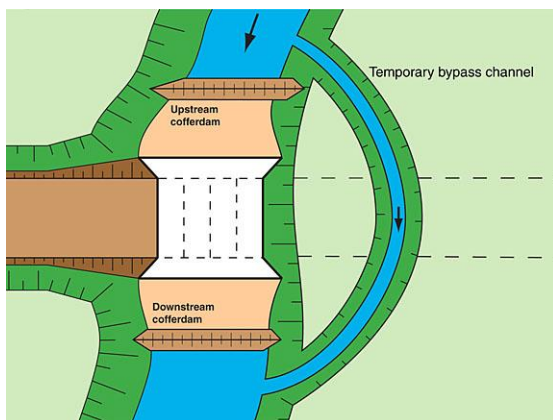
## Other design issues

- A de-watering system will usually be needed to manage both groundwater and local stormwater inflows.
- Floodgates can be incorporated into the cofferdam to allow the work area to drain in the event of heavy local rainfall or elevated stream flows.
- Working in tidal waterways can introduce additional complexities with different state legislation being applied to works within tidal waters.

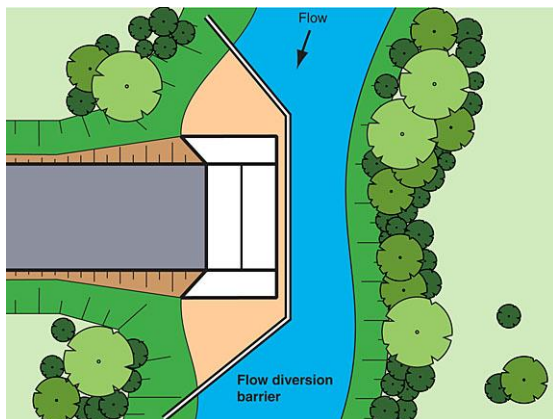
## Culvert construction



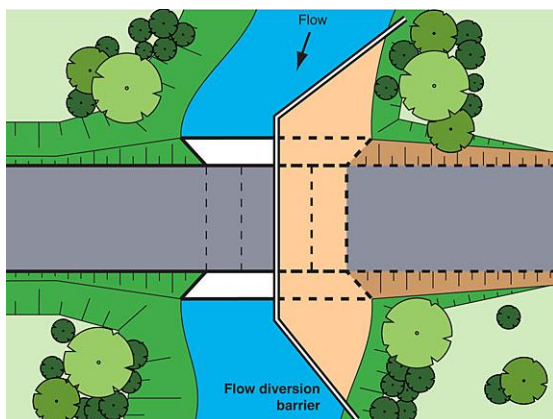
Use of cofferdams



Construction of a bypass channel



Stage 1



Stage 2

### Cofferdam usage

- The degree of complexity of the culvert construction increases significantly if it is necessary to maintain stream flows, fish passage, and/or public access during the construction phase.
- Stream flows can be maintained by:
  - providing a pumped bypass
  - installing a gravity-flow pipeline that can be easily relocated
  - constructing a bypass channel
  - staging the instream disturbance.

### Bypass channels

- If base flows within the waterway are significant, then it is preferable for the waterway crossing to consist of a bridge rather than a culvert.
- If a culvert is to be constructed across such a waterway, then the construction practice may involve the construction of a temporary bypass channel.
- However, such bypass channels may not provide suitable fish passage conditions.

### Staged construction

- The staging of a culvert construction is not currently considered normal practice because of the construction difficulties and expense.
- Advice on the practicality of such construction methods must be obtained from experienced personnel prior to adopting such a construction process.
- The 'staged' construction of a culvert will likely require a re-design of the base slab reinforcing.
- Such complex construction practices can be avoided by:
  - constructing bridges or arch structures over critical fish habitats
  - constructing culverts during the dry season
  - constructing culverts during periods when fish are not migrating along the waterway
  - considering the option of a pipe culvert instead of a box culvert.

## Fish passage considerations



### Freshwater fish migration



### Signage at in-stream works



### Retention of tree root system



### Natural bank vegetation

### Fish passage

- Fish passage considerations and management strategies need to be discussed with the local Fisheries office.
- Some states may have specific legislation or self-assessable codes that address issues such as:
  - the maximum allowable duration of in-stream works and the existence of temporary fish barriers
  - the time of year when works can occur
  - required bank rehabilitation measures.

### Notification and signage of works

- Requirements for on-site signage of approved works vary across the country.
- In some states, all in-stream works will require both pre-works and post-works notification with the local Fisheries office.
- In Queensland such requirements also apply to works conducted under their self-assessable codes.
- It is important to note how rules can change during periods of 'fish migration' as compared to general 'fish passage'.

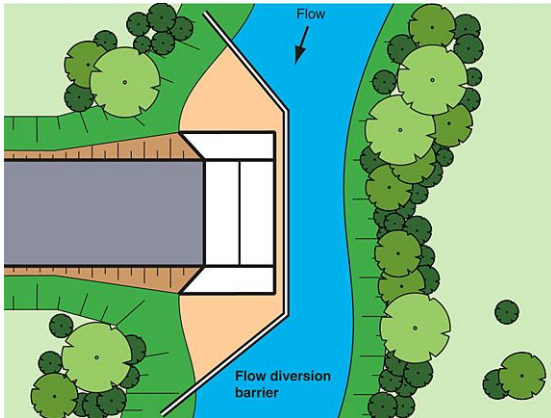
### Vegetation clearing on bed and banks

- If it is necessary to remove vegetation (marine, aquatic or riparian) from the bed and banks; then wherever practical, this vegetation should be cut no lower than ground level, with the roots left in the ground to aid soil stabilisation.
- Ideally, roots should only be removed within the region of hard engineering works.
- In reality, the application of environmental requirements such as this will vary from site to site.

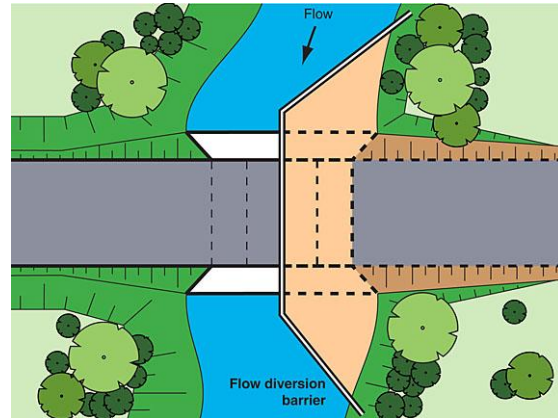
### Bank rehabilitation

- In some cases it may be a requirement to re-establish natural vegetation cover over the channel's bed and banks.
- However, this may not be appropriate with respect to establishing vegetation under a bridge deck, or integrating vegetation with the required abutment and bank stabilisation measures.
- It is important to understand how certain plants can assist in providing beneficial fish passage conditions under a bridge.

## Culvert construction using isolation barriers (Examples 1 & 2)



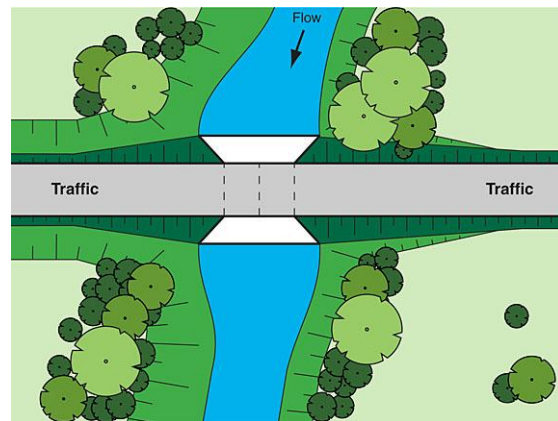
**Example 1 – Stage 1 of construction**



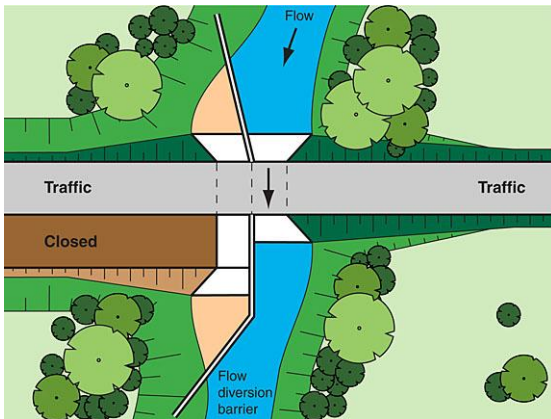
**Stage 2 of new culvert construction**

### Example 2 – Culvert expansion

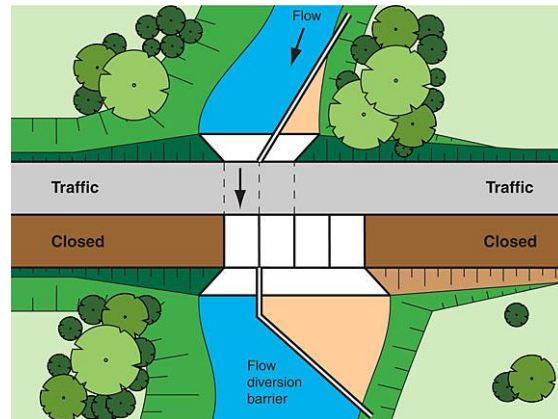
- The degree of complexity and construction difficulties increase significantly if it is necessary to maintain stream flows, fish passage, and/or public access.
- Construction difficulties include:
  - providing a watertight seal on the isolation barriers
  - attaching the isolation barriers to the culvert
  - constructing the culvert aprons.



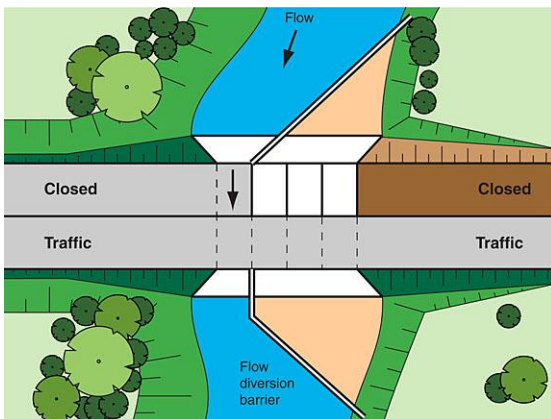
**Example 2 – Existing culvert**



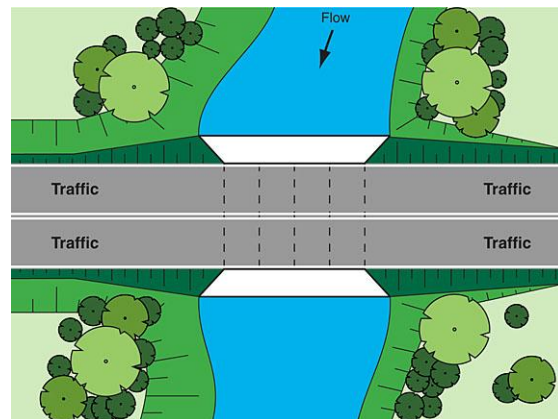
**Example 2 – Stage 1**



**Example 2 – Stage 2**



**Example 2 – Stage 3**



**Finished waterway culvert**

## Types of isolation barriers



Photo supplied by Catchments & Creeks Pty Ltd

**Sheet piling isolation barrier**

### Sheet piling

- Steel sheet piling is a traditional type of instream isolation barrier.
- This technique can be used in relatively deep water.



Photo adapted from Aqua-Barrier, USA

**Water-filled dams**

### Transportable water-filled dams

- Transportable water-filled dams can be used to isolate large, shallow-water areas at low cost.
- Generally limited to relatively wide and shallow waterways.



Photo supplied by Catchments & Creeks Pty Ltd

**Earth bund**

### Earth bunding

- Significant sediment disturbance can occur during installation and removal of the earth bunds.
- Earth bunds (isolation barriers) can only be used in low velocity waterways, and only during the dry season when elevated stream flows are unlikely to occur.
- The earth bunding must be appropriately stabilised, and if necessary, covered with filter cloth.
- Note; topsoil is usually more stable than a subsoil.

### Aqua Barrier

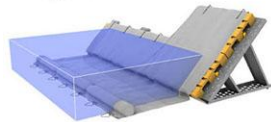


Photo by Aqua-Barrier



**A-frame Aqua Barrier**

### A-frame water barriers

- Various commercial products are available.
- These techniques are generally limited to shallow water bodies.
- Possibly best used when working within concrete lined drainage channels.

### Example 3 – Culvert construction with public bypass road

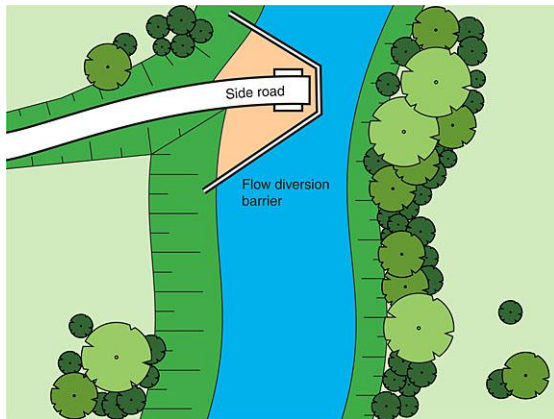


Photo supplied by Catchments & Creeks Pty Ltd

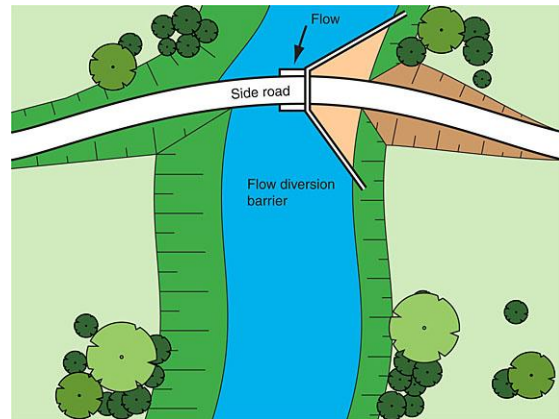
Temporary bypass road

#### Use of temporary bypass roads

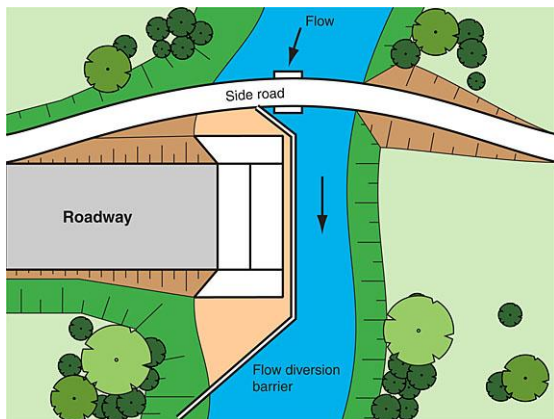
- In certain circumstances, the culvert placed under the temporary bypass road will also need to be fish friendly (consult with the local Fisheries officer).
- Construction difficulties include:
  - providing a watertight seal on the isolation barriers
  - constructing the culvert aprons
  - providing suitable fish passage through the temporary road culvert (if required).



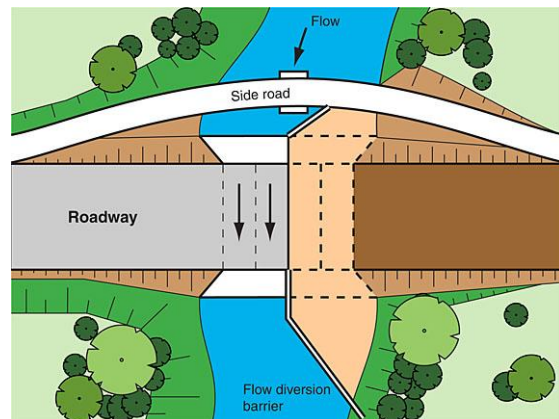
Stage 1



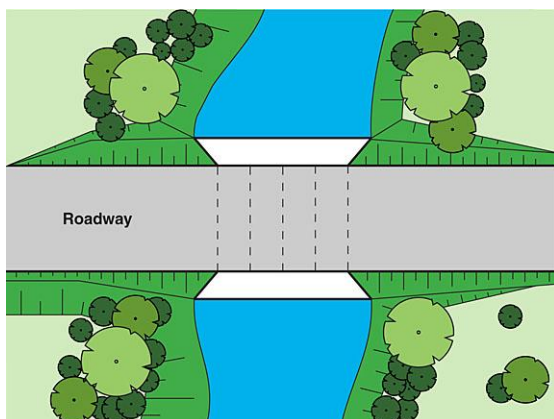
Stage 2



Stage 3



Stage 4



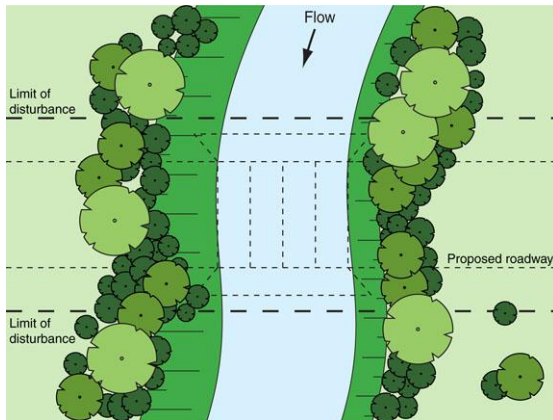
Stage 5



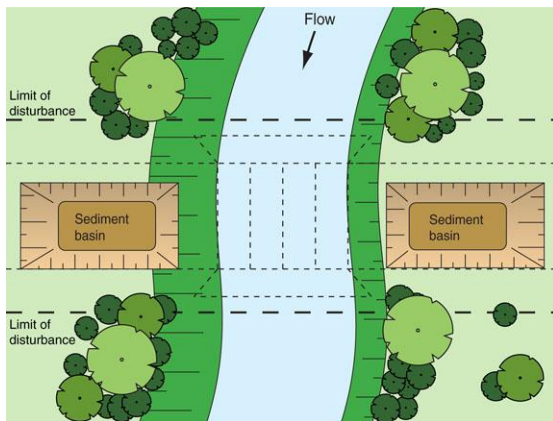
Photo supplied by Catchments & Creeks Pty Ltd

Temporary bypass road

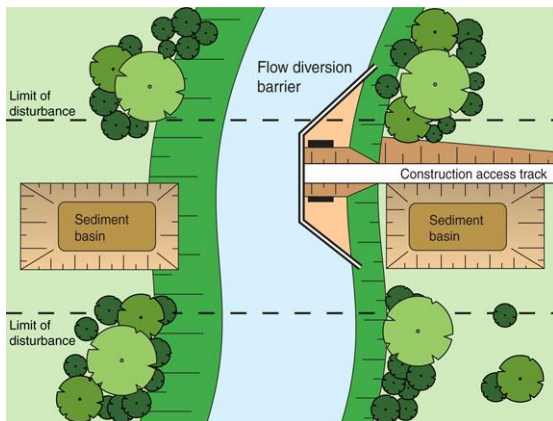
## Example 4 – Sediment basins located within the road corridor



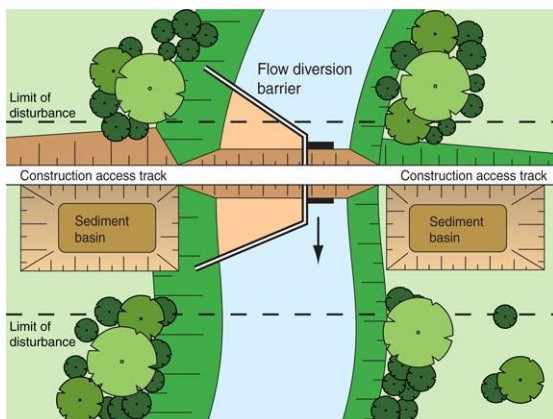
Pre-construction waterway



Stage 1



Stage 2



Stage 3

### Example 4

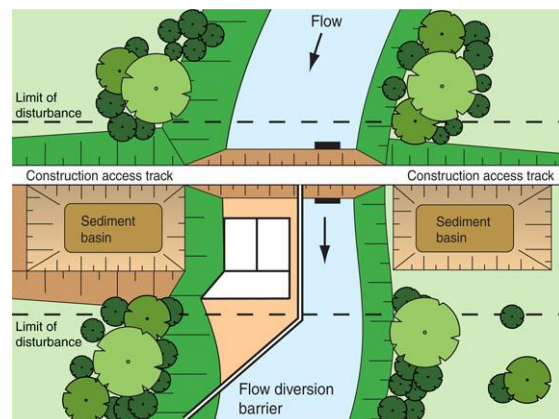
- This construction procedure represents one of the most complex construction scenarios.
- Construction difficulties include:
  - providing a watertight seal on the isolation barriers
  - directing all sediment-laden water to the sediment basins
  - ensuring the existence of the sediment basins does not adversely affect the long-term stability of the pavement foundations.

### Locating sediment basins

- Ideally, the width of the road corridor should be expanded at waterway crossings to allow sediment basins to be constructed to the side of the embankment.
- Alternatively, negotiations can occur with the adjacent land owners to allow the temporary use of their land for the construction of temporary sediment basins—possibly resulting in the delivery of a permanent farm dam.

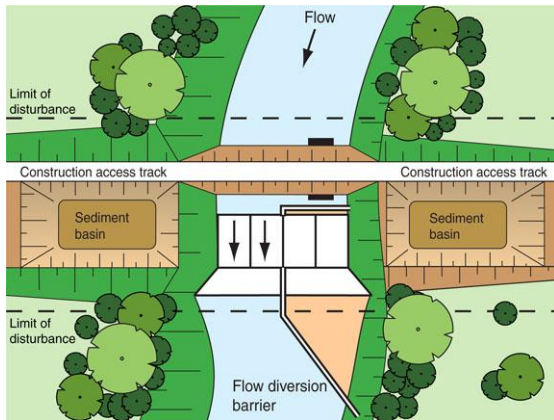
### Locating sediment basins within the road corridor

- Locating sediment basins within the envelope of a proposed road embankment can introduce several construction difficulties, including:
  - possible additional expenditure of revised geotechnical specifications
  - possible rejection of the construction practice by the geotechnical consultant
  - strict supervision of the de-silting of the basins prior to forming the road embankment.

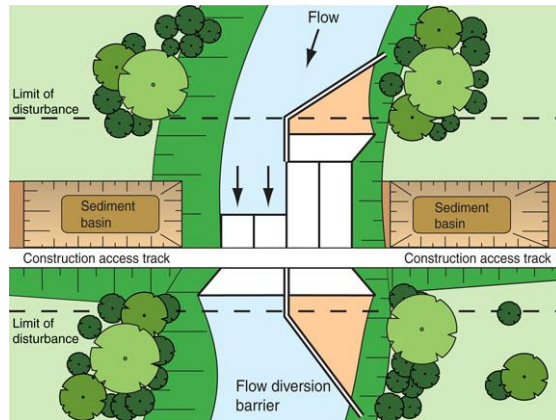


Stage 4

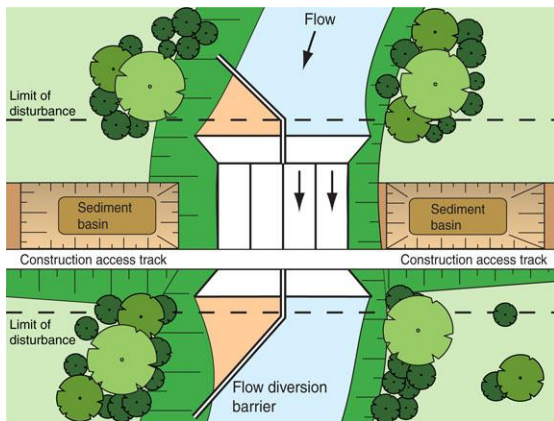
## Example 4 (continued)



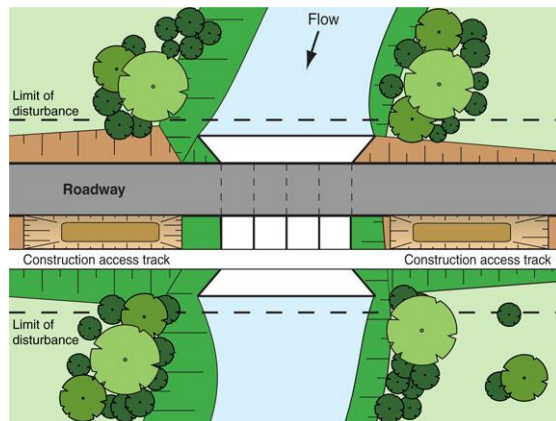
**Stage 5**



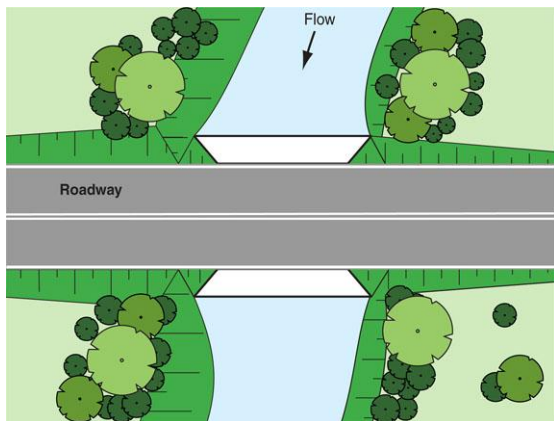
**Stage 6**



**Stage 7**



**Stage 8**



**Finished roadway**

### Avoid complex construction practices

- Complex construction practices, such as those described above, can be avoided by:
  - constructing bridges or arch structures over critical fish habitats
  - constructing culverts during the dry season
  - constructing culverts during periods when fish are not migrating along the waterway
  - considering the possible benefits of using a pipe culvert instead of a box culvert.



Photo supplied by Catchments & Creeks Pty Ltd

**Bridge**



Photo supplied by Catchments & Creeks Pty Ltd

**Arch bridge**

## Sediment controls for road construction over waterways

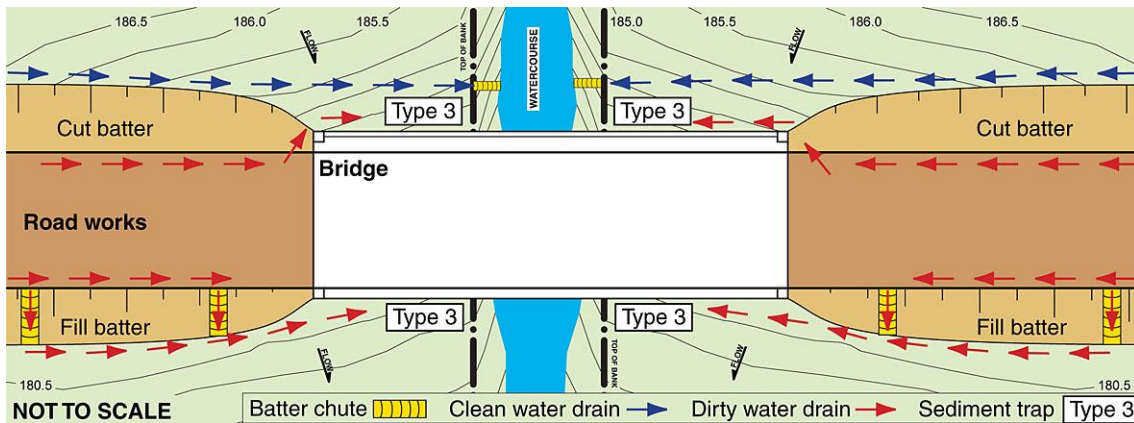


Photo supplied by Catchments & Creeks Pty Ltd

### Sediment fence (Type 3 sediment trap)

#### Type 3 sediment controls

- The use of a Type 3 sediment trap is appropriate when:
  - total up-slope catchment (clean & dirty) is less than 0.25 ha, and
  - soil loss rate < 75 t/ha/yr.
- Typical Type 3 sediment traps include:
  - Sediment fence
  - U-shaped sediment traps



### ESC measures for road works over a waterway with minimal road runoff catchment

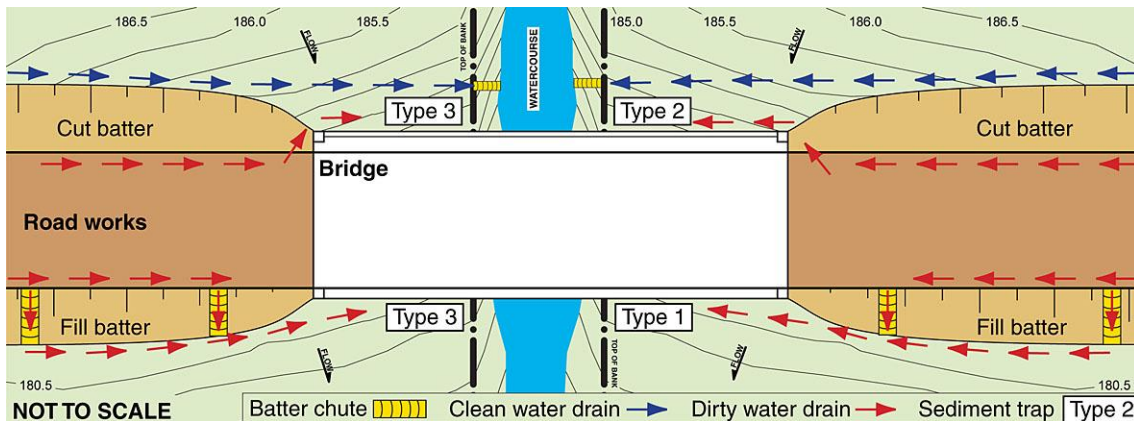


Photo supplied by Catchments & Creeks Pty Ltd

### Rock filter dams (Type 2 sediment trap)

#### Type 2 sediment controls

- Placement of Type 2 sediment traps each side of a bridge or culvert construction is appropriate when:
  - the contributing catchment area is less than 0.25 ha and the soil loss rate is greater than 75 t/ha/yr, OR
  - the contributing catchment area is greater than 0.25 ha and the soil loss rate is less than 150 t/ha/yr.
- Differences in the sub-catchment areas could mean different sediment traps are required in each quadrant.



### ESC measures for road works over a waterway with variable catchment areas

## Sediment controls for road construction over waterways

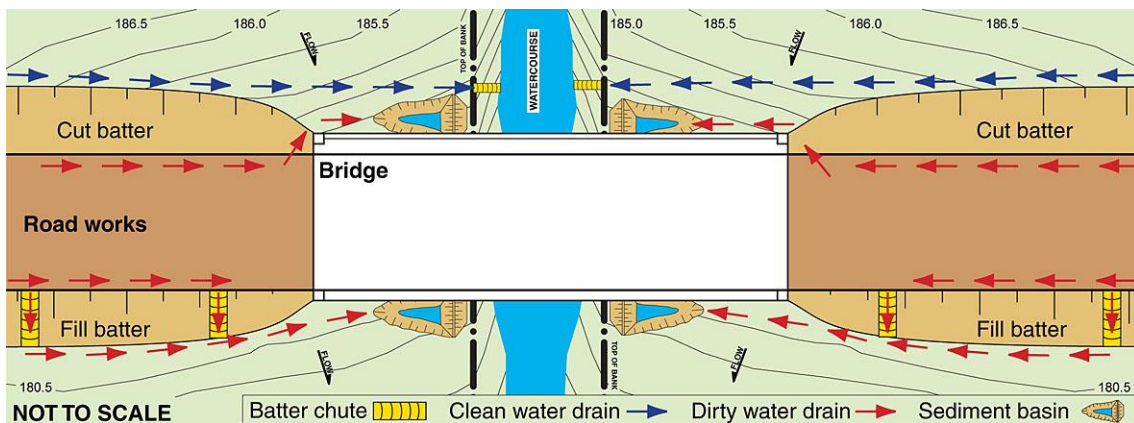


Photo supplied by Catchments & Creeks Pty Ltd

### Type 1 sediment controls

- Placement of Type 1 sediment traps each side of a bridge or culvert construction is appropriate when:
  - the contributing catchment area is greater than 0.25 ha, or
  - soil loss rate > 150 t/ha/yr.
- Not all of the clean and dirty water drains shown below will be operational during each phase of the road construction.
- The contributing catchment area can include both the road and batter runoff.

### Sediment basins (Type 1 sediment trap)



### ESC measures for road works over a waterway with significant dirty water runoff

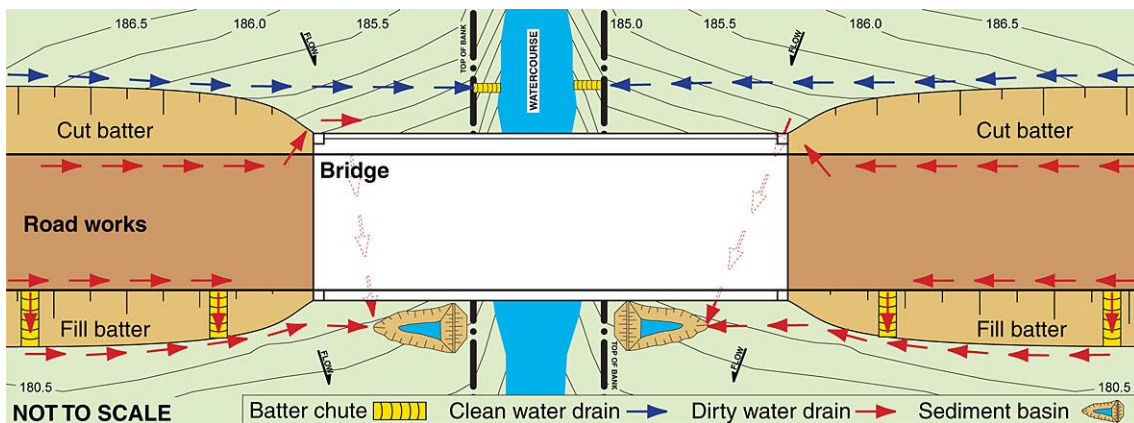


Photo supplied by Catchments & Creeks Pty Ltd

### Alternative drainage layouts

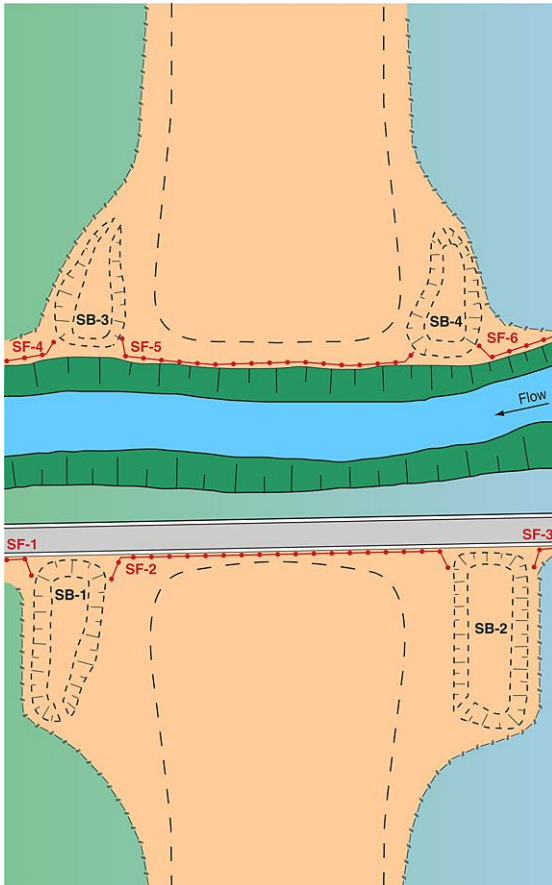
- The number of required sediment traps can be reduced if sediment-laden runoff from both sides of the roadway can be diverted to a single sediment trap located each side of the waterway.

### Sediment basin (Type 1 sediment trap)

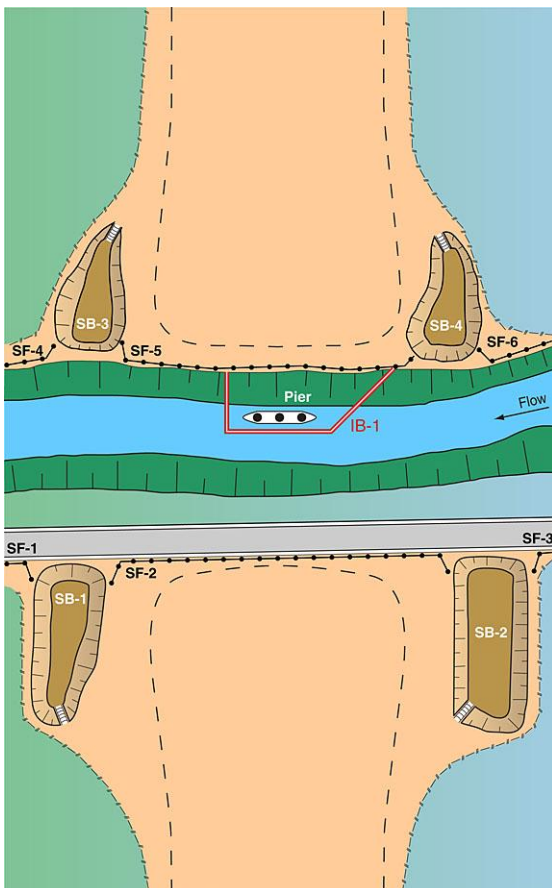


### Alternative layout with dirty water directed under the bridge towards the basins

## Example bridge construction



Stage 1



Stage 2

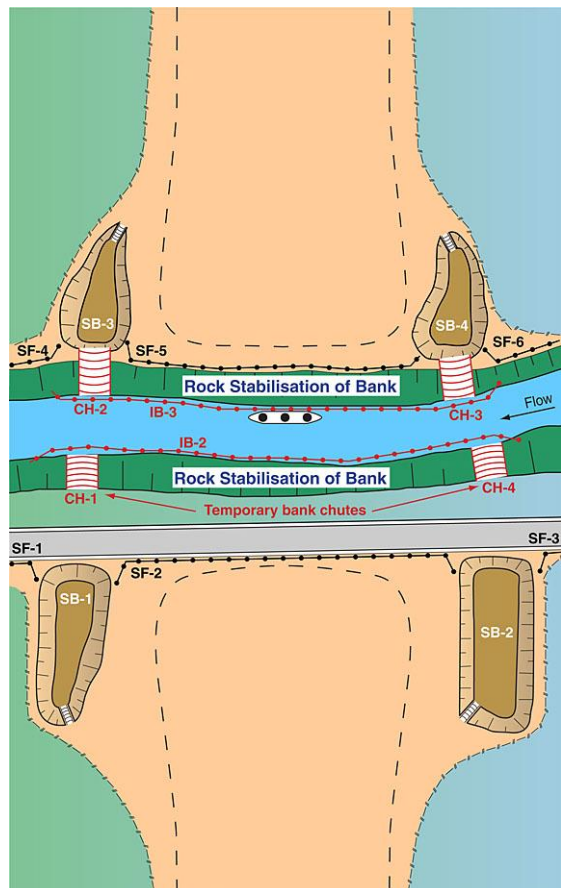


Photo supplied by Catchments & Creeks Pty Ltd

## Bridge construction (NSW)

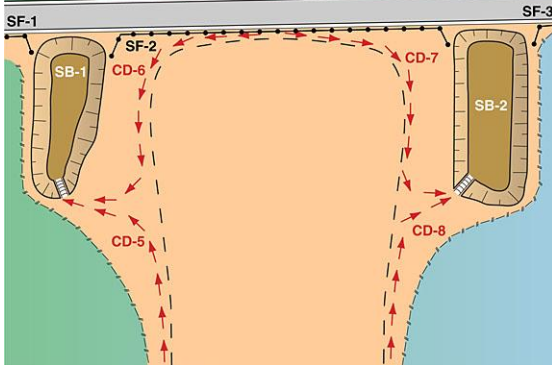
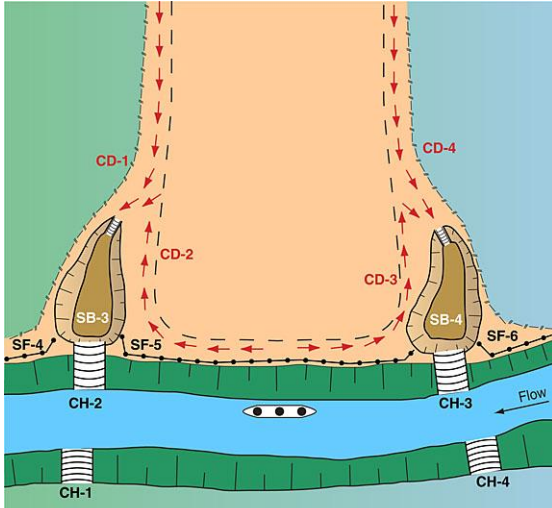
### ESC practices for bridge construction

- Erosion and sediment control practices typically include:
  - marking out non-disturbance areas
  - sediment fence (SF) located along down-slope edge of land clearing (riparian vegetation should not be cleared unnecessarily)
  - construction of sediment basins (SB)
  - isolation barriers (IB) around piers
  - sediment fence isolation barrier or silt curtain installed along the water's edge.

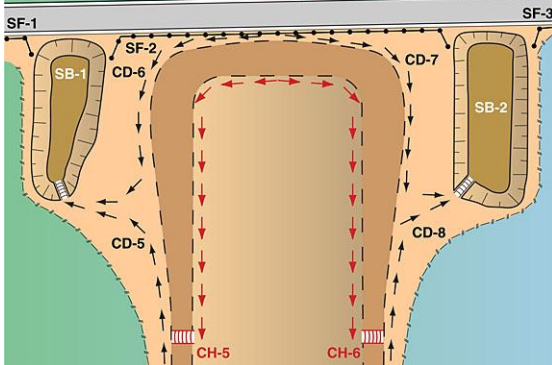
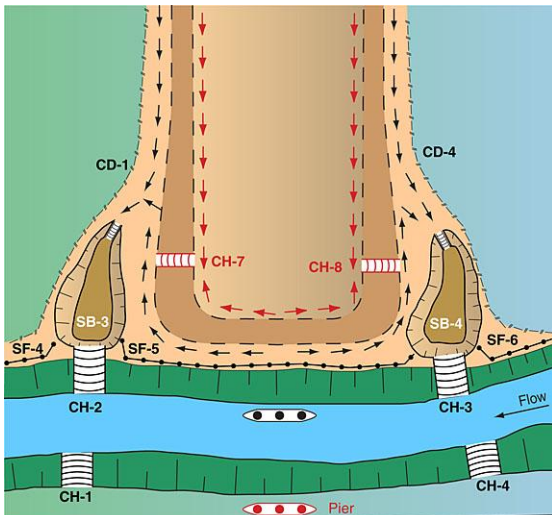


Stage 3

## Example bridge construction



Stage 4



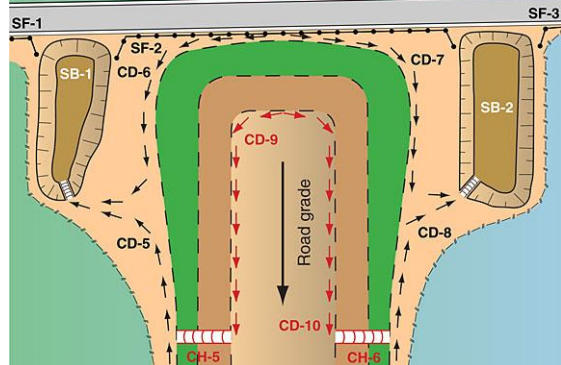
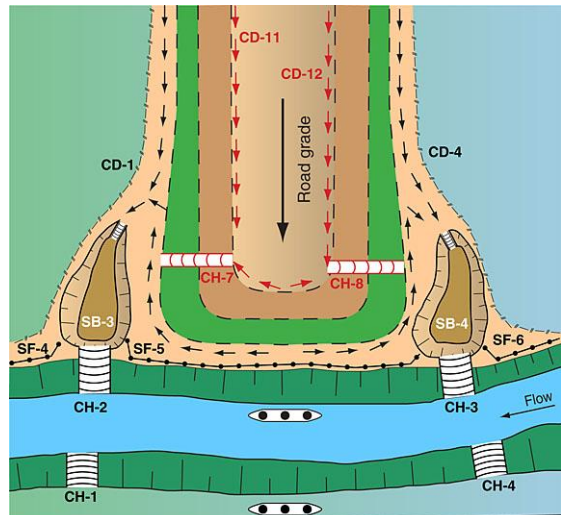
Stage 5



Bridge construction (Qld)

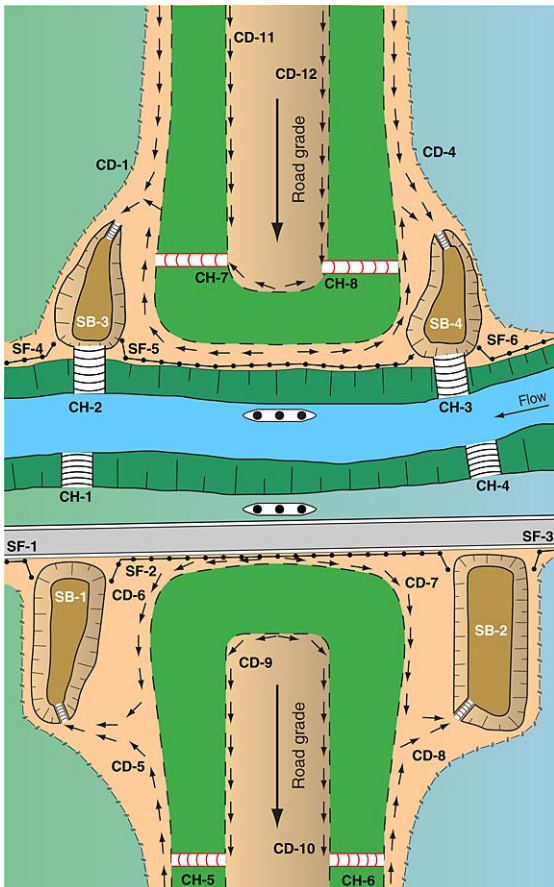
## ESC practices for bridge construction

- Erosion and sediment control practices typically include:
  - temporary catch drains (CD) to direct dirty water to sediment basins
  - earth windrows formed along the edge of embankment works in the event of imminent rainfall
  - temporary filter cloth (or other) batter chutes (CH) to direct embankment runoff down recently formed fill batters.

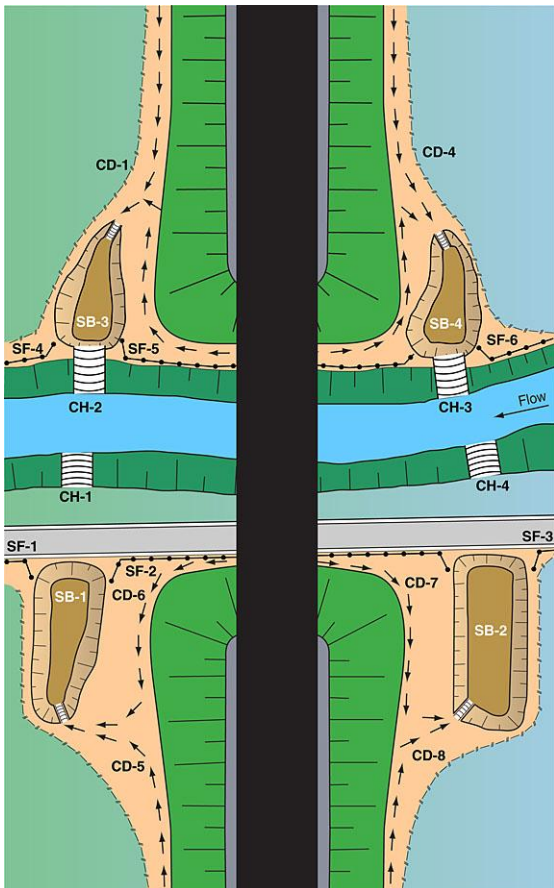


Stage 6

## Example bridge construction



Stage 7



Stage 8

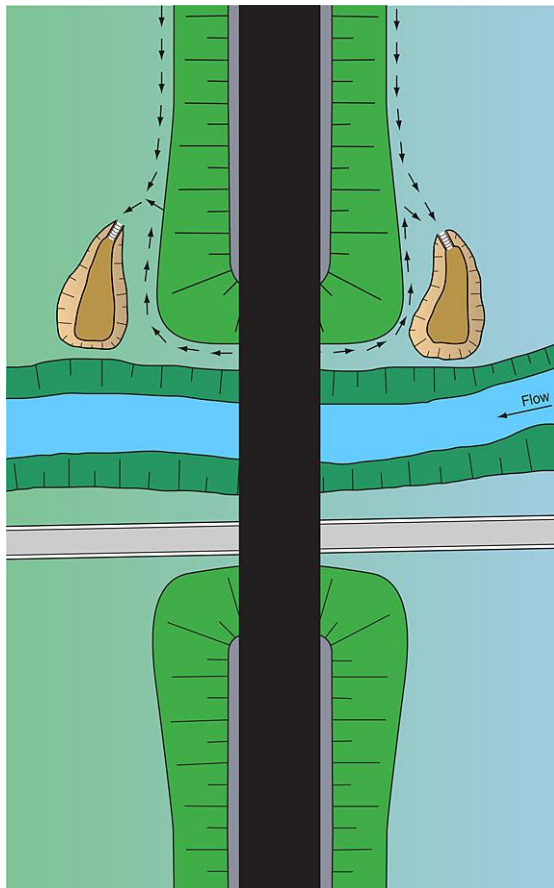


Photo supplied by Catchments & Creeks Pty Ltd

## Bridge construction (NSW)

### ESC practices for bridge construction

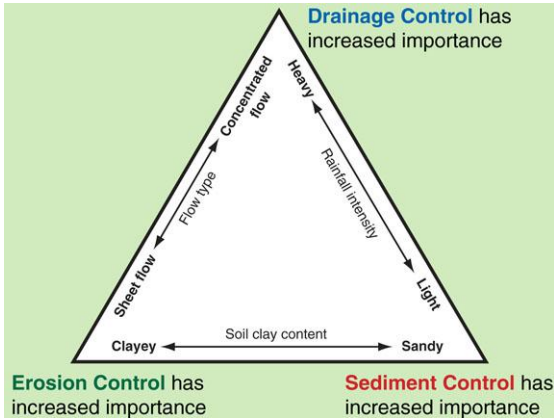
- Erosion and sediment control practices typically include:
  - batter stabilisation measures applied to fill embankments after the embankment exceeds a height of 3 m, and then after each further 3 m rise
  - batter revegetation applied as soon as practical
  - major sediment traps converted into permanent stormwater treatment ponds
  - disturbed areas revegetated.



Final road layout with retained basins

## **5. Instream Work Practices**

## Introduction



### The focus of general ESC activities



### Dry weather ESC measures (NSW)



### Use of a filter tube to treat water (Qld)



### Pumping water to a grass filter bed

### Differences between instream and off-stream erosion and sediment control

- The fundamental principles of construction site erosion and sediment control (ESC) apply to all work sites, including instream work activities.
- However, for instream work activities there are some key differences in how these principles are applied to:
  - off-stream activities
  - instream activities.

### A focus on dry weather conditions

- In general construction, the focus is on managing and treating stormwater runoff during periods of wet weather—the site is generally dry during dry weather.
- However, for instream activities the focus is on managing:
  - stream flows and de-watering activities during dry weather conditions
  - local stormwater runoff (lateral inflows) during wet weather conditions.

### A focus on filtration processes

- In general construction, sediment control measures primarily utilise gravitational settlement to remove sediments from dirty water.
- However, for instream work activities, there is a greater use of filtration processes to clean dirty water, including:
  - passing water through filter tubes, and
  - allowing dirty water to infiltrate soil (e.g. discharging over grassed filter beds).

### Better utilisation of soil infiltration

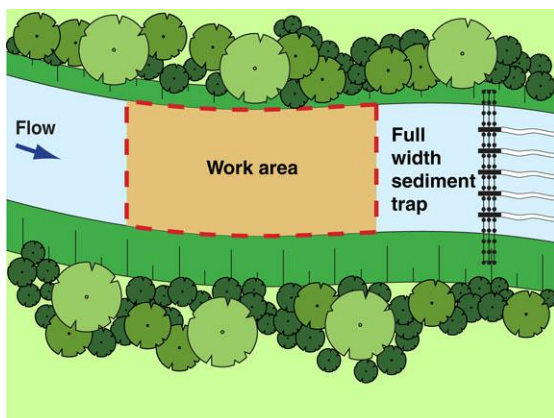
- In general construction, the soil that surrounds a work site is generally saturated at the time sediment control processes are activated (because of the wet weather).
- However, for instream work activities, there is a stronger possibility that the surrounding soil could be 'dry' and able to be used to infiltrate small volumes of site water, thus providing a highly efficient filtration process.

## Consideration of alternative work procedures

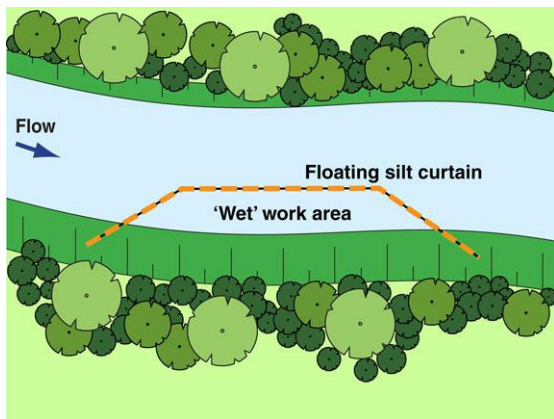


Photo supplied by Catchments & Creeks Pty Ltd

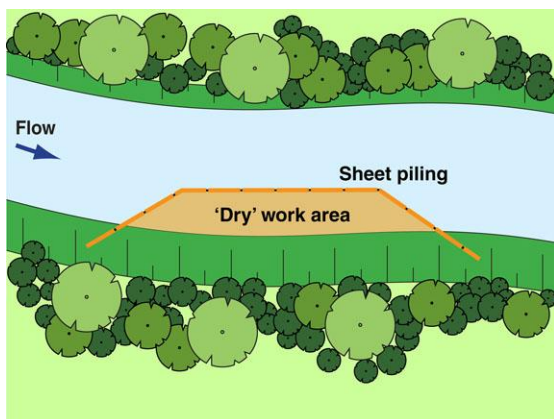
Site de-watering



Full-width bed disturbance



'Wet' work area



'Dry' work area

### Introduction

- There is almost always more than one way of conducting instream work activities.
- Work options are typically based on:
  - is full-width bed disturbance required
  - can the works be isolated from stream flows
  - will it be necessary to create a dry work area
  - will site de-watering be required
  - will sediment de-watering be required.

### Full-width bed disturbance

- If it is necessary to cause soil disturbance across the full width of the channel without staging the disturbance, then:
  - will it be possible to conduct the works during a period of zero flow
  - can stream flows be diverted around the disturbance (e.g. bypass channel or a pumped bypass)
  - in small waterways it may be possible to use a full-width instream sediment trap (usually the least preferred option).

### Isolated work sites

- If only partial bed disturbance is required, or if the works can be staged into isolated areas of disturbance, then:
  - where possible, still try to conduct the works during a period of zero flow.

Otherwise:

- a porous flow diversion barrier could be used to isolate a 'wet' work area, or
- an impervious flow diversion barrier may be needed to form a 'dry' work area.

### Dry work sites

- If it will be necessary to establish a dry work area, then:
  - where possible, try to conduct the works during a period of zero flow.

Otherwise:

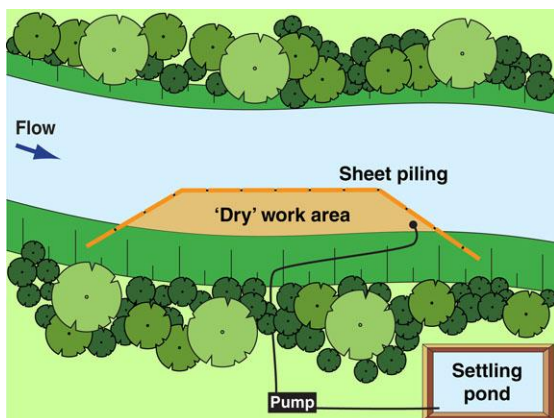
- use an isolation barrier to isolate the work area from the stream flow, and
- use pumps to de-water the area and direct such water to an off-stream sediment control system.

## Consideration of alternative work procedures

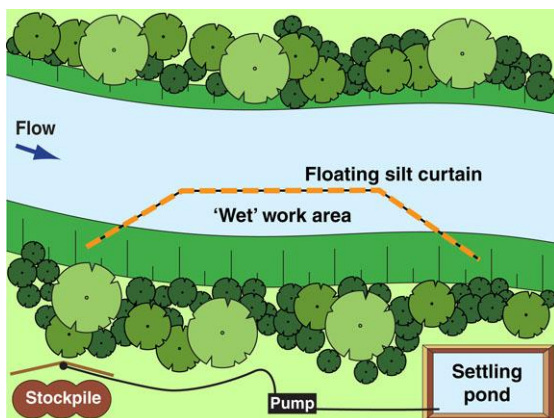


Photo supplied by Catchments & Creeks Pty Ltd

**Construction of a culvert base slab (Qld)**



**Site de-watering**



**Stockpile de-watering**



Photo supplied by Catchments & Creeks Pty Ltd

**De-watering filter pond (Qld)**

### Culvert construction

- The construction of waterway culverts usually requires full-width bed disturbance in order to construct the base slab.
- Even though it is technically possible to construct such base slabs in stages, such work practices are likely to be resisted because:
  - this will require a redesign of the slab reinforcing, and
  - increased construction costs.

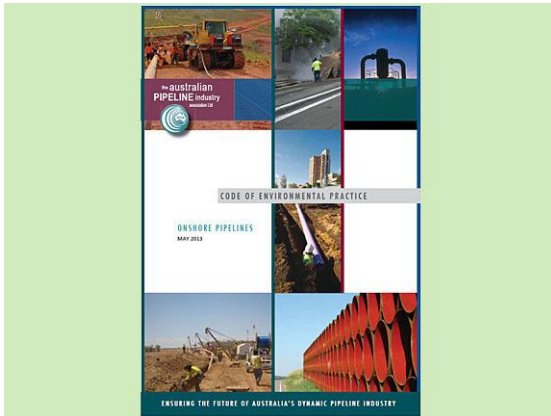
### Site de-watering

- If site de-watering is going to be required, then the treatment options include:
  - pumping the water to a point where it can be released as sheet flow over a well grassed area
  - pumping the water to a temporary irrigation system that can spread the water over a large vegetated area
  - pumping the water to an off-stream sediment control system, such as a settling pond.

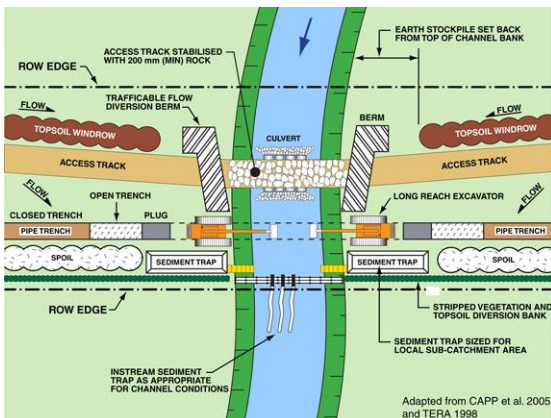
### Sediment de-watering

- Material removed from the waterbody usually needs to be de-watered before being transported off the site.
- Treatment options include:
  - initially stockpile the material within the isolation area so it can drain excess water (which is then treated with the rest of the site de-watering)
  - stockpile the material at a suitable off-stream location well away from the waterbody so that the draining water can infiltrate into the soil
  - stockpile the material in an off-stream location where the draining water can be collected within a sump pit, then pumped to a filtration system
  - stockpile the material in an off-stream location where the draining water passes through a Type 2 sediment control system before re-entering the waterbody
  - place the material directly into a truck that then moves to a suitable location away from the waterbody where it allows the material to slowly de-water through the trucks rear gate.

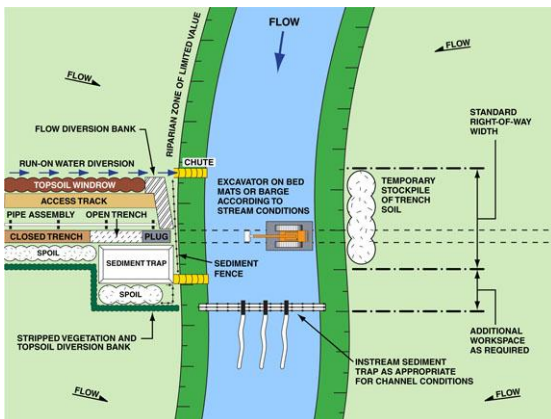
## Pipe crossings of waterways



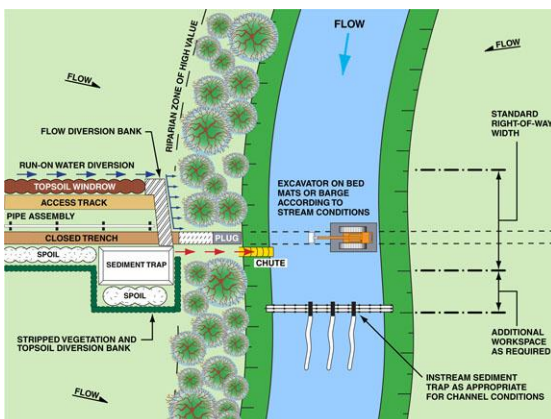
### APIA Code of Environmental Practice



### Minor waterway



### Shallow-bed waterway



### Protection of a riparian zone

## Pipeline crossings

- An expanded discussion on the construction of pipeline crossings can be found in:
  - Erosion and Sediment Control Field Guide for Pipeline Projects – Part 2, Catchments and Creeks (2017)
  - Code of Environmental Practice – Onshore Pipelines, Australian Pipeline Industry Association Ltd (2013)
  - Pipeline Associated Watercourse Crossings, Canada (2005)

## Open cut across a small waterway

- This construction method may be suitable for drainage lines, dry-bed waterways, and non-flowing shallow (typically, < 1 m) water bodies.
- Suitable for alluvial (sand or gravel-based) waterways where the excavator can reach well below that part of the substrate that is likely to migrate during severe floods.
- May not be suitable if the waterway bed contains large boulders or shallow bedrock.

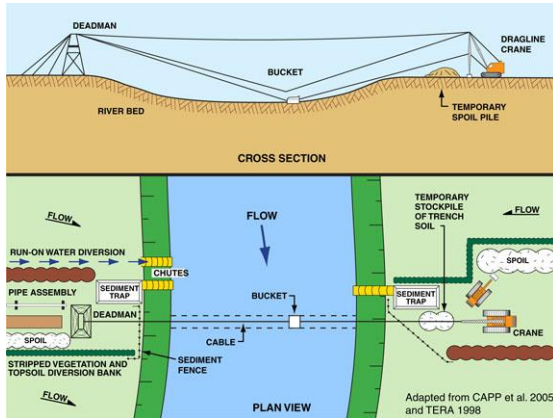
## Open cut across a large ephemeral waterway

- Suitable for the crossing of large dry-bed waterways, and non-flowing shallow (typically, < 1 m) water bodies.
- Suitable for alluvial (sand or gravel-based) waterways where the excavator can reach well below that part of the substrate that is likely to migrate during severe floods.
- May not be suitable if the waterway bed contains large boulders or shallow bedrock.

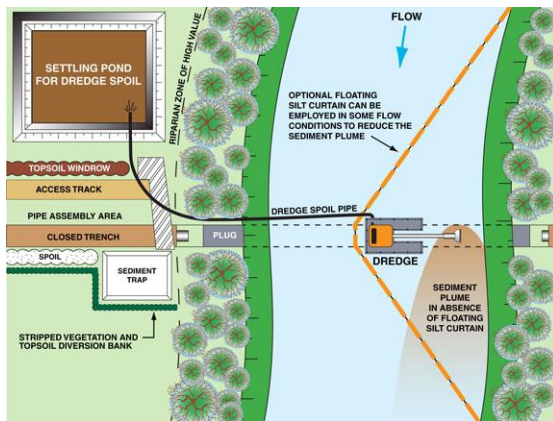
## Open cut across a waterway with existing riparian vegetation

- Riparian vegetation plays an important role in the function of natural waterways, including bank stability, terrestrial habitat, and fish passage during flood events.
- Construction practices should aim to minimise overall disturbance to the riparian zone.
- The critical width of the riparian zone varies from waterway to waterway—refer to local guidelines.

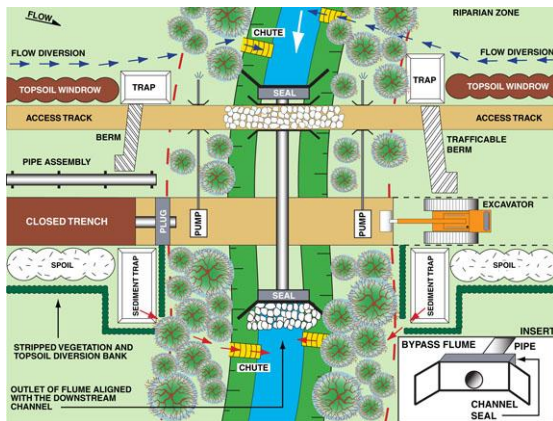
## Pipe crossings of waterways



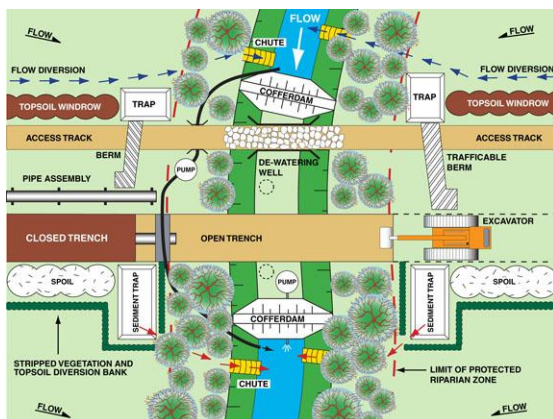
**Dragline pipe trenching**



**Dredge**



**Cofferdams with gravity bypass**



**Cofferdams with pumped bypass**

### Dragline

- This construction technique may be suitable for wide and deep waterways with soft substrate and limited navigational traffic.
- Not suitable if the waterway bed contains large boulders or shallow bedrock.

### Dredging

- This approach may be suitable for wide and deep waterways with soft substrate.
- Not suitable if the waterway bed contains large boulders or shallow bedrock.

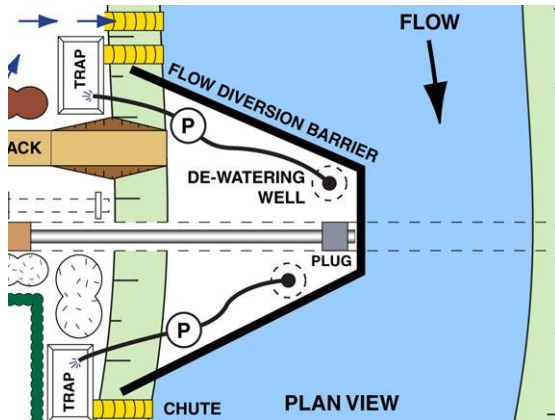
### Cofferdams with gravity bypass

- Suitable for minor, narrow waterways with minimal base flows, and during those periods when flood flows are unlikely to occur, and fish passage is not critical.
- The bypass pipe may be augmented with a pumped bypass.

### Cofferdams with pumped bypass

- Suitable for waterways with minimal base flows, and during those periods when flood flows are unlikely to occur, and fish passage is not critical.

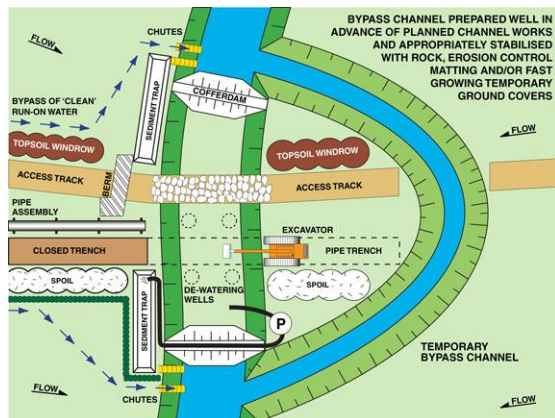
## Pipe crossings of waterways



Two-stage open cut installation

### Two-stage open cut crossing of a waterway

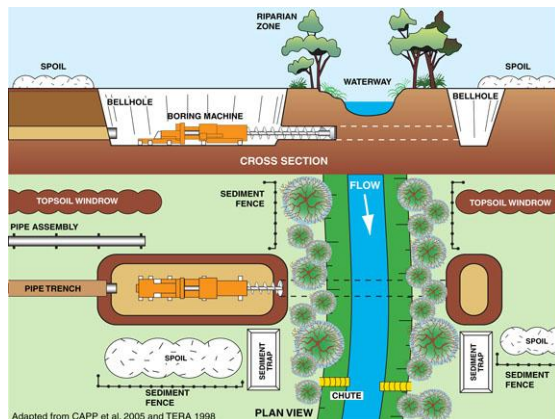
- Applicable to the larger waterways, and waterways where maintaining fish passage is critical.
- May be difficult to apply to some gravel-based (alluvial) waterways due to the difficulty of anchoring/punching the barrier into the gravel bed, and creating a watertight seal.
- Flow diversion or isolation barriers may be constructed using either floating or land-based machinery.



Temporary bypass channel

### Constructed bypass channel

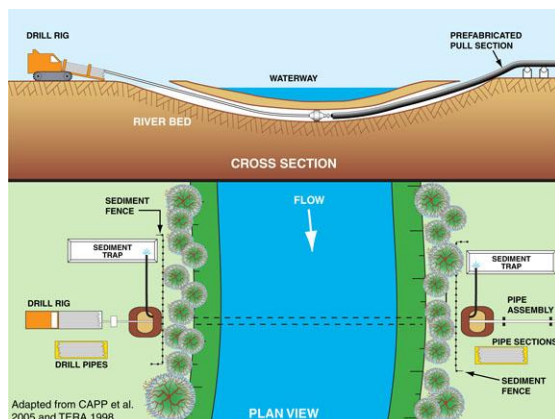
- Extreme care must be taken if the bypass channel is to be constructed through unconsolidated sandy soil because ongoing channel erosion can occur, even after the bypass channel is backfilled and rehabilitated.
- The bypass channel may need to be lined with erosion control mats, or similar, depending of the expected flow velocity.



Horizontal boring

### Horizontal bore and punch, or pipe jacking

- Best suited to passing pipelines under narrow, sensitive waterways containing impermeable substrates.
- The process is not suited to all waterway substrates due to excessive borehole slumping and water seepage.
- Borehole length possibly limited to around 100 m (boring) or 50 m (pipe jacking).



Horizontal directional drilling

### Horizontal directional drilling

- Best suited to passing pipelines under sensitive waterways.
- The maximum approach angle of the pilot hole is around 10–20 degrees.
- Success depends on the type and consistency of the substrate (bed material).

## Erosion and Sediment Control Plans



Photo supplied by Catchments & Creeks Pty Ltd

**De-silting a storm drain outlet (Qld)**

### Minor instream works

- The level of detail supplied in the *Erosion and Sediment Control Plan* (ESCP) must be commensurate with the complexity of the proposal and the assessed environmental risk.
- On low-risk sites, such as routine council maintenance projects:
  - the plans may be simple sketches, such as shown below
  - alternatively, councils may choose to develop generic plans for those tasks that are repeated annually.

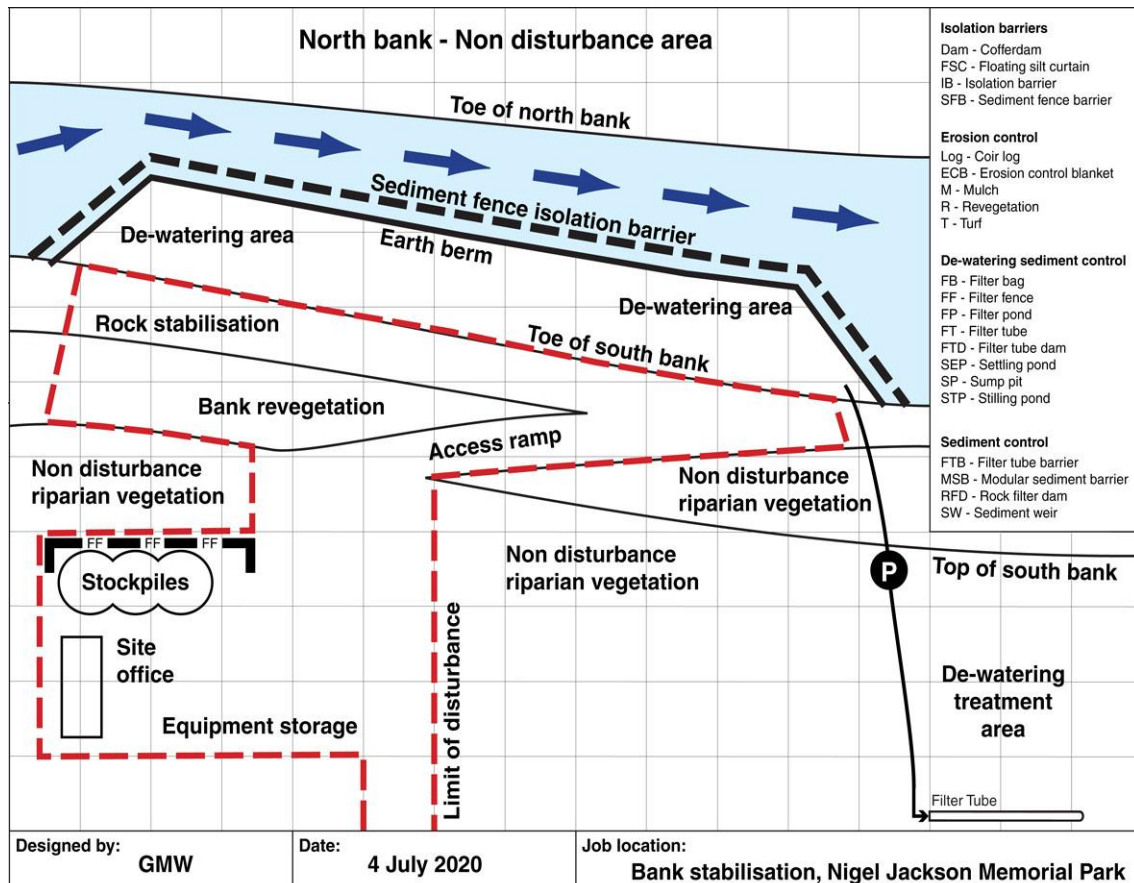


Photo supplied by Catchments & Creeks Pty Ltd

**Creek bank stabilisation (Qld)**

### Major instream construction projects

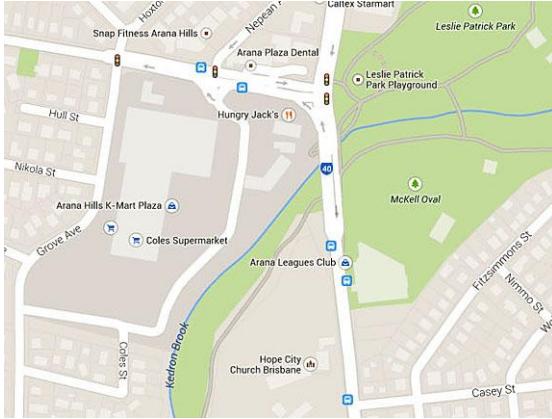
- For major construction projects, the ESCP may need to consist of several plans, including:
  - limits of site disturbance
  - temporary ESC measures applied during site establishment
  - the primary ESC plans
  - site rehabilitation plans.
- Specialist advice may be required from a waterway ecologist if major channel disturbance is required.



**Example Erosion and Sediment Control Plan for a bank stabilisation project**



## Case Study – Creek bank stabilisation, Grovely, Qld



Location map

### Background

- This project involved the rebuilding of a creek bank that had been severely eroded during the flood events in 2009, 2010 and 2011.
- The eroded bank presented a safety risk to the adjacent park and school, plus a source of sediment for the creek.
- The site is located immediately upstream of the Dawson Parade bridge over Kedron Brook in the suburb of Grovely, Brisbane.
- The works were conducted in late 2012.



Photo supplied by Catchments & Creeks Pty Ltd

Site conditions in 2010



Photo supplied by Catchments & Creeks Pty Ltd

Erosion visible on the left bank, 2012



Photo supplied by Catchments & Creeks Pty Ltd

Site office and stockpile area

### Site office

- A site office, equipment storage area and stockpile area was established in the park adjacent to the creek.
- The site office was surrounded with temporary fencing.
- It is noted that the author did not play a role in the design or operation of this project.



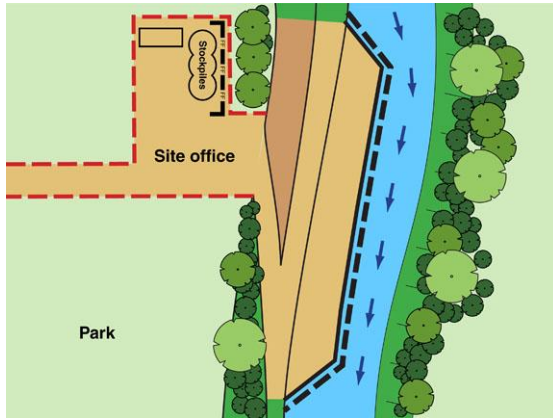
Photo supplied by Catchments & Creeks Pty Ltd

Stockpile area

### Stockpile area

- A sediment fence was installed between the creek and the stockpiles.

## Case Study – Creek bank stabilisation, Grovely



Approximate layout of work site



Photo supplied by Catchments & Creeks Pty Ltd

Isolation of the work area



Photo supplied by Catchments & Creeks Pty Ltd

Flow diversion berm



Photo supplied by Catchments & Creeks Pty Ltd

Rock filter dam

### Erosion and Sediment Control Plan

- This sketch demonstrates the general layout of the site and the proposed erosion and sediment control measures.

### Bypass of the creek flow

- Vegetation was cleared from the bank and a vehicle access ramp was formed down the bank.
- An earth berm was formed on the creek bed to divert the low-flow channel to the northern side of the creek.
- Filter cloth (white) was placed over the upstream end of the earth berm.
- The isolated section of creek bed was de-watered to allow equipment to access the base of the eroded creek bank.

### Flow diversion berm

- The flow diversion berm was formed from earth obtained from the formation of the vehicle access ramp.

### Instream sediment trap

- A minor rock filter dam was installed across the low-flow bypass channel at the downstream end of the work area to control sediment during the formation of the flow diversion berm.
- The rock filter dam remained in place until construction vehicles finally left the channel and the vehicle access ramp was removed and replaced with rock.

## Case Study – Creek bank stabilisation, Grovely



**Reconstruction of the eroded bank**



**Sediment fence isolation barrier**



**Upstream rock stabilisation**



**Removal of rock filter dam**

### Earthworks

- Earth is imported to reconstruct the eroded creek bank.
- Sediment-laden water generated by the movement of vehicles is isolated from the creek flow by the earth berm.

### Sediment fence isolation barrier

- A sediment fence isolation barrier was installed above the earth berm to provide additional flow protection to the work area.
- An alternative would have been to first construct a sediment fence isolation barrier in the live stream, then construct an earth berm behind the sediment fence.
- However, the ability to successfully construct a sediment fence isolation barrier in a creek depends on how much bed rock exists in the creek.

### Placement of rock

- Rock stabilisation is placed over the newly formed creek bank.
- Earth fill (topsoil) is introduced to the rock during its placement in order to fill all voids prior to pocket planting.
- Ideally, filter cloth should not have been placed under the rocks as this cloth can interfere with the root growth of the established bank vegetation.
- The isolation barrier is removed from the creek bed.

### Removal of materials from creek bed

- All materials are removed from the creek bed.

## Case Study – Creek bank stabilisation, Grovely



**Downstream rock stabilisation**

### Rock placement

- The vehicle access ramp is removed and the creek bank is reshaped prior to placement of the rock stabilisation on the downstream section of creek bank.



**Site revegetation**

### Site revegetation

- All voids in the rock work are filled with soil (preferable topsoil).
- The creek bank is covered with jute mesh.
- Bank revegetation is established within the rock work and overbank area.
- The overbank area is also covered with jute mesh.



**Turfing of overbank disturbance**

### Rehabilitation of site office area

- The site office, equipment storage area and stockpile area are turfed.
- All vehicle-compacted soil must be ripped before placement of the turf in order to allow the turf roots to freely establish within the underlying soil.



**Post-construction, 2014**

### Post-construction

- Shortly after the works were completed the site experienced a significant stream flow which disturbed much of the jute mesh.
- Some bank vegetation was lost during this storm event.

## **6. Erosion and Sediment Control Plan Checklist**

# Erosion & Sediment Control Plan Checklist

LOCATION OF DEVELOPMENT .....

.....

REVIEWER ..... DATE .....

SIGNATURE .....

N/A – not applicable

– acceptable controls adopted

– measures are not acceptable, or a potential problem exists

## Part A: Initial plan review

Item	Consideration	Assessment
1	<i>Erosion Hazard Assessment Form</i> completed for the site.	
2	<i>Supporting Documentation</i> supplied with the ESCP.	
3	Copy of calculation sheets supplied.	
4	ESC specifications and construction drawings supplied.	
5	Inspection and Test Plan (ITP) supplied	
6	Legend provided to identify all ESC measures on the plans.	
7	ESC <i>Installation Sequence</i> supplied.	
8	<i>Installation Sequence</i> is appropriate for the site conditions.	
9	<i>Installation Sequence</i> clearly indicates which sediment control measures must be installed prior to land disturbance.	
10	Soil test results (including soil erodibility) supplied.	
11	Extent of land disturbance (including cut and fill areas) shown.	
12	Adequate identification/protection of non-disturbance areas.	
13	Protected trees and buffer zones identified.	
14	Appropriate staging of land clearing.	
15	On-site watercourses and riparian zones protected.	
16	Existing and/or final contours shown (as required).	
17	Location of all ESC measures clearly shown.	
18	All ESC measures located within the property.	
19	Plans signed by appropriate professional(s).	

## Part B: Site assessment

Item	Consideration	Assessment
20	On-site water “values” and discharge standards (water quality objectives) identified.	
21	Soil Map provided.	
22	Location of potential dispersive soils identified.	
23	Location of potential acid sulfate soils identified.	
24	Potential landslip/mass movement areas identified.	
25	High and extreme erosion risk areas identified and protected.	
26	Soils of extreme pH identified and amelioration specified.	

## Part C: Site establishment

Item	Consideration	Assessment
27	Site access points limited to the minimum necessary, clearly identified on plans, and appropriate controls specified.	
28	Drainage controls indicated on the entry/exit pad (if necessary).	
29	Site office and car parking areas identified and provided with adequate drainage, erosion and sediment controls.	
30	Technical notes included on best practice site management including dust, chemical, oil, fuel, litter and debris control.	
31	Stockpile locations clearly identified and located away from protected vegetation and overland flow paths.	
32	Stockpiles located at least 5 m away from top of watercourse banks.	
33	Adequate up-slope drainage controls (if necessary) and down-slope sediment controls placed adjacent to stockpiles.	
34	Temporary access roads/tracks identified, with appropriate drainage/erosion controls specified.	
35	<i>Temporary Watercourse Crossings</i> identified and protected.	
36	<i>Temporary Watercourse Crossings</i> are appropriate for fish passage requirements.	
37	Minimum non-disturbance zone between unsealed access tracks and the edge of streams is at least the width of the stream (measured at the top of the bank) or 30 m whichever is the lesser.	

## Part D: Drainage controls

Item	Consideration	Assessment
38	Construction Drainage Plans prepared for each major stage of earthworks.	
39	All temporary construction roads and access tracks shown on the Construction Drainage Plans.	
40	Temporary drainage controls designed to the appropriate standard and hydraulic analysis provided.	
41	Hydraulic analysis indicates appropriate flow velocities.	
42	Hydraulic analysis indicates appropriate flow capacity.	
43	Flow from "clean" external catchments diverted around/through site in a non-erosive manner.	
44	Internal "dirty" water drainage lines identified and directed to sediment controls.	
45	Appropriate drainage controls located immediately up-slope of neighbouring, down-slope residential areas.	
46	All site drainage inflow and outflow points identified.	
47	All water discharges from the site at legal points of discharge.	
48	All water discharges through stabilised outlets onto stable land.	
49	Maximum spacing of drains on long, open soil slopes is appropriate for the gradient and soil type.	
50	Appropriate flow velocity controls (e.g. <i>Check Dams</i> ) or scour controls (e.g. turf or <i>Erosion Control Mats</i> ) specified.	
51	<i>Catch Drains</i> or <i>Flow Diversion Banks</i> located at top of cut and fill batters.	
52	Temporary <i>Catch Drains</i> <u>not</u> indicated on dispersive soils.	
53	Rock <i>Check Dams</i> <u>not</u> specified in shallow (i.e. < 500 mm deep) drains.	
54	Water flow is appropriately conveyed down constructed earth slopes (e.g. through <i>Slope Drains</i> or <i>Chutes</i> ).	
55	All <i>Slope Drains</i> and <i>Chutes</i> have stabilised inlets and outlets.	
56	Appropriate drainage controls on unsealed roads and access tracks.	
57	Technical notes require all runoff from newly constructed rooves to be immediately connected to drainage system.	
58	Overland flow appropriately controlled around <i>Temporary Watercourse Crossings</i> .	

## Part E: Erosion control

Item	Consideration	Assessment
59	The erosion control standard is consistent with the rainfall erosivity, environmental risk, and clay content of exposed soil.	
60	The erosion control standard is consistent with the requirements of regulatory authority.	
61	Application rates specified for mulching.	
62	Specified mulch stabilisation measures are appropriate for the soil slope (gradient).	
63	Appropriate drainage controls installed to minimise mulch being washed off the slope/site.	
64	Synthetic (plastic) mesh reinforced <i>Erosion Control Blankets</i> <u>not</u> specified in or adjacent to susceptible wildlife habitats.	
65	Emergency short-term erosion control measures specified (e.g. in event of construction delays, pre-storm activities).	
66	Technical notes indicate what additional works are required if construction occurs during the wet season.	
67	Dust control measures specified.	
68	Disturbed soil with an Exchangeable Sodium Percentage (ESP) greater than 6% is to be treated to control soil dispersion.	

## Part F: Site stabilisation/revegetation

Item	Consideration	Assessment
69	Vegetation Management Plan and/or Landscape Plan provided.	
70	Site stabilisation/rehabilitation plan provided.	
71	Minimum soil protective cover of 70% specified on ESCP or in the Supporting Documentation.	
72	Appropriate soil preparation measures specified prior to revegetation.	
73	Timing and specification for any temporary vegetation is provided.	
74	Application of permanent site revegetation is appropriately staged.	
75	Minimum specifications for imported topsoil supplied.	
76	Specifications and application rates for soil adjustments provided (soil report).	
77	Specifications and application rates for seeding, mulches and hydraulically applied soil covers provided.	

## Part G: Supplementary sediment controls

Item	Consideration	Assessment
78	Every appropriate opportunity has been taken to trap sediment as close to the initial source of erosion as is practicable <u>without</u> placing sediment controls in locations where they could cause hydraulic, erosion, or safety issues.	
79	Sediment traps placed on public roadways will <u>not</u> cause safety issues.	
80	No sub-catchment relies solely on supplementary sediment control measures.	
81	<i>Straw Bales</i> are <u>not</u> specified for sediment control, unless justified by <u>exceptional</u> circumstances (e.g. as a short-term control during the installation of the primary sediment trap).	
82	The ESCP provides sufficient information to control the installation and use of supplementary sediment traps.	

## Part H: Sediment control sheet flow

Item	Consideration	Assessment
83	No sediment-laden water leaves the site untreated.	
84	"Sheet flow" control measures (e.g. <i>Buffer Zones, Grassed Filter Strips, and Sediment Fence</i> ) <u>not</u> specified in areas of concentrated flow.	
85	<i>Grass Filter Strips</i> will not cause water to be diverted along the up-slope edge of the filter strip.	
86	The width of sediment control <i>Buffer Zones</i> is appropriate for the land slope (gradient).	
87	Geotextile <i>Filter Fences</i> are only used to control sediment runoff from earth stockpiles.	
88	<p><i>Sediment Fences:</i></p> <p>(a) Located and detailed (i.e. with regular 'returns') such that runoff will pond uniformly, or at regular intervals, along the fence.</p> <p>(b) Ends of each fence turned up the slope to control flow bypass.</p> <p>(c) Each fence clearly identified as either 'woven' or 'non-woven' as appropriate, otherwise a summary table is provided identifying the fabric specification for each fence.</p> <p>(d) Specifications show a maximum 2 m spacing of support post.</p> <p>(e) The fence is located at least 2 m from base of fill slopes.</p> <p>(f) Specifications (design details) show adequate trenching of fabric.</p>	<p>.....</p> <p>.....</p> <p>.....</p> <p>.....</p> <p>.....</p> <p>.....</p>

## Part I: Sediment control concentrated flow

Item	Consideration	Assessment
89	Appropriate sediment control standard specified (i.e. Type 1, Type 2, or Type 3)	
90	Location of all sediment control measures clearly shown.	
91	The location and operation of sediment control measures will <u>not</u> cause safety issues or flooding of adjacent properties.	
92	Straw bale check dams <u>not</u> specified for sediment control.	
93	Appropriate sediment control measures are specified for all "sag" and "on-grade" kerb inlets.	
94	Appropriate sediment control measures specified for all field (drop) inlets.	
95	Appropriate sediment control measures specified for all culverts and pipe inlets.	
96	Where specified on stormwater outlets, end-of-pipe sediment traps are located well downstream (e.g. 10 x pipe dia.) of outlet.	
97	Type 2 sediment traps (e.g. <i>Rock Filter Dams, Sediment Trenches, Sediment Weirs</i> ):  (a) Have adequate up-slope pond area.  (b) Have an appropriately sized sediment collection pit.  (c) Designed for an appropriate storm frequency.	..... ..... .....
98	Appropriate access is provided to all sediment traps for maintenance and sediment removal.	
99	Appropriate sediment control measures are specified for de-watering operations specified (technical notes).	
100	Sediment controls are placed within streams ONLY as a last resort, and only with written approval from all appropriate Regulatory Authorities.	
101	Sediment controls placed in and around drainage channels are appropriate for the expected flow conditions.	

## Part J: Sediment Basins

Item	Consideration	Assessment
102	The location and operation of <i>Sediment Basins</i> will not cause safety issues or flooding of adjacent properties.	
103	Type of each <i>Sediment Basin</i> is appropriate for the soil conditions.	
104	Soil testing and all design calculations provided for all <i>Sediment Basins</i> .	
105	Appropriate construction specifications provided for all basin embankments.	
106	Actual size (including all dimensions) of each <i>Sediment Basin</i> , including spillway, is shown on the plans.	
107	Sediment-laden water is able to flow to the required basin during all stages of earthworks and soil disturbance.	
108	All <i>Sediment Basins</i> have: (a) Stable inflow conditions. (b) Inlet baffle (if required). (c) Minimum 3:1 length to width, otherwise baffles installed. (d) Suitable access for de-silting and maintenance. (e) Stabilised emergency spillway and energy dissipater. (f) Stabilised batters/embankments. (g) Safety or exclusion fencing (as required). (h) Operating conditions and water quality standards specified.	..... ..... ..... ..... ..... ..... .....
109	Riser pipe outlet systems for “dry” basins: (a) Debris/anti-vortex inlet screen specified. (b) Anti-flotation weight specified. (c) Details for riser pipe filtration system specified. (d) Anti-seepage collars specified.	..... ..... ..... .....
110	Appropriate monitoring and maintenance requirements for all <i>Sediment Basins</i> provided.	
111	Basin sizing, hydraulic design (spillway) and embankment specification certified by appropriate professionals. (a) Review of spillway hydraulics. (b) Geotechnical review of embankment construction & stability. (c) ESC specialist review of basin selection and design.	..... ..... .....

## Part K: Instream works

Item	Consideration	Assessment
112	All necessary site data (soil and flow conditions, stream type, site access conditions).	
113	All necessary State and local government approvals have been obtained.	
114	<i>Temporary Watercourse Crossings</i> (e.g. construction access) have been reduced to the minimum practical number.	
115	Instream disturbance is limited to the minimum necessary to complete the proposed works.	
116	Instream disturbances have been appropriately staged to minimise exposure to storm runoff and stream flows.	
117	Instream works have been programmed for that time of the year that will minimise overall potential environmental harm: (a) avoiding seasonal high flows; (b) avoiding periods of likely fish migration; (c) avoiding active bird migration periods (RAMSAR wetlands).	..... ..... .....
118	Instream structures are not located on, or adjacent to, unstable or highly mobile channel bends.	
119	Construction works will not unnecessarily disturb instream or riparian vegetation.	
120	Wherever reasonable and practicable, overbank disturbances will be limited to only one bank.	
121	Stormwater runoff moving towards the channel from adjacent areas will be appropriately diverted around soil disturbances.	
122	Where stormwater cannot be diverted around soil disturbances, stabilised bank <i>Chute</i> (s) have been provided to carry stormwater down the channel banks in a non-erosive manner.	
123	Wherever reasonable and practicable, dry-weather channel flows are diverted around in-bank disturbances: (a) dry channel conditions expected; (b) flow diversion using cofferdams and bypass pipes; (c) flow diversion using instream <i>Isolation Barriers</i> .	..... ..... .....
124	Appropriate temporary erosion control measures (if necessary) have been proposed.	
125	Synthetic reinforced erosion control blankets/mats have <u>not</u> been specified where there is a potential threat to wildlife.	
126	All reasonable and practicable measures have been taken to avoid the need for instream sediment control measures within flowing streams.	
127	Proposed instream sediment control measures are appropriate for the expected site access and stream flow conditions.	
128	Appropriate material de-watering procedures and process areas have been identified.	
129	Appropriate bed, bank and overbank rehabilitation measures have been proposed.	

## Part L: Site monitoring and maintenance

Item	Consideration	Assessment
130	Site inspection program supplied.	
131	Monitoring and Maintenance Program provided for all drainage, erosion and sediment controls.	
132	Water quality monitoring program supplied, including construction phase Water Quality Objectives (WQOs).	
133	Water quality monitoring locations/stations identified.	
134	Appropriate safety issues addressed for site monitoring and data (e.g. water sample) collection.	
135	Adequate ESC maintenance requirements have been specified either on the ESCP or within the Supporting Documentation.	

## 7. Glossary of terms

<b>AHD</b>	Australian Height Datum. A common datum used in land survey.
<b>Clay</b>	Soil particles less than 0.002 mm in equivalent diameter. When used as a soil texture group such soil contains at least 35% clay and no more than 40% silt.
<b>Clayey soil</b>	A soil that contains at least 20% clay. These are fine-grained soils that readily form a clod when compressed in the hand, feel very smooth and sticky when wet, and are very difficult to shovel or break-up when compacted.
<b>Clay loam</b>	A soil texture group representing a well-graded soil composed of approximately equal parts by weight of clay, silt and sand [when dispersed].
<b>Clean water</b>	Water that either enters the property from an external source and has not been further contaminated by sediment within the property; or water that has originated from the site and is of such quality that it either does not need to be treated in order to achieve the required water quality standard, or would not be further improved if it was to pass through the type of sediment trap specified for the sub-catchment.
<b>Construction phase</b>	<p>That period of civil works extending from initial site access (excluding preliminary site survey and data collection) to the commencement of the contracted/specified maintenance period. On staged works, the construction phase extends to the commencement of the maintenance period of the final stage of completed works.</p> <p>A regulatory authority may specify on a site-by-site basis that the construction phase includes the maintenance period.</p>
<b>Construction site</b>	A site where major earthworks, civil construction (e.g. construction of public works and infrastructure) and/or non-domestic building works are conducted.
<b>Dirty water</b>	Water not classified as clean water.
<b>Dispersible soil</b>	<p>A structurally unstable soil that readily disperses into its constituent particles (clay, silt and sand) when placed in water. Moderately to highly dispersible soils are normally highly erodible and are likely to be susceptible to tunnel erosion.</p> <p>Most sodic soils are dispersible, but not all dispersible soils may be classified as sodic.</p> <p>Some dispersible soils are resistant to erosion unless mechanically disturbed.</p>
<b>Dispersive soil</b>	Terminology commonly used in engineering. See 'dispersible soil'.
<b>Drainage control measure</b>	<p>Any system, procedure or material employed to:</p> <ul style="list-style-type: none"><li>• prevent or minimise soil erosion caused by 'concentrated' overland flow (including the management of rill and gully erosion);</li><li>• divert flow around or through a work site or soil disturbance; or divert 'clean' water away from a sediment trap;</li><li>• to appropriately manage the movement of 'clean' and 'dirty' water through a work site.</li></ul>
<b>Drop inlet</b>	An inlet to a sub-surface drainage system located within an open area where the water falls vertically into the connecting chamber. Known also as a 'field inlet'.
<b>Dry seeding</b>	The application of grass seed without water.

<b>Environmental harm</b>	Any adverse effect, or potential adverse effect (whether temporary or permanent) on an environmental value.
<b>Environmental risk</b>	The potential of an activity to cause harm, whether material, serious, reversible or irreversible, to an environmental value. It includes potential nuisance caused to a property or person.
<b>Erosion and Sediment Control Plan (ESCP)</b>	A site plan, or set of plans, including diagrams and explanatory notes, that demonstrate proposed measures to control stormwater drainage, soil erosion, and sediment runoff during the construction/building, site stabilisation, and maintenance phases of a construction, building or other soil disturbance activity.
<b>Erosion control measure</b>	<p>A system, procedure or material used to prevent or reduce the effects of erosion on soil and other granular material.</p> <p>Within this document, <i>erosion control measures</i> primarily refer to those measures that can aid in the control of raindrop impact and sheet erosion.</p>
<b>ESC</b>	Erosion and sediment control.
<b>ESCP</b>	Erosion and Sediment Control Plan.
<b>Field inlet</b>	An inlet to a sub-surface drainage system located within an open area where the water falls vertically into the connecting chamber. Known also as a 'drop inlet'.
<b>Filter cloth</b>	Industrial grade, non-woven synthetic fabric traditionally used to separate soils and rock of different textures or grain size, but also used as a short-term filter for the removal of medium to coarse sediment from a liquid (usually water).
<b>Gravel</b>	A mixture of coarse mineral particles larger than 2 mm but less than 75 mm in equivalent diameter.
<b>Instream works</b>	Any construction, building or land-disturbing activities conducted between the banks of a constructed drainage channel, watercourse or waterway.
<b>Loam</b>	A medium-textured soil of approximate composition 10 to 25% clay, 25 to 50% silt, and less than 50% sand when dispersed. Such a soil is typically well-graded.
<b>On-grade kerb inlet</b>	Stormwater inlet formed into the kerb of a roadway where the roadway has a positive longitudinal grade (i.e. water approaches the inlet from only one direction).
<b>Proper working order</b>	<p>Means taking all reasonable and practicable measures to sustain all ESC measures in a condition that:</p> <ul style="list-style-type: none"> <li>• will best achieve the site's required environmental protection, including specified water quality objectives for all discharged water (principal objective);</li> <li>• is in accordance with the specified operational standard for each ESC measure, where such a standard is consistent with the site's required environmental protection including specified water quality objectives for all discharged water, or where such a standard is not specified, is consistent with current best practice for each individual ESC measure; and</li> <li>• prevents or minimises safety risks.</li> </ul>
<b>Regulatory authority</b>	Any local or regional external authority—whether government or non-government, including local governments and the state government—that has a legal interest in the regulation or management of either the activity in question, or the land on which the activity is occurring, or is proposed to occur.

<b>Responsible ESC officer</b>	<p>That person, or team of people of which there is a principal officer, employed or contracted by the land owner and/or developer as the principal officer/entity responsible for ensuring appropriate application of the planned ESC measures and for the provision of advice in response to unplanned ESC issues.</p> <p>Terminology will vary from site to site and region to region. May also be referred to as the <i>ESC Officer, Erosion &amp; Sediment Control Officer, Sediment Control Officer, Environmental Officer</i>.</p>
<b>Return (sediment fence)</b>	That part of a sediment fence that is turned up a slope to either prevent water flowing along the fence, or flowing around the end of the fence.
<b>Riparian zone</b>	<p>That part of the landscape adjacent to streams that exert a direct influence on streams or lake margins and on the water and aquatic ecosystems contained within them.</p> <p>Riparian zones include both the stream banks and a variable sized belt of land alongside the banks. Riparian zones have been defined in a legal context in some States as a fixed width along designated rivers and streams.</p>
<b>Sag kerb inlet</b>	Stormwater inlet formed into the kerb of a roadway where the roadway has a zero longitudinal grade (i.e. stormwater approaches the inlet from both directions).
<b>Sand</b>	A soil particulate consisting of particles between 0.02 and 2.0 mm in equivalent diameter when dispersed. Fine sand is defined as particles between 0.02 and 0.2 mm, and coarse sand as those between 0.2 and 2.0 mm.
<b>Sandy soil</b>	A soil that contains at least 50% sand. These are coarse-grained soils that are easy to shovel and break-up when compacted. It is very difficult to form a clod when sandy soils are compressed in the hand.
<b>Sediment</b>	Any clay, silt, sand, gravel, soil, mud, cement, fine-ceramic waste, or combination thereof, transported from its area of origin.
<b>Sediment control measure</b>	Any system, procedure or material used to filter, trap or settle sediment from sediment-laden waters.
<b>Sheet flow</b>	Water flowing at a thin, near-uniform depth that is significantly less than the width of flow.
<b>Shutdown period</b>	<p>Any period during which construction, building and other land-disturbing activities are suspended for an extended period of time (usually greater than three days) prior to the works being continued or completed.</p> <p>Typically during such periods the site is required to be operating in a condition of low erosion risk in accordance with a specified development approval condition or self imposed operating condition.</p>
<b>Silt</b>	Silt is a soil particulate consisting of particles between 0.002 and 0.02 mm in equivalent diameter i.e. intermediate between clay and fine sand sized particles.
<b>Site</b>	The lot or lots of land on which building, construction, or other soil disturbing activities are occurring or proposed to occur.
<b>Table drain</b>	The side drain of a road adjacent to the shoulders, and comprising part of the formation.
<b>TSS</b>	Total suspended solids, usually reported in units of mg/L.
<b>Turbid water</b>	Discoloured water usually resulting from the suspension of fine sediment particles.

<b>Turbidity</b>	A measure of the clarity of water. Commonly measured in terms of Nephelometric Turbidity Units (NTU).
<b>Type 1, Type 2, Type 3 sediment traps</b>	<p>A classification system used to rank sediment control measures based on their ability to trap a specified grain size.</p> <p>Type 1 sediment traps are designed to collect sediment particles less than 0.045 mm in size. These sediment traps include sediment basins and some of the more sophisticated filtration systems used in de-watering operations.</p> <p>Type 2 sediment containment systems are designed to capture sediments down to a particle size of between 0.045 and 0.14 mm. Type 2 sediment traps include rock filter dams, sediment weirs and filter ponds.</p> <p>Type 3 sediment containment systems are primarily designed to trap sediment particles larger than 0.14 mm. These systems include sediment fences, grass buffer zones, and certain stormwater inlet protection systems.</p>
<b>Up-slope</b>	<p>Any location or activity that exists within the higher part of a slope relative to a reference point on the slope.</p> <p>Ordinarily used in reference to overland flow paths or other areas primarily subjected to sheet flow. When referring to drainage lines, channels and watercourses, the term 'upstream' is normally used.</p>
<b>Upstream</b>	<p>Any location or activity that exists within, or moves towards, the higher part of a channel or watercourse relative to a reference point within the channel or watercourse.</p> <p>Ordinarily used in reference to drainage lines, channels and watercourses. When referring to overland flow paths or other areas primarily subjected to sheet flow, the term 'up-slope' is normally used.</p>
<b>USLE</b>	Means: Universal Soil Loss Equation.
<b>Watercourse</b>	Any natural or constructed drainage channel with well-defined bed and banks, including constructed drainage channels of a natural appearance, creeks and rivers.
<b>Waters</b>	Any significant body of water whether natural or constructed, or natural drainage system, including creeks, rivers, ponds, lakes and wetlands.
<b>Waterway</b>	Any natural or constructed drainage line, watercourse with well-defined bed and banks, including creeks and rivers, and any water body including lakes, wetlands, estuaries, bays and oceans.
<b>Work area</b>	The area that will be disturbed by building or construction works, including the area that fully encloses any soil disturbances, the building activities, materials stockpiles and vehicle pathways.
<b>Work site</b>	The area of potential disturbance by building or construction works, or any other soil disturbance that could potentially cause environmental harm, including: any area enclosed by temporary exclusion fencing, the area of ground disturbance and material stockpiles, and the footprint of all new structures and vehicle pathways.

